

## Automated control system for a mashing process

This content has been downloaded from IOPscience. Please scroll down to see the full text.

2015 IOP Conf. Ser.: Mater. Sci. Eng. 93 012059

(<http://iopscience.iop.org/1757-899X/93/1/012059>)

View [the table of contents for this issue](#), or go to the [journal homepage](#) for more

Download details:

IP Address: 31.173.242.138

This content was downloaded on 27/11/2015 at 08:15

Please note that [terms and conditions apply](#).

## Automated control system for a mashing process

**E Teterin<sup>1,a</sup> and V Rudnickiy<sup>1,b</sup>**

<sup>1</sup>Tomsk Polytechnic University, Lenina av. 30, Tomsk, 634050, Russia

E-mail: [badscrool@gmail.com](mailto:badscrool@gmail.com), [rudnickiw@tpu.ru](mailto:rudnickiw@tpu.ru)

**Abstract.** The goal of this paper is to describe a system for a mashing process, which is the first part of brewing beer. The mashing is a procedure where the fermentable (and some non-fermentable) sugars are extracted from malts. The program part based on LabVIEW, which is used to control NI CompactRIO. The main target of the project is to reach a predefined levels of the temperatures and maintain it during the pauses. When the necessary break time is ended the system is ready to go to the new value. The precise control of the temperatures during the breaks is one of the critical factors that define the texture and alcohol content of the beer. The system has two tanks with resistors PT100 in both of them, heat exchanger (coil), heater and pump. The first tank has heating element in order to rise the temperature in the other one. This project has practical solution with all explanations and graphs which are proven working ability of this control system.

### 1. Introduction

Heating is a common process that is used in almost all areas of life. For instance, heating procedure of mash may be used in beer, kvass and other alcohol factories [1]. A lot of serious manufacturers include automation and control of process into their production in order to get competitive advantage. Furthermore, it provides safety, environmentally friendly conditions and reliably for all operations. Consequently, there is an essential to automate heating processes. To supply this need, nowadays exists various types of intellectual appliance and software for them. The project includes the ways and set of devices to solve the problem in the automation. In order to design and construct effective control system, it is necessary to find out what and how all components are going to control system functions. So, the system has sensors, controller (CompactRIO), and final control elements (controlled device) [2].

As efficient controller in this project was chosen CompactRIO which was made by National Instruments company by way of one of the best variant to find solution. It is worked with NI LabVIEW which has reconfigurable I/O (RIO) architecture and includes a lot of different functions that were made primarily for technical measuring and program applications. This controller introduces an embedded real-time manufactured device which is representing the possibility to fast program, change and actuate CompactRIO with easy-to-use graphical instruments. This represents security and productivity for any applications and controller may be remotely managed with Ethernet. However, CompactRIO is not so flexible because it must be programmed only with LabVIEW. On the other hand, LabVIEW is strong graphical language that is introducing the flexible and the fast method to create a program. Software which was mentioned above is perfect for different kind of measurements. It is able to help programmer to focus on the difficult tasks and create invisible for user graphical complexity [3].



## 2. The system functions

The system has the pump to manage the temperature in the tank which has not the heat exchanger and to deliver mash to the second one container when the temperature does not reach the predefined level. The voltage for the pump is 12 VDC and can be controlled with PWM. The second tank has heat exchanger. Wort is pumped through the heat exchanger. For some reason, it seems that such system is irrational, but due this fact that mash is isolated from the water it makes the project is logical because often some technological process requires solution like this. The system has two resistance thermometers (PT100) to control the temperature which were installed in both containers. They are sensors to measure a level of temperature by correlating the temperature with the resistance of an element of sensor. The element has a length coiled wire wrapped around a platinum core. The heating resistor (230V AC, ca. 2 kW) in the heating water container is controlled with a relay. Simplified scheme of the control system is pictured in the figure 1. It is not precise prototype, but there is shown basic principles and it has all essential moments in order to understand automated mashing process control.

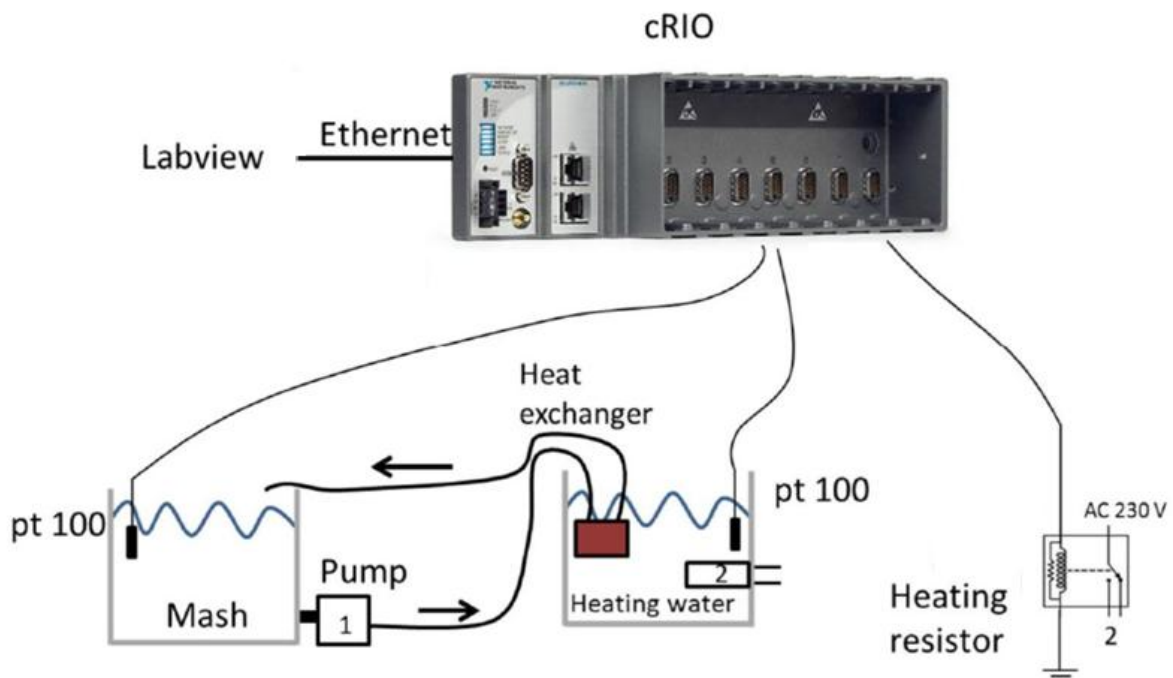

**Figure 1.** The basic features of control heating system.

The control system has the following functionalities:

1. The heating resistance resistor is controlled with LabVIEW and through the fixed time the program plot the graphs of the temperatures from tanks. The application may open and read any required temperatures and break times profile from a text file (txt, doc and so on);
2. Pump is programmed using VHDL (Very high speed integrated circuits language) and the operation is based on PWM (pulse-width modulation);
3. The system has opportunity for emergency stop;
4. The temperature of water must not be higher than the limit in the temperature profile;
5. The system is automated. Means that it has possibility for a little participation of human;
6. The application is able to print out the temperature through some intervals into a log file.

## 3. LabVIEW programming

The majority piece of system functionality is based on LabVIEW programming. As the first step to solve the problem, there was created correlation between Celsius degree and electrical resistance. By using equation of Callendar- Van Dusen the program can converse the resistance to temperature, as in equation (1).

$$R_t = R_0(1 + At + Bt^2) \tag{1}$$

where  $R_t$  is the resistance at temperature  $t$ ,  $A = 3.9 \cdot 10^{-3} \text{ } ^\circ\text{C}^{-1}$  and  $B = -5.8 \cdot 10^{-7} \text{ } ^\circ\text{C}^{-2}$ .

Realization the general part of the system requires the method of state machine, which has 7 states. This method is a technique which is using in programming in a lot of different languages. It is essential and flexible instrument because a coding becomes more efficient, simple and understandable [4]. The application consists from the next states:

1. «Read Array». The stage was made to load temperature profile and set starting value. Moreover, this state begins to indicate all parameters. In order to save time and resources, as soon as program was started, the state has been already turned on pump and heater (figure 2).

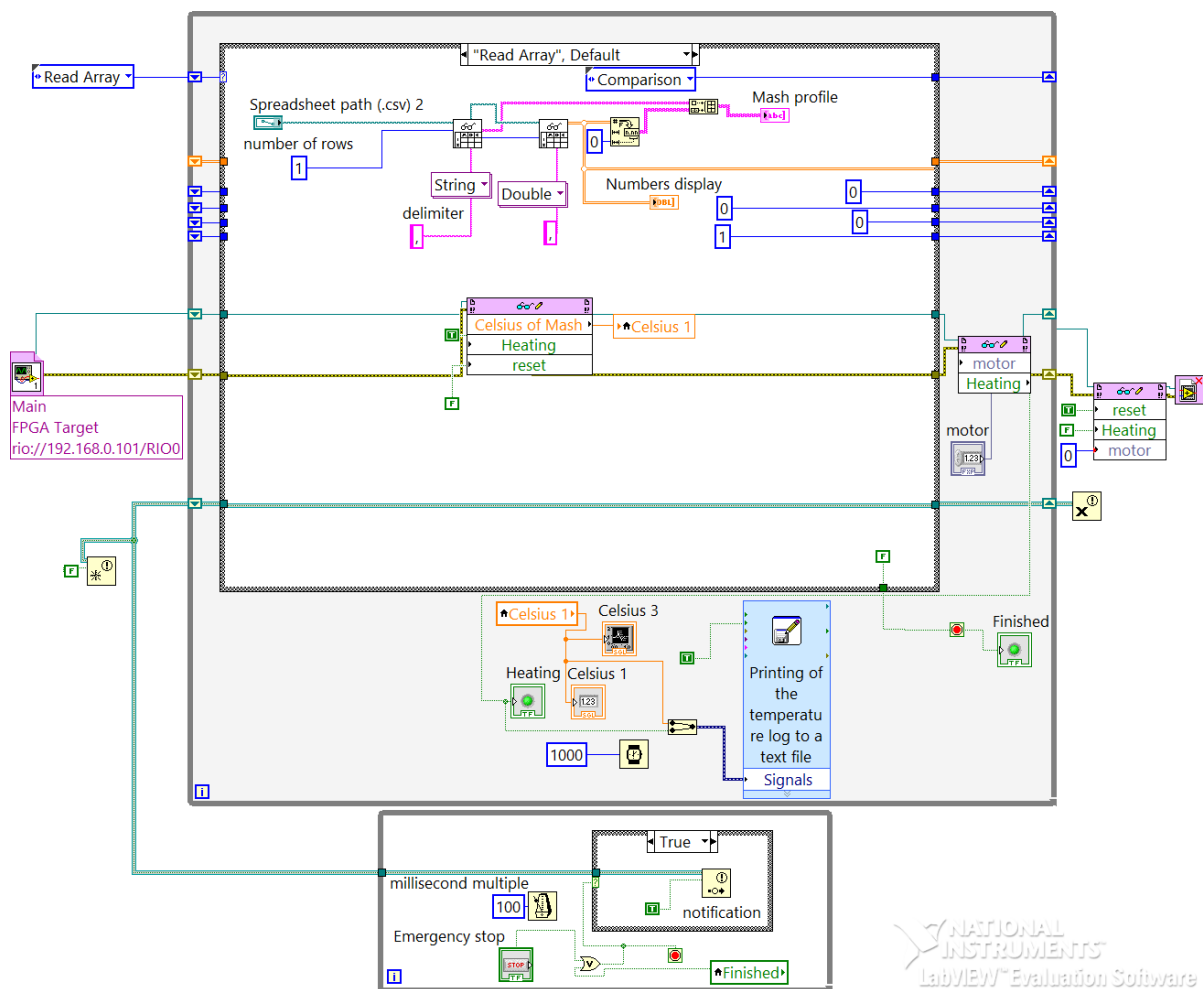

**Figure 2.** Realization of state machine in LabVIEW.

2. «Comparison». On this state ideal temperature which was getting from the profile compare with actual temperature from container. After that the program is going to start indicate pause time and ideal temperature value to manage the control system better.

3. «Start heating and pumping». The main idea of this stage that if the ideal temperature is higher than real temperature (condition from the previous state is true) than the program is going to leave the pump and heater is turned on and go to the previous state. Otherwise the program will go to the next stage.

4. «Stop heating». As was said above, the system will go to the next state in case if the condition from the «Comparison» state is false. It means application will turn off the heater, however the pump will stay turned on in order to supply the temperature level.

5. «Start timer». The state is responsible for the break time. This is the most important stage because all technological processes depend on how accurately the temperature is maintained. This state has complex structure because inside of it the program includes while loop in order to support the temperature during the pause time. The most complicated moment is connected with stopping loop during the pause time because there is two parallel loops which should work simultaneously. Furthermore, here exists an indicator which is able to show how much time left. Because of necessity of controlling pump and indicators inside of while loop, a problem with indicators and pump can be solved with «local variable».

6. «Increase the index». This case is made to check actual value of temperature and go to the next value from the temperature profile if it is necessary. The program will comparing the number of rows which were multiplied by 2 with sum of the previous index which increased by 1.

7. «Finished». This is the last stage of the program if the application stops without emergency case. On this state will turn off pump, heater and clear all indexes. However, in case of emergency stop the program after all operations will return on the state that is why this stage is so important.

LabVIEW introduces special block which is called «Write to a measurement file» to realize printing out data into a text file. Moreover, using an operator «Stop control», which is connected with Boolean operator «Or», there is opening opportunity to create the possibility for emergency stop. Due to this combination the program can stop either in common way or in emergency stop if it is necessary. To stop both parallel loops there was used block «Notification». It provides the real time control for the procedure in all operations included the pause times [5]. An interface of the applications is show in the figure 3.

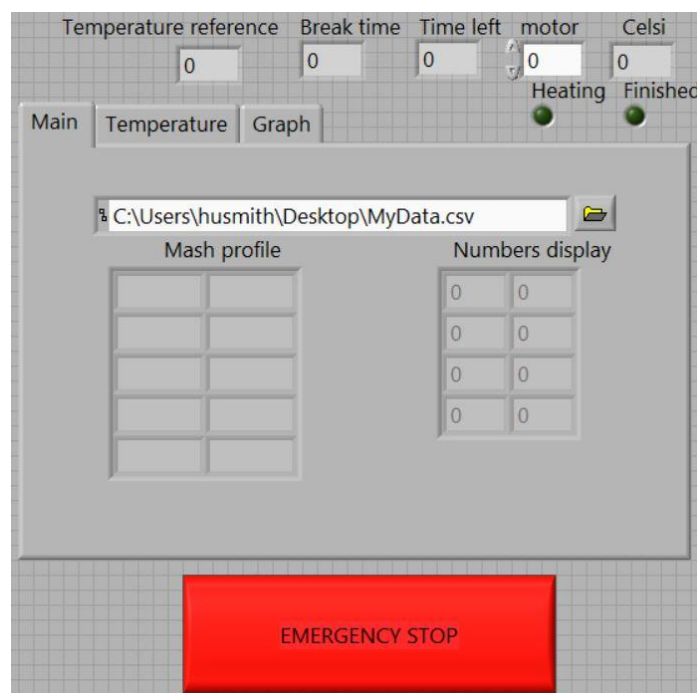

**Figure 3.** Interface of the program.

#### 4. Operation of the pump

The pump is based on PWM technology. It is programmed with VHDL and after that this code was integrated into LabVIEW by using special functions «IP-block» and «Read/Write Control» in the FPGA (part of coding in LabVIEW). The general idea of VHDL code is only to control PWM value of the pump's motor. It has three inputs; «mclk», «reset» and «motor». «Mclk» means clock signal, and «reset» is reset signal. «Motor» is vector (7 down to 0) which is put manually. It decides the maximum constant of counter as 255. If «reset» signal is activated, output value pump directly goes to 0. If it is not, there are two stages; «update» and «pwm». In «update» stage, it gets the duty cycle from the input value «motor» and move to «pwm» stage. In «pwm» stage, the counter increases by 1 for every rising edge of clock and if it reaches the value of motor, the output value «pump» turn on to 1 unless the value of pump is 0. When counter reaches 255 (maximum constant), initialize count value and go to «update» stage again. The figure 4 represents the simulation of the pump in VHDL.

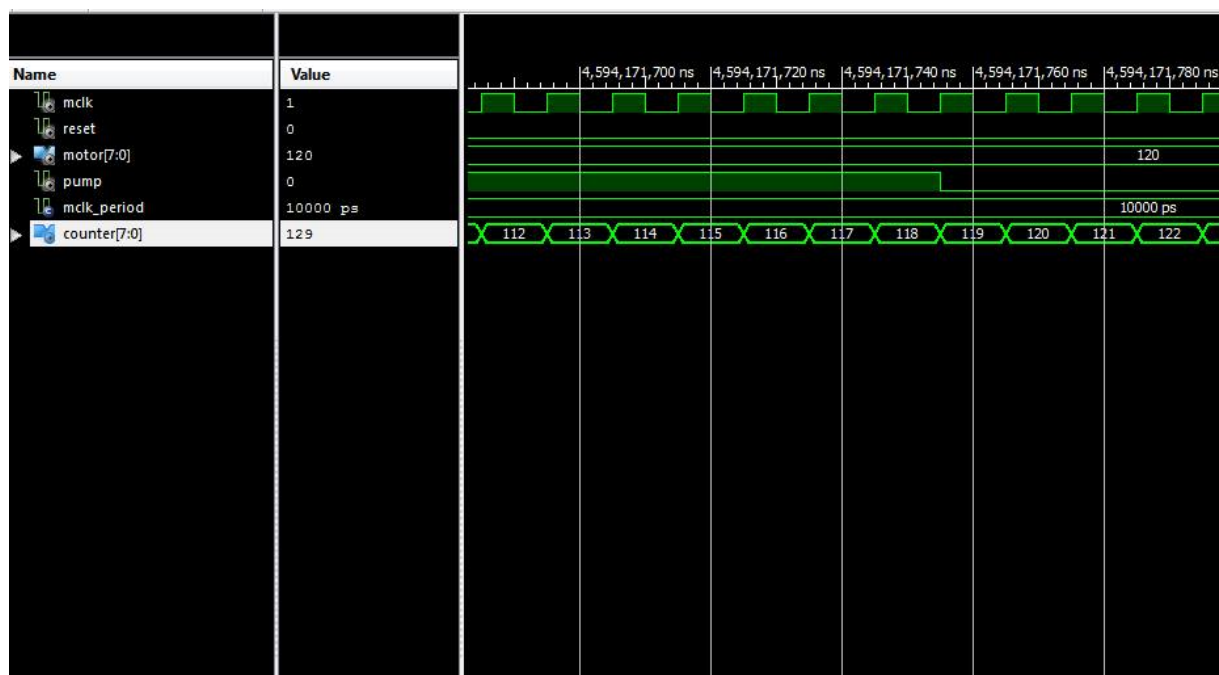

Figure 4. Operation of the pump.

#### 5. Conclusion

The project is represented the working solution of control the mashing process. Practical tests of the system in the laboratory was proven the program is working in the right way. LabVIEW and CompactRIO are one of the best way to solve the problems like this. All results, which was reached and explained in this paper, can be useful in a lot of branches of production. Implementation of such tasks required knowledge in a number of technologies including: electrical systems, instrumentation, real time data acquisition, process modeling, control structure development, and controller tuning.

#### 6. References

- [1] Malyshenko A M and Semyonov N M 1999 Using of indexes of fundamental characteristics of controllable objects for raising resistance to failure of automatic control system *The 3th Russia-Korean Int. Symp. on Science and Technology*. **1** 5
- [2] Bitter R, Mohiuddin T and Nawrocki M 2007 *LabVIEW: Advanced Programming Techniques* (Boca Raton: CRC Press) p 163
- [3] Sharma K 2011 *Overview of Industrial Process Automation* (Waltham: Elsevier) p 210

- [4] Marlin T 1995 *Process Control: Designing Processes and Control Systems for Dynamic Performance* (New York: McGraw-Hill) p 453
- [4] Malyshenko A M 1997 Automatic control systems with redundant dimension of a vector of control: theoretical and applied aspects *The 1st Korea-Russia Symposium on Science and Technology*. **1** 49
- [5] Kachin O S 2007 *Diagnosing the mechanical state of the collector-brush unit of the high-speed electric machine at resource tests* (Tomsk University Publishing) pp 112-116