

Tomsk Polytechnic University

Antonov V. M., Pichugin V. F., Pivovarov Yu. L.

PHYSICS II
Textbook

**Electricity and Magnetism. Electromagnetic Oscillations and
Waves**

Tomsk 2002

UDC 53 (076)

Antonov V. M., Pichugin V. F., Pivovarov Yu. L. PHYSICS II. Electricity and Magnetism. Electromagnetic Oscillations and Waves. Textbook. Tomsk: TPU, 2002, 93 pp.

This textbook is the second part of the general course in physics for technical universities. It includes Electricity and Magnetism, Oscillations and Waves. The main theoretical concepts are formulated in logical fashion. There are many examples and practice problems to be solved. This textbook has been approved by the Department of Theoretical and Experimental Physics and the Department of General Physics of TPU.

Reviewed by: V.Ya. Epp, Professor of Department Physics and Mathematics, TSPU, D.Sc.

Preface	3
1. 1 Electric Field in a Vacuum	2
1.1 Electric charge	2
1.2 Coulomb's law	3
1.3 Electric Field Strength	3
1.4 Gauss' Theorem	4
1.5 Calculating fields with the aid of Gauss' theorem	5
1.6 Potential	7
1.7 Relations between the electric field strength and potential	8
1.8 Equipotential Surfaces and Strength Lines	9
1.9 Capacitance	10
1.10 Interaction Energy of a System of Charges	12
1.11 Energy of a Charged Conductor	12
1.12 Energy of a Charged Capacitor	12
1.13 Examples	13
2. Electric Field in Dielectrics	21
2.1. Dipole Electric Moment	21
2.2. Polar and Non-polar Molecules	22
2.3 Polarization of Dielectrics	22
2.4 Space and Surface Bound Charges	23
25 Electric Displacement Vector	25
2.6 Examples of Calculating the Field in Dielectrics	26
2.7 Conditions at the Interface Between Two Dielectrics	29
2.8 Forces Acting on a Charge in a Dielectric	31
Examples	32
3. Steady Electric Current	37
3.1. Electric Current	37
3.2. Continuity Equation	38
3.3 Electromotive Force	39
3.4. Ohm's Law. Resistance of Conductors	40
3.5. Ohm's Law for an Inhomogeneous Circuit Section	41
3.6 Kirchhoff's Rules	42
3.7 Power of a Current	43
3.8 The Joule-Lenz Law	43
Examples	44
4. 4. Magnetic Field	46
4.1. Biot-Savart's law. Ampere's law	46
4.2 The Flux and Circulation of Magnetic Field	34
4.3 Lorentz's force. Hall's effect	58
4.4 Electromagnetic induction	63

Problems to Chapter 4 (Magnetic field)	65
5. Magnetic field in matter	66
5.1 Magnetic moments of atoms	66
5.2 Magnetic properties of matter	69
5.3 Classification of Magnetic Materials (Substances)	70
6. Maxwell's Equations	.72
6.1 Maxwell's Equations in an Integral Form	72
6.2 . Maxwell's Equations in the Differential Form	75
7. Electromagnetic oscillations and waves	77
7.1. Electromagnetic oscillations	77
7.2 7.2. Electromagnetic Waves	83

PREFACE

This textbook is a second part of course in introductory physics for students mastering science or engineering. The main objective of this part is electromagnetism, which involves the theory of electricity, magnetism, and electromagnetic fields.

The mathematical background of the student taking this course should include one or two semesters of calculus. A large number of examples of varying difficulty are presented as an aid in understanding concepts. In many cases, these examples serve as models for solving another problems.

Electricity and Magnetism

2. Electric Field in a Vacuum

2.1 Electric charge

Electrostatics is a science dealing with the interaction of electric charges at rest. The motion at velocities $v \ll c$ may also be taken into consideration.

In nature there are two kinds of electric charges: positive and negative. These definitions have been established historically. In our “common” world, the electric charge of a body is caused either by excess or deficiency of electrons or protons – the main particles of which atoms are composed, (the third fundamental particle – neutron has no electric charge). The electron carries the negative charge $-e$, the proton carries the positive charge $+e$. SI unit of $e = 1.6 \cdot 10^{-19}$ Coulomb. One coulomb is a charge, passing through the conductor’s cross-section during the unit time (1 sec) when the current strength equals 1A.

Electrons, protons and neutrons are the “bricks” of which the atoms and molecules of any substance are built, therefore all bodies contain electric charges. The charge q of a body is formed by a plurality of elementary charges, i.e.

$$q = \pm Ne \tag{1.1}$$

An elementary charge is so small that macroscopic charges may be considered to have continuously changing magnitudes.

The magnitude of a charge in different inertial frames is known to be the same; thus, an electric charge is a relativistic invariant.

Electric charges can vanish and appear again. Two elementary charges of opposite signs always appear or vanish simultaneously. For example, an electron and positron meeting each other annihilate themselves giving birth to two or more gamma-photons: $e^- + e^+ \rightarrow 2\gamma$. And vice versa, a gamma-photon getting into the field of an atomic nucleus transforms into a pair of particles (an electron and a positron), i.e.: $\gamma \rightarrow e^- + e^+$.

Thus, the total charge of an electrically isolated system (no charged particles can penetrate through the surface confining it) does not change. This statement forms the **law of electric charge conservation**. It must be noted that the law is associated with the relativistic invariance of a charge. Indeed, if the magnitude of a charge depended on its velocity, then by bringing charges of one sign into motion we would change the total charge of the relevant isolated system.

2.2 Coulomb's law

The law describing the interaction between point charges was established experimentally in 1785 by Charles A. De Coulomb. A *point charge* is defined as a charged body whose dimensions may be disregarded in comparison with the distances from this body to other bodies carrying electric charges. Coulomb's law can be formulated as follows: the force of interaction between two stationary point charges is proportional to the magnitude of each of them and inversely proportional to the square of the distance between them; the direction of the force coincides with that of straight line (see Figure 1.1), connecting the charges.

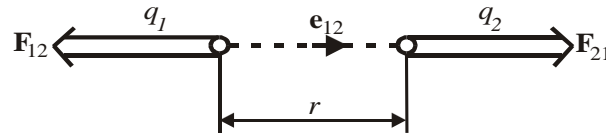

Figure 1.1

Coulomb's law can be expressed by the formula

$$\mathbf{F}_{12} = -k \frac{q_1 \cdot q_2}{r^2} \mathbf{e}_{12} \quad (1.2)$$

Here k is the proportionality constant which is positive, q_1 and q_2 is the magnitudes of the interacting charges, r is the distance between the charges, \mathbf{e}_{12} is the unit vector directed from the charge q_1 to q_2 , \mathbf{F}_{12} is the force acting on the charge q_1 (Figure 1.1 corresponds to the case of like charges).

The force \mathbf{F}_{21} differs from \mathbf{F}_{12} in its sign. Experiments show that the force of interaction between two charges does not change if other charges are placed near them. Assume that we have the charge q and, in addition N other charges q_1, q_2, \dots, q_N . Then, the resultant force \mathbf{F} with which N charges q_i act on the charge q can be expressed by

$$\mathbf{F} = \sum_{i=1}^N \mathbf{F}_i, \quad (1.3)$$

where \mathbf{F}_i is the force with which the charge q_i acts on the charge q in the absence of the other $N-1$ charges. The formula (1.3) is the sequence of the field superposition principles.

Experimental facts show that Coulomb's law holds for distances from 10^{-15} m up to, at least, several kilometers. In terms of the SI-units, the formula (1.2) can be written

$$\text{as } \mathbf{F}_{12} = -\frac{1}{4\pi\epsilon_0} \cdot \frac{q_1 \cdot q_2}{r^2} \cdot \mathbf{e}_{12} \quad (1.4)$$

The quantity ϵ_0 is called the *electric constant*, $\epsilon_0 = 8.85 \cdot 10^{-12}$ F/m.

2.3 Electric Field Strength

To describe and characterize the properties of space surrounding an electric charge the notion of *electric field* was introduced. An electrostatic field is characterized by the quantity \mathbf{E} called the *electric field strength*. The force \mathbf{F} acting upon an electric charge q located in an electrostatic field is

$$\mathbf{F} = q\mathbf{E} \quad (1.5)$$

Comparing (1.5) and (1.4) we come to a conclusion that the electric field strength produced by a point charge q at a distance r is equal (absolute magnitude) to

$$E = -\frac{q}{4\pi\epsilon_0 r^2} \quad (1.6)$$

In the vector form, Equation (1.6) can be expressed by

$$\mathbf{E} = -\frac{q\mathbf{e}_r}{4\pi\epsilon_0 r^2} \quad (\text{see Figure 1.2}) \quad (1.7)$$

We have already mentioned that the force with which a system of charges acts on a charge not belonging to the system equals the vector sum of the forces which each of the charges of the system exerts separately on the given charge (see Equation 1.3). Hence, it follows that the field strength of a system of charges equals the vector sum of the field strengths that would be produced by each of the charges of the system

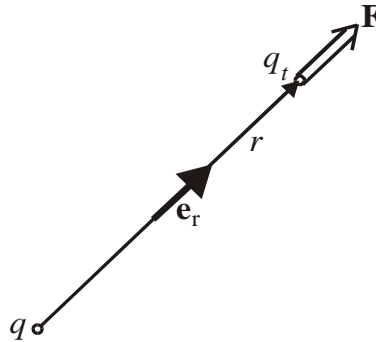

Figure 1.2 (q is positive)

separately:

$$\mathbf{E} = \sum \mathbf{E}_i \quad (1.8)$$

This statement is called the *principle of electric field superposition*.

2.4 Gauss' Theorem

The flux of an electric field strength vector through a closed surface equals the algebraic sum of the charges enclosed by this surface divided by ϵ_0 , i.e.

$$\oint \mathbf{E} \cdot \mathbf{d}s = \frac{1}{\epsilon_0} \sum_{(i)} q_i \quad (1.9)$$

This statement is known as *Gauss' theorem*.

When considering fields set up by macroscopic charges (i.e. charges formed by an enormous number of elementary charges), it is conventional to describe their distribution in space continuously, with a finite density. *The volume density of a charge* ρ is determined as the ratio of the charge dq to the infinitely small (physically) volume dV containing this charge:

$$\rho = \frac{dq}{dV} \quad (1.10)$$

An *infinitely small (physically) volume* is the volume which on the one hand is sufficiently small for the density within its limits to be considered identical, and on the other hand is sufficiently great for the discreteness of the charge not manifest itself.

Thus, replacing the surface integral in Equation (1.9) with a volume one in accordance with Stokes' theorem, we have

$$\int_V \nabla E \cdot dV = \frac{1}{\epsilon_0} \int_V \rho dV \quad (1.11)$$

This relation holds for any arbitrary chosen volume V . Hence,

$$\nabla E = \frac{1}{\epsilon_0} \rho \quad (1.12)$$

Equation (1.12) expresses Gauss' theorem in the differential form.

2.5 Calculating fields with the aid of Gauss' theorem

Using Gauss' theorem it is rather easy to calculate the electric field strength produced by the charged bodies with some kind of symmetry.

2.5.1 Field of an uniformly charged ball

As an example, let us calculate the electric field strength inside and outside of a uniformly charged ball.

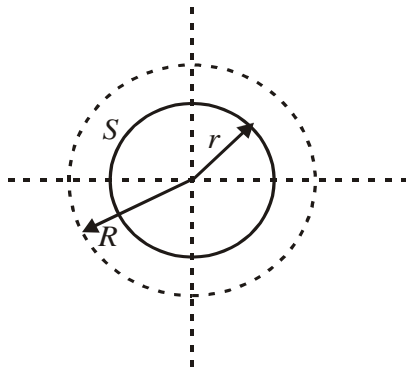

Figure 1.3. (radius R , volume charge density ρ is positive)

It is quite obvious that the electric field at every point is directed along the radius vector (the electric field has a spherical symmetry). A glance at the Figure 1.3 shows that for every arbitrary spherical surface S inside the ball, we can write Gauss'

theorem as follows:

$$\int E dS = \frac{1}{\epsilon_0} \frac{4}{3} \pi r^3 \cdot \rho$$

(directions of \mathbf{E} and $d\mathbf{s}$ coincide), or $E \cdot 4\pi r^2 = \frac{1}{\epsilon_0} \frac{4}{3} \pi r^3 \rho$ which leads to

$$E = \frac{1}{3\epsilon_0} \cdot \rho \cdot r \quad (1.13)$$

or taking into consideration that $\rho = \frac{q}{4/3\pi R^3}$ (q is the total charge of the ball), we have

$$E = \frac{q \cdot r}{4\pi\epsilon_0 R^3}, \quad r < R \quad (1.14)$$

For the distance $r > R$,

$$E = \frac{q}{4\pi\epsilon_0 r^2} \quad (1.15)$$

The result is shown in Figure 1.4 (We recommend our readers to make the necessary calculations).

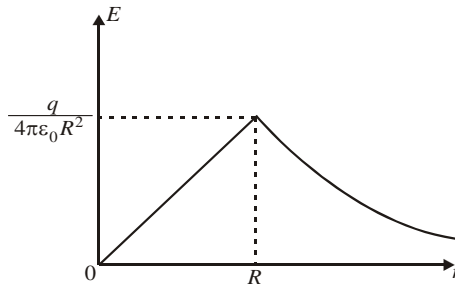

Figure 1.4. Electric field strength produced by the uniformly charged ball

2.5.2 Field of an Infinite, Homogeneously Charged Plane

If a charge is concentrated in a thin surface layer of the body carrying the charge, a quantity called the *surface density* σ is usually used.

$$\sigma = \frac{dq}{dS} \tag{1.16}$$

Here, dq is the charge contained in the layer of area dS .

Assume that the surface charge density at all points of a plane (see Figure 1.5) is identical and equal to σ . Let us imagine a cylindrical surface with generatrices perpendicular to the plane and bases S arranged symmetrically relative to the plane, see Figure 1.5.

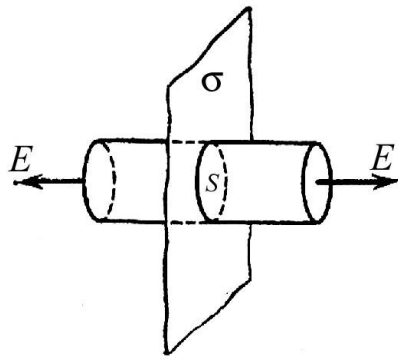

Figure 1.5.

It follows from the consideration of symmetry that the field strength at any point is directed at right angles to the plane. Indeed, since the plane is infinite and homogeneously charged, there is no reason why the vector \mathbf{E} should deflect to a side from a normal to the plane. It is further evident that at points symmetrical relative to the plane, the field strength is identical in magnitude and opposite in direction. Thus, we can write

$$2E \cdot S = \frac{\sigma S}{\epsilon_0} \tag{1.17}$$

Whence,

$$E = \frac{\sigma}{2\epsilon_0} \tag{1.18}$$

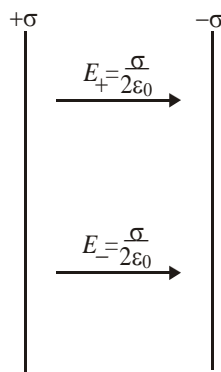

Figure 1.6

The result does not depend on the length of the cylinder. So, the magnitude of the field strength is the same at any point. The field strength within two parallel infinite planes (see Figure 1.6) carrying opposite charges with a constant surface density σ identical in magnitude can be found by superposition of the fields produced by each plane separately.

Obviously, inside the planes $E = E_+ + E_-$.

$$E = \frac{\sigma}{\epsilon_0} \tag{1.19}$$

Outside the planes E equals zero.

2.6 Potential

Let us consider the field produced by a stationary point charge q (see Figure 1.7). At any place of this field, the point charge q' experiences the force

$$\mathbf{F} = \frac{1}{4\pi\epsilon_0} \frac{q \cdot q'}{r^2} \mathbf{e}_r = F(\mathbf{r})\mathbf{e}_r \quad (1.20)$$

Here, $F(\mathbf{r})$ is the magnitude of a force, and \mathbf{e}_r is the unit vector. The force (1.20) is a central one. A central force field is known to be conservative. Hence, the work done by the field on the charge q' when it moves from one point to another does not depend on the path. This work can be written as follows:

$$A_{12} = \int_1^2 F(r) \cdot \mathbf{e}_r \cdot d\mathbf{l} \quad (1.21)$$

Here, $d\mathbf{l}$ is the elementary displacement of the charge q' . The scalar product $\mathbf{e}_r \cdot d\mathbf{l}$ equals the increment dr of the magnitude of the position vector \mathbf{r} .

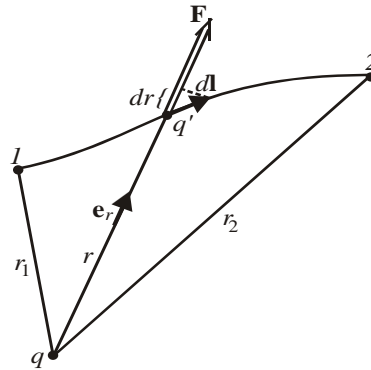

Figure 1.7

The equation (1.21) can be written in the form:

$$A_{12} = \int_1^2 F(r) dr \quad (1.22)$$

Calculating the integral we have

$$A_{12} = \frac{1}{4\pi\epsilon_0} \left(\frac{qq'}{r_1} - \frac{qq'}{r_2} \right) \quad (1.23)$$

The work done by the conservative force is known to be expressed as a decrement of the potential energy:

$$A_{12} = W_1 - W_2 \quad (1.24)$$

A comparison of Equations (1.23) and (1.24) leads to the following expression for the potential energy of the charge q' in the field of the charge q :

$$W = \frac{1}{4\pi\epsilon_0} \cdot \frac{qq'}{r} + \text{const} \quad (1.25)$$

Obviously, when $r \rightarrow \infty$, $W \rightarrow 0$, we get

$$W = \frac{1}{4\pi\epsilon_0} \cdot \frac{qq'}{r} \quad (1.26)$$

The quantity $\varphi = W/q'$ is called the **field potential** at a given point, and it is used together with the field strength \mathbf{E} to describe electric field. So, the potential produced by a point charge q at a distance r is

$$\varphi = \frac{1}{4\pi\epsilon_0} \cdot \frac{q}{r} \quad (1.27)$$

Using the superposition principle we get:

$$\varphi = \frac{1}{4\pi\epsilon_0} \cdot \sum_{i=1}^N \frac{q_i}{r_i} \quad (1.28)$$

The equation (1.28) signifies that the potential of the field produced by a system of charges equals the algebraic sum of the potentials produced by each of the charges separately. Whereas, the field strengths are added vectorially in the superposition of fields, the potentials are added algebraically. This is why it is usually more convenient to calculate the potentials than the electric field strengths. The work of the field forces on the charge q can be expressed as follows:

$$A_{12} = q(\varphi_1 - \varphi_2) \quad (1.29)$$

If the charge q is removed from a point having the potential φ to infinity, then

$$A_\infty = q\varphi \quad (1.30)$$

Hence, the potential numerically equals the work done by the forces of a field on a unit positive point charge when the latter is removed from the given point to infinity. Work of the same magnitude must be done against the electric field forces to move a unit positive point of a field. Equation (1.30) can be used to establish the units of potential. The SI unit of potential called the **volt** (V) is taken equal to the potential at a point when work of 1 joule has to be done to move a charge of 1 coulomb from infinity to this point $1\text{J} = 1\text{C}\cdot 1\text{V}$. Whence,

$$1\text{V} = \frac{1\text{J}}{1\text{C}} \quad (1.31)$$

2.7 Relations between the electric field strength and potential

This relation can be easily established using the relevant relation between the force and potential energy of conservative fields.

$$\mathbf{F} = -\text{grad } W = -\nabla W \quad (1.32)$$

For a charged particle in an electrostatic field, we have $\mathbf{F}=q\mathbf{E}$ and $W=q\varphi$. Introducing these values into equation (1.32), we find that

$$\mathbf{E} = -\text{grad } \varphi = -\nabla\varphi \quad (1.33)$$

when an electric charge moves along the closed path, the work done is zero

$$A = q \oint_{\Gamma} \mathbf{E} \cdot d\mathbf{l} = 0 \quad (1.34)$$

The quantity $\oint_{\Gamma} \mathbf{E} d\mathbf{l}$ is called the circulation of an electrostatic field.

$$\oint_{\Gamma} \mathbf{E} d\mathbf{l} = 0 \quad (1.35)$$

Let us take an arbitrary surface S resting on contour Γ (see Figure 1.8).

According to Stokes' theorem, the integral of curl \mathbf{E} taken over this surface equals the circulation of the vector \mathbf{E} around contour Γ :

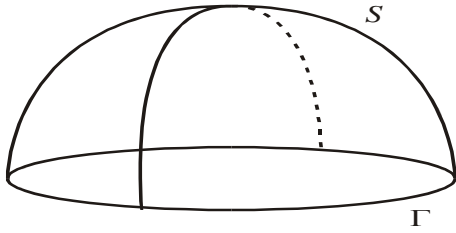

Figure 1.8

$$\int_S [\nabla E] dS = \oint_{\Gamma} \mathbf{E} d\mathbf{l} \quad (1.37)$$

Since the circulation equals zero, then

$$\int_S [\nabla E] dS = 0 \quad (1.38)$$

This condition holds for any surface S rested on arbitrary contour Γ . This is possible only if the curl of the vector \mathbf{E} at every point of the electrostatic field

equals zero:

$$[\nabla E] = 0 \quad (1.39)$$

2.8 Equipotential Surfaces and Strength Lines

Graphically an electrostatic field can be characterized by the equipotential surfaces and strength lines. An imaginary surface all of whose points have the same potential is called the *equipotential surface*. Its equation has the form:

$$\varphi(x, y, z) = \text{const} \quad (1.40)$$

The *strength lines* are imaginary lines drawn in such a way that a tangent to them at every point coincides with the direction of vector \mathbf{E} . The density of the lines is selected so that their number passing through a unit area at right angles to the lines, equals the numerical value of vector \mathbf{E} . Thus, the potential does not change in movement along an equipotential surface over the distance dl ($d\varphi = 0$). Hence, the tangential component of vector \mathbf{E} equals zero:

$$E_t = -\frac{\partial \varphi}{\partial l} = 0 \quad (1.41)$$

The vector \mathbf{E} at every point is directed along a normal to the equipotential surface passing through the given point. Thus, we can conclude that the field lines at every

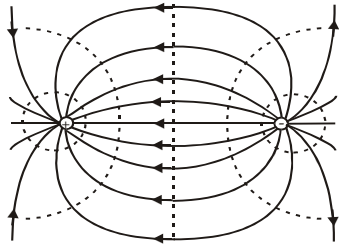

Figure 1.9

point are orthogonal to the equipotential surfaces. As an example, in Figure 1.9 the equipotential surfaces and strength lines of a dipole are shown.

When an uncharged conductor is placed into an electrostatic field, its electric charges begin to move till the state of equilibrium is established. The positive charges are displaced in the direction of the external field, the negative – in the opposite direction. As a result, charges of opposite signs called the *induced charges* appear at the ends of the conductor (see Figure 1.10).

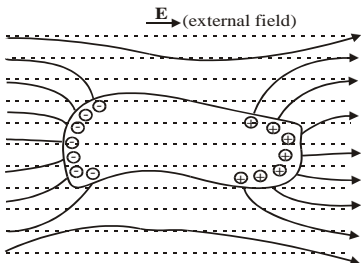

Figure 1.10

The charge carriers will be redistributed until the resultant field inside the conductor equals zero, i.e. the strength of the field inside the conductor vanishes and the field lines outside the conductor are perpendicular to its surface (obviously, the conductor's surface is an equipotential one). Thus, a neutral conductor placed into an electric field disrupts part of the field lines – they terminate on the negative induced charges and begin again on the positive one.

1.9. Capacitance

If a conductor is isolated, i.e. the other bodies are very far from it, then the experiments show that the charge and potential of the conductor are proportional one another.

$$q = C\varphi \quad (1.42)$$

A quantity

$$C = \frac{q}{\varphi} \quad (1.43)$$

is called the *capacitance*. In accordance with Equation (1.43), it follows that the capacitance numerically equals the charge which when imparted to a conductor increases its potential by unity (1V). SI-unit of capacitance is a *farad* (F). The farad is a very big unit. Indeed, an isolated sphere having a radius of $9 \cdot 10^9$ m, i.e. a radius 1500 times greater than that of the Earth, would have the capacitance of 1 F. For this reason, submultiples of farad are used in practice – the millifarad (mF), microfarad (μ F), nanofarad (nF), and picofarad (pF).

Isolated conductors have a small capacitance. However, such devices are needed in practice which with a low potential relative to the surrounding bodies would accumulate charges of an appreciable magnitude. Such devices, called *capacitors*, are based on the fact that the capacitance of a conductor increases when other bodies are brought close to it. This in its turn is due to the fact that induced charges of the sign opposite to that of the conductor will be closer to the conductor than charges of the same sign, thus diminishing the conductor's potential and in accordance with equation (1.43) increasing its capacitance. Capacitors are made in the form of two conductors placed close to each other. The conductors forming a capacitor are called its *plates*, which can be made in the form of two plates, two coaxial cylinders, and two concentric spheres. Accordingly, they are called *parallel-plate*, *cylindrical*, and *spherical capacitors*. The electrostatic field is confined inside a capacitor. The strength (in general case, the electric displacement (see section 2)) lines begin on one plate and finish on the other. Consequently, the charges produced on the plates have the same magnitude and are opposite in sign.

The basic characteristic of a capacitor is its *capacitance*, by which is meant a quantity proportional to the charge q and inversely proportional to the potential difference between the plates:

$$C = \frac{q}{\varphi_1 - \varphi_2} \quad (1.44)$$

The potential difference $\varphi_1 - \varphi_2$ is called the *voltage* across the relevant plates. We shall use the symbol U to designate the voltage. Hence, equation (1.44) can be written as follows:

$$C = \frac{q}{U}$$

The magnitude of capacitance is determined by the geometry of the capacitor (the shape and dimensions of plates and their separation distance), and also by the dielectric properties of the medium between the plates, which is characterized by the permittivity (ε) (see section 2).

The capacitance of a parallel-plate capacitor is

$$C = \frac{\varepsilon_0 \varepsilon S}{d} \quad (1.45)$$

where S is the area of a plate, d is the separation distance of the plates. For example the capacitance of a cylindrical capacitor

$$C = \frac{2\pi\varepsilon_0\varepsilon l}{\ln(R_2/R_1)} \quad (1.46)$$

where l is the length of the capacitor, R_1 and R_2 are the radii of the internal and external plates. The capacitance of a spherical capacitor is

$$C = 4\pi\varepsilon_0\varepsilon \frac{R_1 R_2}{R_2 - R_1} \quad (1.47)$$

where R_1 and R_2 are the radii of the internal and external plates.

Capacitors can be connected in parallel; in this case the voltage across the both capacitors is the same, so: $q_1 = C_1 U$, $q_2 = C_2 U$, or $q = q_1 + q_2 = (C_1 + C_2)U = CU$, hence

$$C = C_1 + C_2 \quad (1.48)$$

For some capacitors:

$$C = \sum C_i \quad (1.49)$$

When two capacitors are connected in series, then the magnitude of charges on the plates is the same, so: $U_1 = \frac{q}{C_1}$; $U_2 = \frac{q}{C_2}$;

$U = U_1 + U_2 = (\frac{1}{C_1} + \frac{1}{C_2})q = \frac{q}{C}$, hence

$$\frac{1}{C} = \frac{1}{C_1} + \frac{1}{C_2} \quad (1.50)$$

For several capacitors:

$$\frac{1}{C} = \sum \frac{1}{C_i} \quad (1.51)$$

1.10 Interaction Energy of a System of Charges

In accordance with equation (1.19), the interaction energy of a system of charged particles can be written in the form:

$$W = \frac{1}{2} \sum_{(i \neq k)} \frac{1}{4\pi\epsilon_0} \frac{q_i q_k}{r_{ik}}, \quad (1.52)$$

where r_{ik} is the distance between the q_i and q_k charges. The factor “1/2” is necessary in order not to take into account the W_{ik} two times. Equation (1.52) can be rewritten as follows:

$$W = \frac{1}{2} \sum_{(i)} q_i \sum_{k=1} \frac{1}{4\pi\epsilon_0} \frac{q_k}{r_{ik}} \quad (1.53)$$

The expression

$$\varphi_i = \frac{1}{4\pi\epsilon_0} \sum_{k=1} \frac{q_k}{r_{ik}} \quad (1.54)$$

describes the potential produced by all the charges except q_i at the point where the charge q_i is located. Thus, we get the interaction energy in the form:

$$W = \frac{1}{2} \sum_{i=1}^N q_i \varphi_i \quad (1.55)$$

1.11 Energy of a Charged Conductor

The charge q on a conductor can be considered as a system of point charges q_i . The surface of a conductor is equipotential. Thus, having in mind the expression (1.46) we can write

$$W = \frac{1}{2} q \varphi = \frac{q^2}{2C} = \frac{C \varphi^2}{2} \quad (1.56)$$

1.12 Energy of a Charged Capacitor

Assume the potential of a capacitor plate carrying the charge $+q$ is φ_1 , and that of a plate carrying the charge $-q$ is φ_2 . Then, using the expression (1.55) we get

$$\begin{aligned} W &= \frac{1}{2} [(+q)\varphi_1 + (-q)\varphi_2] = \frac{1}{2} q(\varphi_1 - \varphi_2) = \frac{1}{2} qU \\ &= \frac{q^2}{2C} = \frac{CU^2}{2} \end{aligned} \quad (1.57)$$

Having in mind that $U/d=E$, $S \cdot d=V$ and the capacitance of a parallel-plate capacitor $C = \frac{\epsilon_0 \epsilon S}{d}$, we can rewrite the equation (1.57) in the form

$$W = \frac{\epsilon_0 \epsilon E^2}{2} V = \omega V, \quad (1.58)$$

where, the energy density

$$\omega = \frac{\epsilon_0 \epsilon E^2}{2} \quad (1.59)$$

Equation (1.59) holds everywhere.

Examples

Problem 1.

Determine the strength of the electric field generated by a straight piece of string carrying an electric charge with a linear density γ , at a point O that is r_0 distant from the string. The angles α_1 and α_2 are specified (Figure 1).

Solution: The field is not symmetric. It is extremely difficult to enclose a piece of string with a surface using which it would be fairly easy to calculate, via Gauss law, the flux of vector \mathbf{E} . We partition the string into segments so small that the charge carried by each can be considered point-like. We select one such segment of length dl carrying a charge $dQ = \gamma dl$ (Figure 1).

At point O the field generated by this charge has a strength of

$$dE = \frac{dQ}{4\pi\epsilon_0 r^2} = \frac{\gamma dl}{4\pi\epsilon_0 r^2} \quad (2)$$

From triangle ADO we get

$$r = r_0 / \cos \alpha$$

Since $|AC| = r d\alpha = r_0 d\alpha / \cos \alpha$, we find that triangle ABC yields

$$dl = |AC| / \cos \alpha = r_0 d\alpha / \cos^2 \alpha$$

Substituting the values of r and dl into Eq. 2, we get

$$dE = \frac{\gamma d\alpha}{4\pi\epsilon_0 r_0} \quad (3)$$

The projections of vector $d\mathbf{E}$ on the X and Y axes are

$$dE_x = \frac{\gamma \cos \alpha d\alpha}{4\pi\epsilon_0 r_0} \quad (4)$$

$$dE_y = \frac{\gamma \sin \alpha d\alpha}{4\pi\epsilon_0 r_0} \quad (5)$$

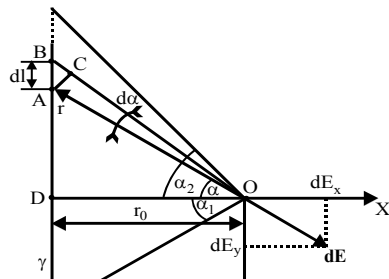

Figure 1.

Integrating 4 and 5 we find the projections (or components) of the sought vector \mathbf{E} on the X and Y axes:

$$dE_x = \int_{-\alpha_1}^{+\alpha_1} \frac{\gamma \cos \alpha d\alpha}{4\pi\epsilon_0 r_0} = \frac{\gamma}{4\pi\epsilon_0 r_0} (\sin \alpha_1 + \sin \alpha_2) \quad (6)$$

$$dE_y = \int_{-\alpha_1}^{+\alpha_1} \frac{\gamma \sin \alpha d\alpha}{4\pi\epsilon_0 r_0} = \frac{\gamma}{4\pi\epsilon_0 r_0} (\cos \alpha_1 - \cos \alpha_2) \quad (7)$$

Clearly, the field generated by a charged infinitely straight string, constitutes a particular case of the field generated by a piece of charged straight string. Indeed, for $\alpha_1 = -\pi/2$ and $\alpha_2 = +\pi/2$, Eq. 6 and 7 yield $E_x = \gamma/2\pi\epsilon_0 r_0$ and $E_y = 0$.

Problem 2.

An infinitely long string uniformly charged with a linear density $\gamma_1 = +3 \cdot 10^{-7}$ C/m and a segment of length $l = 20$ cm uniformly charged with a linear density $\gamma_2 = +2 \cdot 10^{-7}$ C/m lie in a plane at right angles to each other and separated by a distance $r_0 = 10$ cm. Determine the force with which these two bodies interact.

Solution: Two objects constitute the physical system, the infinitely long string and the segment. Neither of the two can be considered a particle. The physical phenomenon consists of the effect that the field of the string has on the charge of the segment. We wish to find the force of this interaction. The charge $Q_2 = \gamma_2 l$ carried by the segment is positioned in the electric field of the string, which is known.

It would seem that to find the force acting on the charge we need only use the formula $F = Q_2 E$, where $E = \gamma_1 / 2\pi\epsilon_0 r_0$. This is not correct, however, since the formula is valid also in the case of a point charge (Q_2 is distributed over the segment). On different sections (of equal length) of the segment of length l different forces are acting. Therefore, to calculate the force with which the nonhomogeneous field generated by the string acts on the distributed charge Q_2 we use the method of differentiation and successive integration. We partition segment l into sections of length dx so small that the charge $dQ = \gamma_2 dx$ of each section can be considered a point charge. The charge dQ is in the electric field of the string. Since this is a point charge, the force acting on it is

$$dF = EdQ = \frac{\gamma_1 \gamma_2}{2\pi\epsilon_0 x} dx$$

where x is the distance from charge dQ to the string.

We now have the differential of the sought quantity. The force acting on each section of the segment depends on the distance x from the segment to the string, and so we select x as the variable of integration (it varies from $x_1 = r_0$ to $x_2 = r_0 + l$). Integrating previous equation with respect to x , we get

$$F = \int_{r_0}^{r_0+l} \frac{\gamma_1 \gamma_2}{2\pi\epsilon_0 x} dx = \frac{\gamma_1 \gamma_2}{2\pi\epsilon_0} \ln\left(1 + \frac{l}{r_0}\right)$$

Substitution of numerical values yields the result $F \approx 1.2 \cdot 10^{-3}$ N.

The terms of the above problem can be changed by placing the segment parallel to the string, at an angle to the string, in a plane perpendicular to the string, and so on. All these variants can be solved by the same method.

Problem 3.

A straight infinitely long cylinder of radius $R_0 = 10$ cm is uniformly charged with electricity with a surface density $\sigma = +10^{-12}$ C/m². The cylinder serves as a source of electrons, with the velocity vector of the emitted electrons perpendicular to its surface. What must the electron velocity be to ensure that the electrons can move away from the axis of the cylinder to a distance greater than $r = 10^3$ m?

Solution: The physical system consists of two objects: the positively charged cylinder and an electron. The physical phenomenon consists of the electron moving in a decelerated manner in the electric field of the cylinder. We wish to find one of the parameters of motion, the electron velocity.

To describe the motion of the electron we must first calculate the electric field of the cylinder. The charge on the cylinder cannot be considered a point charge. We apply Gauss' law. For this we surround the cylinder with a cylindrical surface (coaxial with the cylinder) of an arbitrary radius $r > R_0$ (Figure 3). In view of the symmetry of the problem, the electric vector \mathbf{E} of the field of the cylinder is perpendicular at all points to the constructed cylindrical surface. Hence, the flux of \mathbf{E} out of the cylindrical surface of length l is

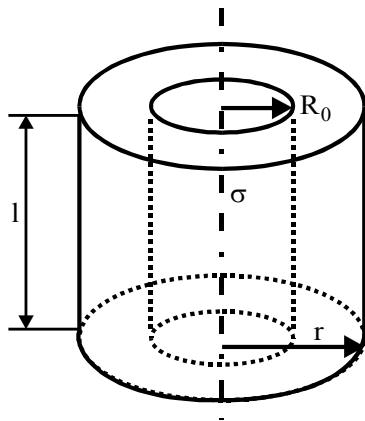

Figure 3

By Gauss' theorem,

$$\Phi_E = 2\pi r l E$$

$$2\pi r l E = 2\pi R_0 l \sigma / \epsilon_0$$

whence

$$E = \frac{R_0 \sigma}{\epsilon_0 r} \quad (1)$$

Now, by applying the dynamical method we find that Newton's second law yields

$$m_e \frac{d^2 r}{dt^2} = -e \frac{R_0 \sigma}{\epsilon_0 r},$$

where m_e is the electron mass, and e is the electron charge. From the standpoint of physics the problem is

solved.

It would be solved completely if we were to solve the above differential equation and obtain the law of motion of the electron $r = r(t)$. Knowing this law, we could find the law of variation of the electron's velocity with time, $v = v(t)$, and so on. But instead let us apply the law of energy conservation. By this law,

$$\frac{m_e v_0^2}{2} - e\varphi_0 = -e\varphi, \quad (2)$$

where φ_0 is the potential of the cylinder, and φ the potential of the field of the cylinder at a point r distant from the cylinder's axis. Employing the relationship $E = -d\varphi/dr$ that exists between the field strength E and potential φ and allowing for Eq.1, we arrive at the following differential equation:

$$\frac{R_0 \sigma}{\epsilon_0 r} = -\frac{d\varphi}{dr}.$$

Integrating, we find that

$$\varphi = -\frac{R_0 \sigma}{\epsilon_0} \ln r + C \quad (3)$$

with C being an arbitrary constant. Hence,

$$\varphi_0 = -\frac{R_0 \sigma}{\epsilon_0} \ln R_0 + C \quad (4)$$

The system of Equations 2,3,4 yields the following value for the sought initial velocity of electron:

$$v_0 = \sqrt{\frac{2eR_0\sigma \ln(r/R_0)}{\epsilon_0 m_e}}, \quad v_0 \approx 3.7 \cdot 10^5 \text{ m/s.}$$

Problem 4

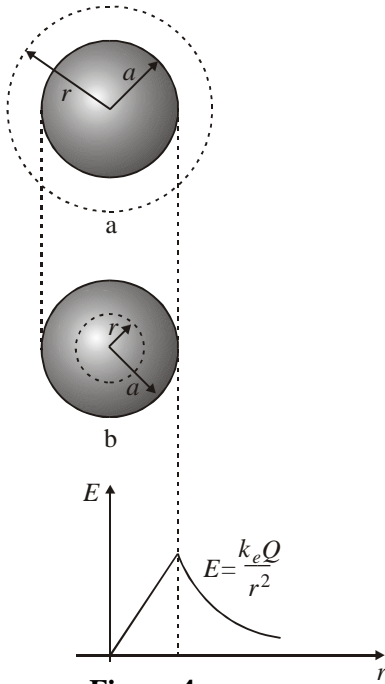

Figure 4

An insulating sphere of radius a has a uniform charge density ρ and a total positive charge Q (see Figure 4). (a) Calculate the magnitude of the electric field at a point outside the sphere.

On Figure 4:

A uniformly charged insulating sphere of radius a and total charge Q . (a) The field at a point exterior to the sphere is $k_e Q/r^2$. (b) The field inside the sphere is due only to the charge *within* the gaussian surface and is given by $(k_e Q/a^3)r$.

A plot of E versus r for a uniformly charged insulating sphere. The field inside the sphere ($r < a$) varies linearly with r . The field outside the sphere ($r > a$) is the same as that of a point charge Q located at the origin.

Solution: Since the charge distribution is spherically symmetric, we select a spherical gaussian surface of radius r , concentric with the sphere, as in Fig.4a. Gauss' law gives

$$\Phi_c = \oint \mathbf{E} d\mathbf{A} = \oint E dA = \frac{q}{\epsilon_0}$$

By symmetry, E is constant everywhere on the surface, and so it can be removed from the integral Therefore

$$\oint E dA = E \oint dA = E(4\pi r^2) = \frac{4}{3} \pi a^3 \rho \frac{1}{\epsilon_0} = \frac{Q}{\epsilon_0}$$

where we have used the fact that the surface area of a sphere is $4\pi r^2$. Hence, the magnitude of the field at a distance r from the center of the sphere

$$E = \frac{Q}{4\pi\epsilon_0 r^2} = k_e \frac{Q}{r^2} \quad (\text{for } r > a)$$

Note that this result is identical to that obtained for a point charge. Therefore, we conclude that, for a uniformly charged sphere, the field in the region external to the sphere is *equivalent* to that of a point charge located at the center of the sphere.

(b) Find the magnitude of the electric field at a point inside the sphere.

Reasoning and Solution: In this case we select a spherical gaussian surface with radius $r < a$, concentric with the charge distribution (see Figure 4b). Let us denote the volume of this smaller sphere by V' . To apply Gauss' law in this situation, it is important to recognize that the charge q_{in} within the gaussian surface of volume V' is a quantity less than the total charge Q . To calculate the charge q_{in} , we use the fact that $q_{in} = \rho V'$, where ρ is the charge per unit volume and V' is the volume enclosed by the gaussian surface, given by $V' = 4/3\pi r^3$ for a sphere. Therefore,

$$q_{in} = \rho V' = \rho(4/3\pi r^3)$$

The magnitude of the electric field is constant everywhere on the spherical gaussian surface and is normal to the surface at each point. Therefore, Gauss' law in the region $r < a$ gives

$$\oint E dA = E \oint dA = E(4\pi r^2) = \frac{q_{in}}{\epsilon_0}$$

Solving for E gives

$$E = \frac{q_{in}}{4\pi\epsilon_0 r^2} = \frac{\rho \frac{4}{3}\pi r^3}{4\pi\epsilon_0 r^2} = \frac{\rho}{3\epsilon_0} r$$

Since by definition $\rho = Q / \frac{4}{3}\pi a^3$, this can be written

$$E = \frac{Qr}{4\pi\epsilon_0 a^3} = \frac{k_3 Q}{a^3} r \quad (\text{for } r < a)$$

Note that this result for E differs from that obtained in part (a). It shows that $E \rightarrow 0$ as $r \rightarrow 0$, as you might have guessed based on the spherical symmetry of the charge distribution. Therefore, the result fortunately eliminates the singularity that would exist at $r = 0$ if E varied as $1/r^2$ inside the sphere. That is, if $E \propto 1/r^2$, the field would be infinite at $r = 0$, which is clearly a physically impossible situation. A plot of E versus r is shown in Figure 4.

Problem 5

An insulating solid sphere of radius R has a uniform positive charge density with total charge Q (Figure 5). (a) Find the electric potential at a point outside the sphere, that is, for $r > R$. Take the potential to be zero at $r = \infty$.

Solution In Example 4, we found from Gauss' law that the magnitude of the electric field outside a uniformly charged sphere is

$$E_r = k_e \frac{Q}{r^2} \quad (\text{for } r > R)$$

where the field is directed radially outward when Q is positive.

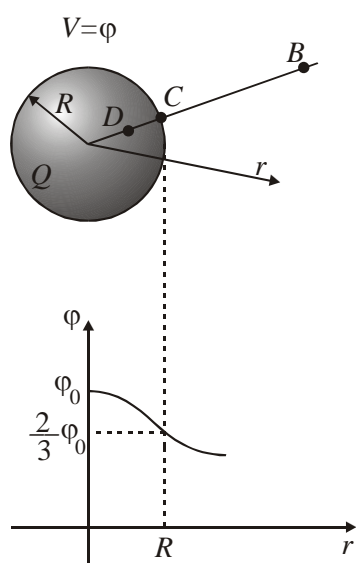

Figure 5

A uniformly charged insulating sphere of radius R and total charge Q . The electric potentials at points B and C are equivalent to those produced by a point charge Q located at the center of the sphere.

A plot of the electric potential V versus the distance r from the center of a uniformly charged, insulating sphere of radius R . The curve for V_D inside the sphere is parabolic and joins smoothly with the curve for V_B outside the sphere, which is hyperbola. The potential has a maximum value ϕ_0 at the center of the sphere.

To obtain the potential at an exterior point, such as B in Figure 5, we substitute this expression for E into equation for potential at any point. Since $\mathbf{E} \cdot d\mathbf{s} = E_r dr$ in this case, we get

$$V_B = -\int_{\infty}^r \mathbf{E} \cdot d\mathbf{s} = -\int_{\infty}^r E_r dr = -k_e Q \int_{\infty}^r \frac{dr}{r^2}$$

$$V_B = k_e \frac{Q}{r} \quad (\text{for } r > R)$$

Note that the result is identical to that for the electric potential due to a point charge. Since the potential must be continuous at $r = R$, we can use this expression to obtain the potential at the surface of the sphere. That is, the potential at a point such as C in Fig.5 is

$$V_C = k_e \frac{Q}{R} \quad (\text{for } r = R)$$

(b) Find the potential at a point inside the charged sphere, that is, for $r < R$.

Solution In Example 12 we found that the electric field inside a uniformly charged sphere is

$$E_r = k_e \frac{Q}{R^3} r \quad (\text{for } r < R)$$

We can use this result to evaluate the potential difference $V_D - V_C$, where D is an interior point:

$$V_D - V_C = -\int_R^r E_r dr = -\frac{k_e Q}{R^3} \int_R^r r dr = \frac{k_e Q}{2R^3} (R^2 - r^2)$$

Substituting $V_C = k_e Q/R$ into this expression and solving for V_D , we get

$$V_D = \frac{k_e Q}{2R} \left(3 - \frac{r^2}{R^2} \right) \quad (\text{for } r < R)$$

At $r = R$, this expression gives a result for the potential that agrees with that for the potential at the surface, that is, V_C . A plot of V versus r for this charge distribution is given in Figure 5.

Problem 6

A cylindrical conductor of radius a and charge Q is coaxial with a larger cylindrical shell of radius b and charge $-Q$ (Figure 6a). Find the capacitance of this cylindrical capacitor if its length is l .

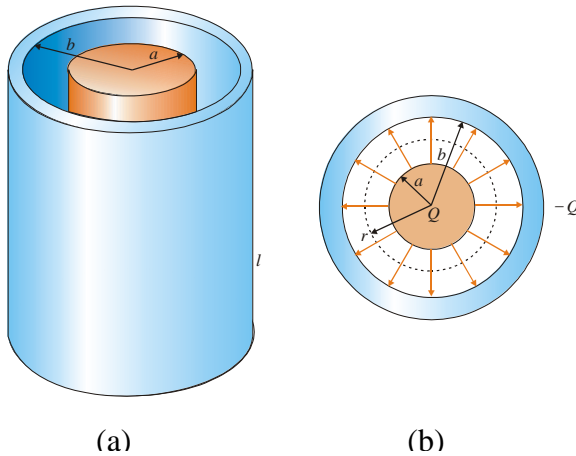

Figure 6.

(a) A cylindrical capacitor consists of a cylindrical conductor of radius a and length l surrounded by a coaxial cylindrical shell of radius b . (b) The end view of a cylindrical capacitor. The dashed line represents the end of the cylindrical gaussian surface of radius r and length l .

Reasoning and Solution: If we assume that l is long compared with a and b , we can neglect end effects. In this case, the field is perpendicular to the axis of the cylinders

and is confined to the region between them (Figure 6 b). We must first calculate the potential difference between the two cylinders, which is given in general by

$$V_b - V_a = -\int_a^b \mathbf{E} \cdot d\mathbf{s}$$

where \mathbf{E} is the electric field in the region $a < r < b$. The electric field of a cylinder of charge per unit length λ is $E = 2k_e\lambda/r$. The same result applies here, since the outer cylinder does not contribute to the electric field inside it. Using this result and noting that \mathbf{E} is along r in Figure 6b, we find that

$$V_b - V_a = -\int_a^b E_r \cdot dr = -2k_e\lambda \int_a^b \frac{dr}{r} = -2k_e\lambda \ln\left(\frac{b}{a}\right)$$

Substituting this into equation for the capacitance and using the fact that $\lambda = Q/l$, we get

$$C = \frac{Q}{V} = \frac{Q}{\frac{2k_e Q}{l} \ln\left(\frac{b}{a}\right)} = \frac{l}{2k_e \ln\left(\frac{b}{a}\right)}$$

where V is the magnitude of the potential difference, given by $2k_e\lambda \cdot \ln(b/a)$, a positive quantity. That is, $V = V_a - V_b$ is positive because the inner cylinder is at the higher potential. Our result for C makes sense because it shows that the capacitance is proportional to the length of the cylinder. As you might expect, the capacitance also depends on the radii of the two cylindrical conductors. As an example, a coaxial cable consists of two concentric cylindrical conductors of radii a and b separated by an insulator. The cable carries currents in opposite directions in the inner and outer conductors. Such a geometry is especially useful for shielding an electrical signal from external influences. From the latter equation we see that the capacitance per unit length of a coaxial cable is

$$\frac{C}{l} = \frac{1}{2k_e \ln\left(\frac{b}{a}\right)}$$

Problem 7.

A thin ring of radius R has been uniformly charged with an amount of electricity Q and placed in relation to a conducting sphere in such a way that the center of the sphere, O , lies on the ring's axis at a distance of l from the plane of the ring (Figure 7). Determine the potential of the sphere.

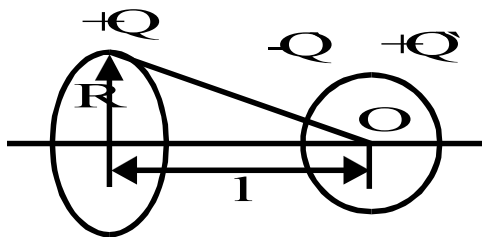

Figure 7

Solution: The conducting sphere is situated in the field of the ring. We wish to calculate the potential of the conductor. This constitutes a basic problem of field theory. Since the field is not symmetric, it is doubtful that Gauss' law of flux will lead to meaningful results. Let us employ the superposition method.

The field of the ring induced charges of magnitude $-Q$ and $+Q$ on the conducting sphere. The resultant field is generated by three charges: Q , $-Q$, and $+Q$. Hence, according to the superposition principle, the potential of the conducting sphere is $\phi = \phi_1 + \phi_2 + \phi_3$ where ϕ_1, ϕ_2, ϕ_3 are the potentials of the fields generated by the charges Q , $-Q$, and $+Q$, respectively. But at what point of the sphere? The answer is: at any point, since the potential of a conductor placed in an electrostatic field is the same for all points of the conductor.

In our case, the entire volume bound by the conducting sphere is equipotential. Thus, we need only calculate the potential at the most convenient point, the center of the sphere. Indeed, notwithstanding the fact that we know neither the values of the induced charges $-Q'$ and $+Q''$ nor the distributions of the respective charge densities $-\sigma'$ and $+\sigma''$ over the sphere, we can state that the total potential of the field of these charges at the special point (the center of the sphere) is zero: $\varphi_2 + \varphi_3 = 0$ (the induced charges $-Q'$ and $+Q''$ lie at equal distances from the center of the sphere, are equal in magnitude, $|-Q'| = |+Q''|$, and are opposite in sign). Hence, we need only to calculate the potential φ_1 of the ring's field at O (Figure 7):

$$\varphi_1 = \frac{Q}{4\pi\epsilon_0(1^2 + R^2)^{1/2}}.$$

This constitutes the potential of the sphere, $\varphi = \varphi_1$.

Electric Field in Dielectrics

2.1. Dipole Electric Moment

In a strict sense, dielectrics (or insulators) are substances which cannot conduct an electric current. Ideal isolators do not exist in nature. All substances, even of to a negligible extent, conduct an electric current. But substances called conductors conduct a current from 10^{15} to 10^{20} times better than substances called dielectrics.

A molecule is a system with a total charge of zero. To characterize its electrical properties, the quantity called the *dipole electric moment* (\mathbf{p}) is used:

$$\mathbf{p} = \sum q_i \mathbf{r}_i \quad (2.1)$$

(summation is performed both over the electrons and nuclei). If the system has the total electric charge equal to zero, the magnitude of the dipole moment does not depend on the choice of the coordinate system origin. Indeed, let us make a transformation

$$\mathbf{r}'_i = \mathbf{r}_i + \mathbf{a}, \quad (2.2)$$

where \mathbf{a} is the shift of the coordinate origin. Obviously,

$$\mathbf{p}' = \sum q_i \mathbf{r}'_i = \sum q_i (\mathbf{r}_i + \mathbf{a}) = \sum q_i \cdot \mathbf{r}_i + \mathbf{a} \cdot \sum q_i = \mathbf{p} \quad (2.3)$$

The electrons in a molecule are in motion, and the quantity (2.3) constantly changes. The velocities of electrons are so high, however, that the mean value of the dipole moment(2.3) is detected in practice:

$$\mathbf{p} = \sum q_i \langle \mathbf{r}_i \rangle. \quad (2.4)$$

In other words, we shall consider that the electrons are at rest relative to the nuclei at certain points obtained by averaging the positions of the electrons in time.

The behavior of a molecule in an external electric field is determined by its dipole moment. Let us calculate the potential energy of a molecule located in an external field. Having in mind that the magnitude of $\langle \mathbf{r}_i \rangle$ is small, we can write the potential at the point where i -th charge is in the form

$$\varphi_i = \varphi + \nabla \varphi \cdot \langle \mathbf{r}_i \rangle. \quad (2.5)$$

Hence,

$$W = \sum q_i \varphi_i = \sum q_i (\varphi + \nabla \varphi \cdot \langle \mathbf{r}_i \rangle) = \varphi \sum q_i + \nabla \varphi \sum q_i \langle \mathbf{r}_i \rangle \quad (2.6)$$

Taking into account that $\sum q_i = 0$ and substituting $-\mathbf{E}$ for $\nabla \varphi$ we arrive at

$$W = -\mathbf{p}\mathbf{E} = -pE \cos \alpha. \quad (2.7)$$

Differentiating this expression with respect to α we get the rotational momentum (torque) $T=pE \sin \alpha$, or in the vector form:

$$\mathbf{T} = [\mathbf{p}\mathbf{E}]. \quad (2.8)$$

Differentiating Equation (2.7) with respect to linear coordinates (x, y, z) we get the force acting on the dipole. For example, when a dipole is located in an inhomogeneous field that is symmetric relative to the x -axis,

$$F_x = -\frac{\partial W}{\partial x} = p \frac{\partial E}{\partial x} \cos \alpha; F_y = F_z = 0. \quad (2.9)$$

Here, α is an angle between \mathbf{p} and \mathbf{E} . For a system containing only two charges $+q$ and $-q$ (see Figure 2.1) separated by a distance l , the dipole moment

$$\mathbf{p} = ql, \quad (2.10)$$

where \mathbf{l} is a vector having direction from the negative charge to the positive one.

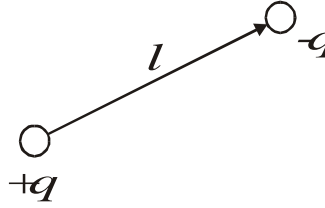

Figure 2.1.

2.2 Polar and Non-polar Molecules

The interpretation of any real system by two charges of different signs holds if we mean by $-q$ and $+q$ the *centers* (r_c) of the *spherical distribution*, correspondingly, of the negative and positive charges:

$$\left. \begin{aligned} \mathbf{r}_c &= \sum q_i \cdot \mathbf{r}_i, \text{ or} \\ \mathbf{r}_c &= \int \mathbf{r} \cdot \rho dV \end{aligned} \right\} \quad (2.11)$$

(summation or integration is taken over only the charges of the same sign).

In symmetrical molecules (such as H_2 , O_2 , N_2), the centers of the spatial distribution of the positive and negative charges coincide in the absence of an external electric field. These molecules have no intrinsic dipole moments and are called *non-polar*. In asymmetrical molecules (such as CO , NH , HCO) the centers of the spatial distribution of the charges of opposite signs are displaced relative to each other, thus these molecules have an intrinsic dipole moment and are called *polar*.

Under the action of an external electric field, the charges of a non-polar molecule become displaced relative to one another; the positive ones in the direction of the field, the negative ones against the field. As a result, the molecule acquires an induced dipole moment whose magnitude is proportional to the field strength:

$$\mathbf{p} = \beta \epsilon_0 \mathbf{E}, \quad (2.12)$$

where ϵ_0 is the electric constant, and β is a quantity called the *polarizability* of a molecule.

The process of polarization of a non-polar molecule proceeds as if the positive and negative charges of the molecule were bound to each other by electric forces. In an external field a non-polar molecule is said to behave itself like an electric dipole. The action of an external field on a polar molecule consists mainly in turning of molecules so that its dipole moment is arranged in the direction of the field. An external field does not virtually affect the magnitude of a dipole moment. Consequently, a polar molecule behaves in an external field like a rigid dipole.

2.3 Polarization of Dielectrics

In the absence of an external electric field, the dipole moments of the molecules of a dielectric *usually* either equal zero (non-polar molecules) or are distributed in space by directions chaotically (polar molecules). In both cases, the total dipole moment of dielectric equals zero. (We say *usually*, because there are some substances that can have a dipole moment in the absence of an external field).

To characterize the polarization of a dielectric at a given point, the vector quantity \mathbf{P} called the *polarization of a dielectric* is used:

$$\mathbf{P} = \frac{\sum \mathbf{p}_i}{\Delta V}. \quad (2.13)$$

Here, ΔV is an infinitely small (in physical sense) volume, $\sum \mathbf{p}_i$ is the resultant dipole moment of this volume.

The polarization of an isotropic (we have no possibility to discuss the general case of anisotropic dielectrics) is proportional to the field strength

$$\mathbf{P} = \chi \epsilon_0 \cdot \mathbf{E}, \quad (2.14)$$

where χ is a quantity independent of \mathbf{E} and it is called the *electric susceptibility* of a dielectric. Equation (2.14) holds for not too large magnitudes of \mathbf{E} .

For dielectrics built of polar molecules, the orienting action of the external field is counteracted by the thermal motion of molecules tending to scatter their dipole moments in all directions. As a result, a certain preferable orientation of dipole moments of molecules sets in the direction of the field. The electric susceptibility of such dielectrics varies inversely with their absolute temperature.

In ionic crystals, the separate molecules lose their individuality. An entire crystal is, as it were, a single giant molecule. The lattice of an ionic crystal can be considered as two lattices inserted into each other, one of which is formed by the positive, and the other by the negative ions. When an external field acts on the crystal ions, both lattices are displaced relative to each other, which leads to polarization of dielectric. The polarization in this case is related with the field strength by Equation (2.14). We remind once more that the linear relation between \mathbf{E} and \mathbf{P} described by Equation (2.14) is valid only for not too strong fields.

2.4 Space and Surface Bound Charges

Polarization of a dielectric causes the surface density (σ'), and in some cases also the volume density of the bound charges becomes different from zero. (We remind our readers that *usually* for not polarized dielectrics, these quantities equal zero).

The Figure 2.2 shows schematically a polarized dielectric with non-polar (a) and polar (b) molecules. The polarization is attended by the appearance of a surplus of bound charges of the same sign in the thin surface layer of the dielectric.

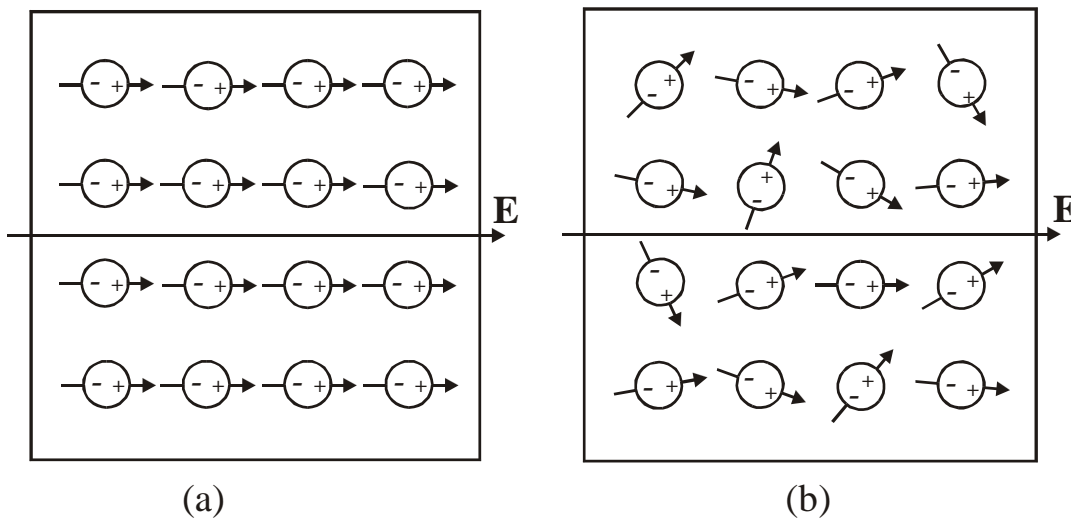

Figure 2.2.

To find the relation between the polarization \mathbf{P} and surface density of bound charges σ' , let us consider an infinite plane-parallel plate of a homogeneous dielectric placed in a homogeneous electric field (see Figure 2.3).

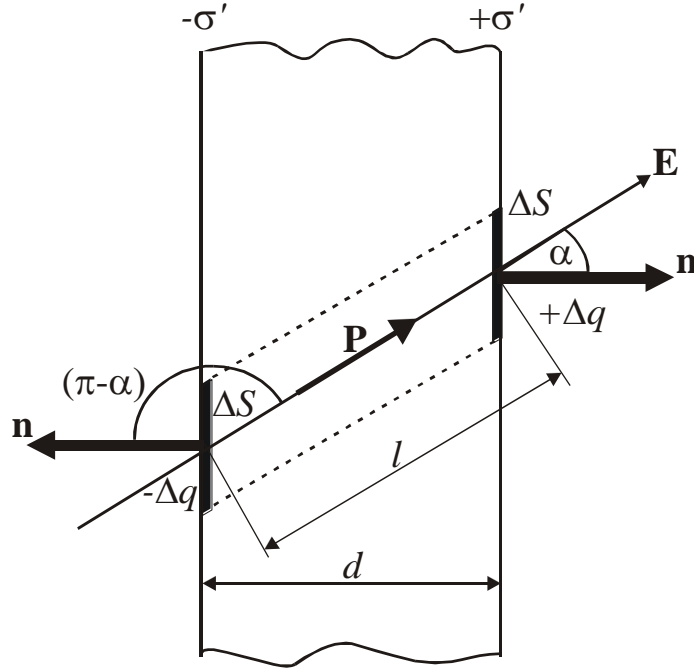

Figure 2.3

Let us mentally separate an elementary volume in the plate in the form of a very thin cylinder with generatrices parallel to \mathbf{E} in the dielectric, and with bases of area ΔS coinciding with the surfaces of the plate. A dipole electric moment of this volume

$$\Delta p = P dV = P l \Delta S \cdot \cos \alpha. \quad (2.15)$$

On the other hand, it can be expressed as follows:

$$\Delta p = \sigma' \cdot l \cdot \Delta S. \quad (2.16)$$

Comparing Equations (2.15) and (2.16) we conclude that

$$\sigma' = P \cdot \cos \alpha = P_n, \quad (2.17)$$

where P_n is the projection of polarization onto an outward normal to the relevant surface. Using Equation (2.14) we can write Equation (2.17) as

$$\sigma' = \chi \varepsilon_0 E_n, \quad (2.18)$$

where E_n is the normal component of the field strength inside the dielectric. According to equation (2.18), at the points where the field lines emerge from the dielectric ($E_n > 0$), positive bound charges come up to the surface, while where the field lines enter the dielectric ($E_n < 0$), negative surface charges appear.

Equations (2.17) and (2.18) also hold in the most general case when an inhomogeneous dielectric of an arbitrary shape is located in an inhomogeneous electric field. By P_n and E_n we must understand now the normal component of the relevant vector taken in direct proximity to the surface element for which σ' is being determined. Analogous but a little more tiresome calculations lead to the expression describing the spatial density of bound charges:

$$\rho' = -\nabla \cdot \mathbf{P}. \quad (2.19)$$

I.e., the density of bound charges equals the divergence of the polarization vector \mathbf{P} taken with the opposite sign.

2.5 Electric Displacement Vector

Bound charges differ from extraneous ones only in that they cannot leave the confines of the molecules which they are in. Otherwise, they have the same properties as all other charges. In particular, they are the sources of an electric field. Therefore, when the density of the bound charges ρ' differs from zero, equation (1.12) must be written as follows:

$$\nabla \mathbf{E} = \frac{1}{\epsilon_0} (\rho + \rho'). \quad (2.20)$$

Here, ρ' is the density of the extraneous charges. Equation (2.20) is of virtually no use for finding the vector \mathbf{E} because it expresses the properties of the unknown quantity \mathbf{E} through bound charges, which in turn are determined by the unknown quantity \mathbf{E} .

Calculation of the fields is often simplified if we introduce an auxiliary quantity whose source are only extraneous charges ρ . To establish what this quantity looks like, let us substitute equation (2.19) for ρ' into equation (2.20):

$$\nabla \mathbf{E} = \frac{1}{\epsilon_0} (\rho - \nabla \mathbf{P}), \quad (2.21)$$

whence it follows that

$$\nabla (\epsilon_0 \mathbf{E} + \mathbf{P}) = \rho. \quad (2.22)$$

The quantity

$$\mathbf{D} = \epsilon_0 \mathbf{E} + \mathbf{P} \quad (2.23)$$

is called the *electric displacement*, it is just the required quantity. Inserting equation (2.14) for \mathbf{P} , we get

$$\mathbf{D} = \epsilon_0 \mathbf{E} + \epsilon_0 \chi \mathbf{E} = \epsilon_0 (1 + \chi) \mathbf{E}. \quad (2.24)$$

The dimensionless quantity

$$\epsilon = 1 + \chi \quad (2.25)$$

is called the *relative permittivity* (or simply *permittivity*) of a medium. Thus,

$$\mathbf{D} = \epsilon_0 \epsilon \mathbf{E} \quad (2.26)$$

According to Equation (2.26), the vector \mathbf{D} is proportional to the vector \mathbf{E} . We remind our readers that we are dealing with isotropic dielectrics. In anisotropic dielectrics, the vectors \mathbf{E} and \mathbf{D} , generally speaking, are not collinear.

In accordance with Equations (1.7) and (2.26), the electric displacement of the field of a point charge in a vacuum ($\epsilon = 1$) is

$$\mathbf{D} = \frac{1}{4\pi} \cdot \frac{q}{r^2} \cdot \mathbf{e}_r. \quad (2.27)$$

Equation (2.22) can be written as

$$\nabla \mathbf{D} = \rho. \quad (2.28)$$

Integration of this Equation over an arbitrary volume V yields

$$\int_V \nabla \mathbf{D} dV = \int_V \rho dV, \quad (2.29)$$

or

$$\oint_S \mathbf{D} dS = \int_V \rho dV. \quad (2.30)$$

The quantity on the left-hand side of (2.30) is Φ_D , the flux of the vector \mathbf{D} through closed surface S , while that on the right-hand side is the sum of the extraneous charges $\sum q_i$ enclosed by this surface. Hence,

$$\Phi_D = \sum q_i, \quad (2.31)$$

Equation (2.31) is known to be the Gauss' theorem for dielectric. This statement holds also for any inhomogeneous dielectric.

The field of the vector \mathbf{D} can be depicted with the aid of *electric displacement lines*. Their direction and density are determined in exactly the same way as for the lines of the vector \mathbf{E} . The lines of vector \mathbf{E} can begin and terminate at both extraneous and bound charges. The sources of the field of the vector \mathbf{D} are only extraneous charges. Hence, displacement lines can begin or terminate only at extraneous charges. These lines pass without interruption through points at which bound charges are placed.

2.6 Examples of Calculating the Field in Dielectrics

2.6.1 Field Inside a Flat Plate (see Figure 2.4)

Two parallel infinite planes are charged with the surface density $+\sigma$ and $-\sigma$. The field they produce in a vacuum is characterized by the strength \mathbf{E}_0 and the displacement $\mathbf{D}_0 = \epsilon_0 \mathbf{E}_0$. A plate of a homogeneous isotropic dielectric is located between the charged planes. The dielectric becomes polarized under the action of the field, and bound charges of density $\pm\sigma'$ appear on its surfaces. These charges will set up a homogeneous field inside the dielectric plate whose strength by Equation (1.19) is $E' = \frac{\sigma'}{\epsilon_0}$. In the

given case, E' is outside the dielectric. The field strength E_0 is σ/ϵ_0 . For the resultant field strength inside the dielectric we get

$$E = E_0 - E' = E_0 - \frac{\sigma'}{\epsilon_0} = \frac{1}{\epsilon_0}(\sigma - \sigma') \quad (2.32)$$

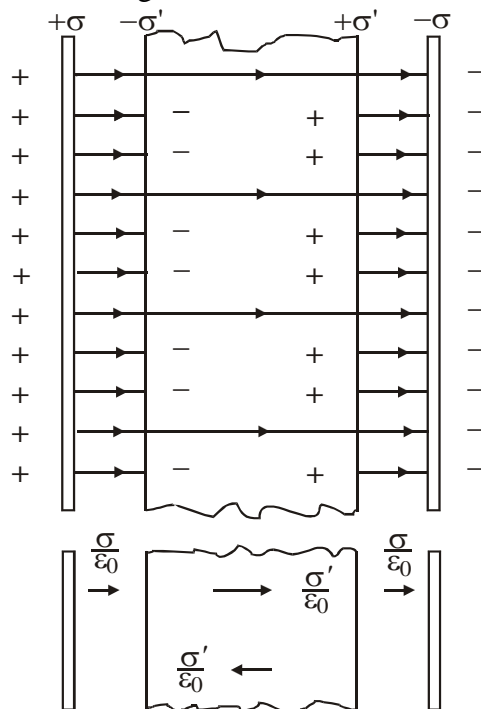

Figure 2.4

The polarization of the dielectric is due to field (2.32). The latter is perpendicular to the surfaces of the plate. Hence $E_n = E$, and in accordance with Equation (2.18), $\sigma' = \chi \epsilon_0 E$. Inserting this quantity in Equation (2.32) we have $E = E_0 - \chi E$, whence

$$E = \frac{E_0}{1 + \chi} = \frac{E_0}{\epsilon}. \quad (2.33)$$

Thus, in the given case the permittivity ϵ shows how many times the field in a dielectric weakens in comparison with the field in a vacuum. Multiplying Equation (2.33) by $\epsilon_0 \epsilon$, we get the electric displacement inside the plate

$$D = \epsilon_0 \epsilon E = \epsilon_0 E_0 = D_0. \quad (2.34)$$

Hence, the electric displacement inside the

dielectric coincides with that of the external field D_0 . Substituting σ/ϵ_0 for E_0 into equation (2.34) we find

$$D = \sigma. \quad (2.35)$$

To find σ' , let us express E and E_0 in Equation (2.32) through the charge densities:

$$\frac{1}{\epsilon_0}(\sigma - \sigma') = E = \frac{E_0}{\epsilon} = \frac{\sigma}{\epsilon_0 \epsilon} = \frac{\sigma}{\epsilon_0 \epsilon},$$

whence

$$\sigma' = \frac{\epsilon - 1}{\epsilon} \sigma. \quad (2.36)$$

2.6.2 Field Inside a Spherical Layer (see Figure 2.5)

A charged sphere of radius R is surrounded by concentric spherical layers of a homogeneous isotropic dielectric. The bound charge q'_1 distributed with the density σ'_1 will appear on the internal surface of layer ($q'_1 = 4\pi R_1^2 \sigma'_1$), and the charge q'_2 distributed with the density σ'_2 will appear on its external surface ($q'_2 = 4\pi R_2^2 \sigma'_2$). The sign of the charge q'_2 coincides with that of the charge q of the sphere, while q'_1 is of the opposite sign. The charges q'_1 and q'_2 set up a field at a distance r exceeding R_1 and R_2 , respectively, that coincides with the field of a point charge of the same magnitude (see Equation (1.15)). The charges q'_1 and q'_2 produce no field inside the surfaces

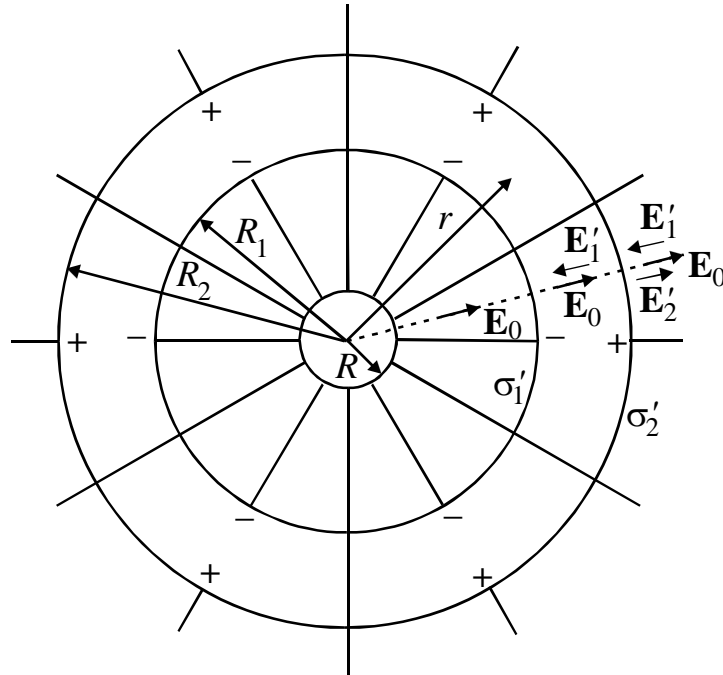

Figure 2.5.

over which they are distributed. Hence, the field strength E' inside the dielectric is

$$E' = \frac{1}{4\pi\epsilon_0} \frac{q'_1}{r^2} = \frac{1}{4\pi\epsilon_0} \cdot \frac{4\pi R_1^2 \sigma'_1}{r^2} = \frac{1}{\epsilon_0} \frac{R_1^2 \sigma'_1}{r^2} \quad (2.37)$$

and is opposite in direction to the field strength \mathbf{E}_0 . The resultant field inside the dielectric

$$E(r) = E_0 - E' = \frac{1}{4\pi\epsilon_0} \frac{q}{r^2} - \frac{1}{\epsilon_0} \frac{R_1^2 \sigma'_1}{r^2}. \quad (2.38)$$

It diminishes in proportion to $1/r^2$. So, we can write

$$\frac{E(R_1)}{E(r)} = \frac{r^2}{R_1^2}, \text{ or } E(R_1) = E(r) \cdot \frac{r^2}{R_1^2}, \quad (2.39)$$

where $E(R_1)$ is the field strength in the dielectric in direct proximity to the internal surface of the layer. It is exactly the strength that determines the quantity σ'_1 :

$$\sigma'_1 = \chi\epsilon_0 E(R_1) = \chi\epsilon_0 E(r) \frac{r^2}{R_1^2}, \quad (2.40)$$

(at each point of the surface $|E_n|=E$). Substituting expression for σ from equation (2.40) into equation (2.38) we get

$$E(r) = \frac{1}{4\pi\epsilon_0} \frac{q}{r^2} - \frac{1}{\epsilon_0} \frac{R_1^2 \chi\epsilon_0 E(r) r^2}{r^2 R_1^2} = E_0(r) - \chi E(r), \quad (2.41)$$

whence

$$E(r) = \frac{E_0(r)}{\epsilon}, \quad (2.42)$$

$$D = \epsilon_0 E_0 = D_0. \quad (2.43)$$

The field inside the dielectric changes in proportion to $1/r^2$. Therefore, the relation $\sigma'_1/\sigma'_2 = R_2^2/R_1^2$ holds. Hence, $q'_1 = q'_2$. Consequently, the fields set up by these charges at distances exceeding R_2 mutually terminate each other so that outside the spherical layer $E \stackrel{!}{=} 0$ and $E = E_0$.

Assuming that $R_1=R$ and $R_2=\infty$, we arrive at the case of a charged sphere immersed in an infinite homogeneous and isotropic dielectric. The field strength outside such a sphere is

$$E = \frac{1}{4\pi\epsilon_0} \cdot \frac{q}{\epsilon r^2}. \quad (2.44)$$

Both examples considered above are characterized by the fact that a dielectric was homogeneous and isotropic, and the surfaces enclosing it coincided with the equipotential surfaces of the field of extraneous charges. The result we have obtained in these cases is a general one. If a homogeneous and isotropic dielectric completely fills the volume enclosed by equipotential surfaces of the field of extraneous charges, then the electric displacement vector coincides with the vector of the field strength of the extraneous charges multiplied by ϵ_0 , and therefore, the field strength inside the dielectric is $1/\epsilon$ of that of the field strength of the extraneous charges in a vacuum.

If the above conditions are not satisfied, the vectors \mathbf{D} and $\epsilon_0\mathbf{E}$ do not coincide. For example, Figure 2.6 shows the field in the dielectric plate skewed relative to the planes carrying extraneous charges. The vector \mathbf{E}' is perpendicular to the faces of the plate, therefore \mathbf{E} and \mathbf{E}' are not collinear.

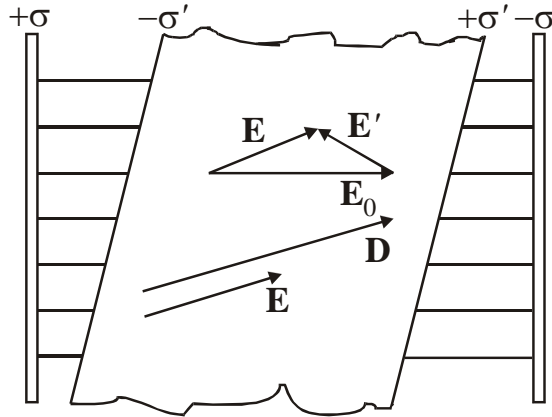
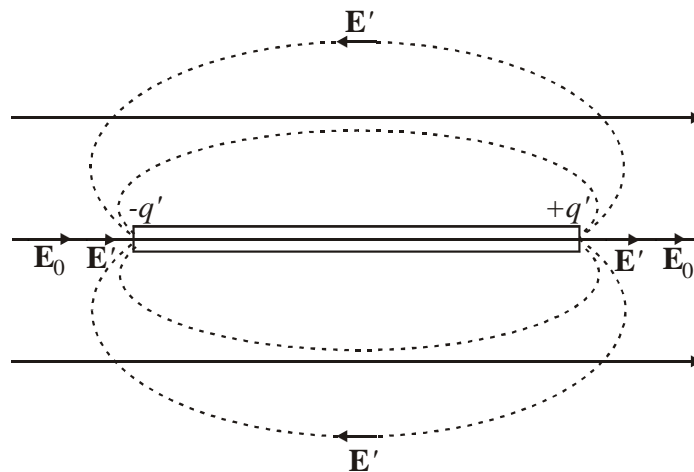

Figure 2.6

The vector \mathbf{D} has the same direction as \mathbf{E} , consequently \mathbf{D} and $\epsilon_0 E_0$ do not coincide in direction. They also fail to coincide in magnitude.

In the general case \mathbf{E}' may differ from zero outside the dielectric too (see Figure 2.7). A rod made of a dielectric is placed in initially homogeneous electric field. Owing to polarization, bound charges of opposite signs are induced at the ends of the rod. Their field outside the rod is equivalent to the field of a dipole (the dash lines). It is easy to see that the resultant field $\mathbf{E} = \mathbf{E}_0 + \mathbf{E}'$ near the ends of the rod is greater than the



field \mathbf{E}_0 .

Figure 2.7.

2.7 Conditions at the Interface Between Two Dielectrics

Let us consider the interface between two dielectrics with the permittivities ϵ_1 and ϵ_2 (see Figure 2.8). We choose an arbitrarily directed x -axis on this surface. We take a small rectangular contour of length a and width b that is partly in the first dielectric and partly in the second one.

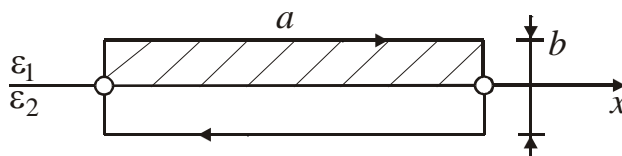

Figure 2.8

Let \mathbf{E}_1 and \mathbf{E}_2 be the field strengths inside dielectrics. Since $[\nabla\mathbf{E}]=0$, the circulation of the vector \mathbf{E} around the contour equals zero, i.e.

$$\oint \mathbf{E}_l \cdot d\mathbf{l} = E_{1,x} \cdot a - E_{2,x} \cdot a + \langle E_b \rangle \cdot 2b = 0. \quad (2.45)$$

where $\langle E_b \rangle$ is the mean value of E_l on the contour perpendicular to the interface. In the limit, when the width b of the contour tends to zero, we get

$$E_{1,x} = E_{2,x}. \quad (2.46)$$

Let us represent each of the vectors \mathbf{E}_1 and \mathbf{E}_2 as the sum of the normal and tangential components:

$$\mathbf{E}_1 = \mathbf{E}_{1,n} + \mathbf{E}_{1,\tau}; \quad \mathbf{E}_2 = \mathbf{E}_{2,n} + \mathbf{E}_{2,\tau}. \quad (2.47)$$

The equation (2.46) signifies that

$$E_{1,\tau} = E_{2,\tau}. \quad (2.48)$$

Substituting the projections of the vector \mathbf{D} divided by $\varepsilon_0\varepsilon$ for the projections of the vector \mathbf{E} , we get

$$\frac{D_{1,\tau}}{\varepsilon_0\varepsilon_1} = \frac{D_{2,\tau}}{\varepsilon_0\varepsilon_2}, \quad (2.49)$$

whence it follows that

$$\frac{D_{1,\tau}}{D_{2,\tau}} = \frac{\varepsilon_1}{\varepsilon_2}. \quad (2.50)$$

Now let us take an imaginary cylindrical surface of height h on the interface between the dielectrics (see Figure 2.9).

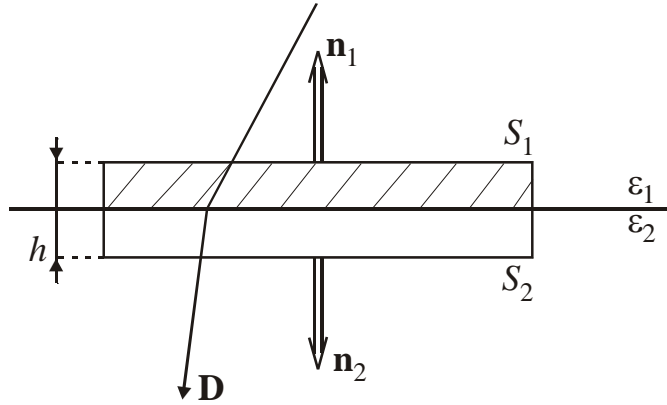

Figure 2.9

Base S_1 is on the first dielectric, and base S_2 is on the second ($S_1 = S_2 = S$). Using the Gauss theorem we can write:

$$-D_{1,n} \cdot S + D_{2,n}S + \langle D_n \rangle \cdot S_{side} = 0. \quad (2.51)$$

(We assume that there are no extraneous charges on the interface). Here, $\langle D_n \rangle$ is the mean value of D_n on the side surface of the cylinder. If the altitude of the cylinder tends to zero, the last term in equation (2.51) vanishes, and we get:

$$D_{1,n} = D_{2,n}, \quad (2.52)$$

or

$$\varepsilon_0\varepsilon_1 E_{1,n} = \varepsilon_0\varepsilon_2 E_{2,n}, \quad (2.53)$$

whence

$$\frac{E_{1,n}}{E_{2,n}} = \frac{\epsilon_2}{\epsilon_1}. \quad (2.54)$$

The results we have obtained signify that when passing through the interface between two dielectrics, the normal component of the vector \mathbf{D} and the tangential component of the vector \mathbf{E} change continuously. The tangential component of the vector \mathbf{D} and the normal component of the vector \mathbf{E} , however, are disrupted when passing through the interface.

Equations (2.48), (2.50), (2.52), and (2.54) determine the conditions which the vector \mathbf{E} and \mathbf{D} must comply with on the interface between two dielectrics (if there are no extraneous charges on this interface). We have obtained these equations for an electrostatic field. They also hold, however, for fields varying in time.

Using these equations, it is rather easy to get the law of displacement line refraction (see Figure 2.10):

$$\frac{\tan \alpha_1}{\tan \alpha_2} = \frac{\epsilon_1}{\epsilon_2}. \quad (2.55)$$

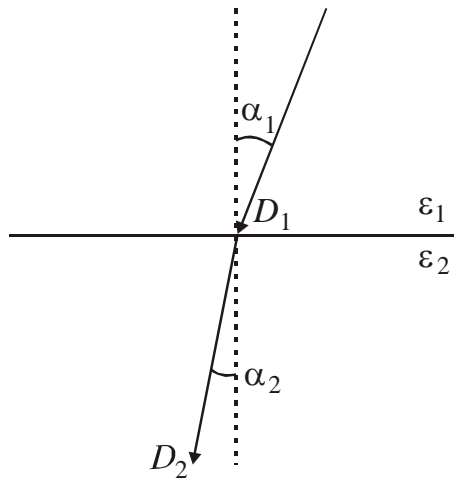

Figure 2.10

When displacement lines pass into a dielectric with a lower permittivity, the angle made by them with a normal decreases, the lines are spaced farther apart; when the lines pass into a dielectric with a higher permittivity, on the contrary, they become closer together.

2.8 Forces Acting on a Charge in a Dielectric

If we put into an electric field in a vacuum a charged body of such small dimensions that the external field within the body can be considered homogeneous, then the body will experience the force

$$\mathbf{F} = q\mathbf{E}. \quad (2.56)$$

To place a charged body in a field set up in a dielectric, a cavity must be made in the latter. In a fluid dielectric, the body itself forms the cavity by displacing the dielectric from the volume it occupies. The field inside the cavity \mathbf{E}_{cav} will differ from that in a continuous dielectric. Thus, we cannot calculate the force exerted on a charged body placed in a cavity as the product of the charge q and the field strength \mathbf{E} in the dielectric before the body was placed into it.

When calculating the force acting on a charged body in a fluid dielectric, the mechanical tension \mathbf{F}_{ten} set up on the boundary with the body must be taken into account.

Thus, the force acting on a charged body in a dielectric, generally speaking, cannot be determined by equation (2.56), and it is usually a very complicated task to calculate it. These calculations give an interesting result for a fluid dielectric. The resultant of the electric force $q\mathbf{E}_{\text{cav}}$ and the mechanical force \mathbf{F}_{ten} is found to be exactly equal to $q\mathbf{E}$, where \mathbf{E} is the field strength in the continuous dielectric

$$\mathbf{F} = q\mathbf{E}_{\text{cav}} + \mathbf{F}_{\text{ten}} = q\mathbf{E}. \quad (2.57)$$

The strength of the field produced in a homogeneous infinitely extending dielectric by a point charge is determined by equation (2.44). Hence, we get the following expression for the force of interaction of two point charges immersed in a homogeneous infinitely extending fluid dielectric

$$F = \frac{1}{4\pi\epsilon_0} \cdot \frac{q_1q_2}{\epsilon r^2}. \quad (2.58)$$

Some authors characterize equation (2.58) as “the most general expression of Coulomb’s law”. In this connection, we are going to cite Richard P. Feynman: “Many older books on electricity start with the “fundamental” law that the force between two charges is ...[equation (2.58) is given]..., a point of view is thoroughly unsatisfactory. For one thing, it is not true in general; it is true only for a world filled with a liquid. Secondly, it depends on the fact that ϵ is a constant which is only approximately true for most real materials”.

In this textbook, we are not going to discuss problems relating to the forces acting on a charge inside a cavity made in a solid dielectric.

Examples

Problem 1

A parallel-plate capacitor has a capacitance C_0 in the absence of dielectric. A slab of dielectric material of dielectric constant ϵ and thickness $d/3$ is inserted between the plates (Fig.15). What is the new capacitance when the dielectric is present?

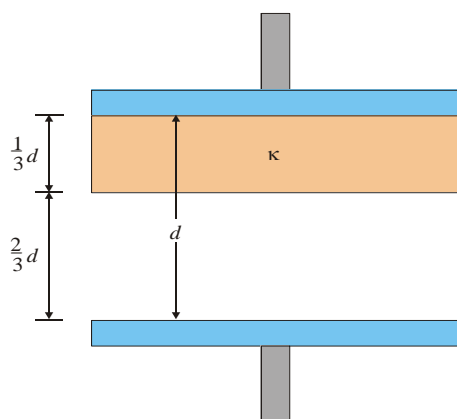

Figure 15

A parallel-plate capacitor of plate separation d partially filled with a dielectric of thickness $d/3$

Reasoning: This capacitor is equivalent of two parallel-plate capacitors of the same area

A connected in series, one (C_1) with a plate separation $d/3$ (dielectric filled) and the other (C_2) with a plate separation $2d/3$ and air between the plates (Figure 15) The two capacitances are

$$C_1 = \frac{\epsilon\epsilon_0 A}{d/3} \quad \text{and} \quad C_2 = \frac{\epsilon_0 A}{2d/3}.$$

Solution Using the equation for two capacitors combined in series, we get

$$\frac{1}{C} = \frac{1}{C_1} + \frac{1}{C_2} = \frac{d/3}{\epsilon\epsilon_0 A} + \frac{2d/3}{\epsilon_0 A} = \frac{d}{3\epsilon_0 A} \left(\frac{1}{\epsilon} + 2 \right) = \frac{d}{3\epsilon_0 A} \left(\frac{1+2\epsilon}{\epsilon} \right),$$

$$C = \left(\frac{3\epsilon}{2\epsilon+1} \right) \frac{\epsilon_0 A}{d}.$$

Since the capacitance without the dielectric is $C_0 = \epsilon_0 A/d$, we see that

$$C = \left(\frac{3\epsilon}{2\epsilon+1} \right) C_0.$$

Problem 2

A coaxial cable consists of two cylindrical conductors. The gap between the conductors is completely filled with silicon as in Fig.16a. The radius of the inner conductor is $a = 0.5$ cm, the radius of the outer one is $b = 1.75$ cm, and their length is $L = 15.0$ cm. Calculate the total resistance of the silicon when measured between the inner and outer conductors.

Reasoning: In this type of problem, we must divide the object whose resistance we are calculating into elements of infinitesimal thickness over which the area may be considered constant. We start by using the differential form of equation for resistance which is $dR = \rho dl/A$, where dR is the resistance of a section of silicon of thickness dl and area A . In this example, we take as our element a hollow cylinder of thickness dr and length L as in Fig.16b. Any current that passes between the inner and outer conductors must pass radially through such elements, and the area through which this

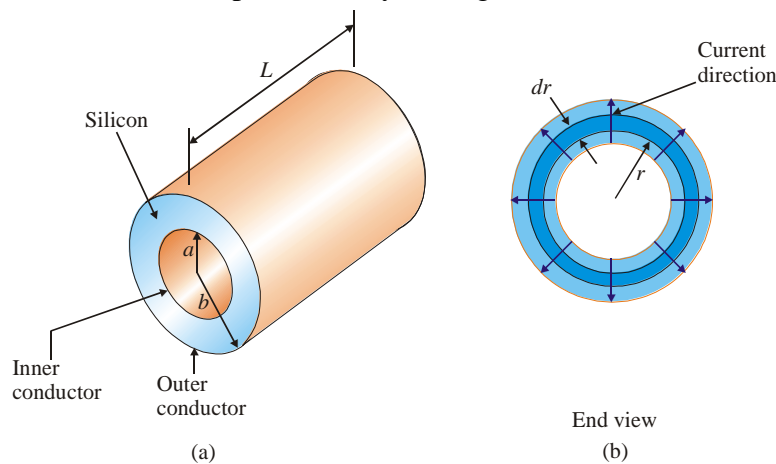

current passes is $A = 2\pi rL$. (This is the surface area of our hollow cylinder, neglecting the area of its ends.) Hence, we can write the resistance of our hollow cylinder as

$$dR = \frac{\rho}{2\pi rL} dr.$$

Figure 16.

Solution: Since we wish to know the total resistance of the silicon, we must integrate this expression over dr from $r = a$ to $r = b$:

$$R = \int_a^b dR = \frac{\rho}{2\pi L} \int_a^b \frac{dr}{r} = \frac{\rho}{2\pi L} \ln\left(\frac{b}{a}\right).$$

Substituting in the values given, and using $\rho = 640 \Omega \cdot \text{m}$ for silicon, we get

$$R = \frac{640 \Omega \cdot \text{m}}{2\pi(0.150 \text{ m})} \ln\left(\frac{1.75 \text{ cm}}{0.500 \text{ cm}}\right) = 851 \Omega.$$

Exercise: If a potential difference of 12.0 V is applied between the inner and outer conductors, calculate the total current that passes between them. **Answer:** 14.1 mA.

Problem 3.

A solid ball made of an insulator ($\epsilon = 1$) has been drilled along the diameter and air has been removed from the cavity. An electron is placed in the cavity. What is the magnitude of the positive charge that should be imparted to the ball if we want the ball to perform harmonic oscillations in the cavity with a given frequency ν_0 (the charge is assumed to be evenly distributed over the ball's volume)? Assume that the cross-sectional area A of the cavity is considerably smaller than πR^2 , with R the radius of the ball.

Solution: We must calculate the electric field strength inside the ball. Let us apply Gauss' law. Suppose that the volume density of the charge, ρ , is equal to $3Q/4\pi R^3$. We take an arbitrary point x distant from the center of the ball and draw a sphere of radius x centered at the ball's center O and passing through that point (Figure 17).

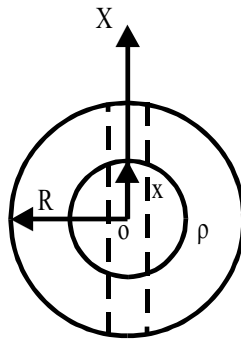

Figure 17.

The flux of vector \mathbf{E} out of the sphere is, in view of the symmetry of the field,

$$\Phi_E = E \cdot 4\pi x^2.$$

By Gauss' law,

$$E \cdot 4\pi x^2 = \frac{4\pi x^3 \rho}{3\epsilon_0},$$

whence

$$E = \frac{\rho}{3\epsilon_0} x.$$

Thus, the force acting on the electron is

$$F = \frac{\rho e}{3\epsilon_0} x.$$

From Newton's second law we get the differential equation of the electron's harmonic oscillations:

$$m_e \ddot{x} = -\frac{\rho e}{3\epsilon_0} x.$$

Consequently, the angular frequency ω_0 is equal to $\sqrt{\rho e / 3\epsilon_0 m_e}$. Since $\omega_0 = 2\pi\nu_0$, we can find the sought volume charge density,

$$\rho = 12\pi^2 \epsilon_0 \nu_0^2 m_e / e,$$

and the charge on the ball,

$$Q = \frac{4}{3} \pi R^3 \rho.$$

For $\nu_0 = 10^6 \text{ Hz} = 1 \text{ Mhz}$ and $R = 10^{-1} \text{ m}$ we have $\rho \approx 6 \cdot 10^{-9} \text{ C/m}^3$ and $Q \approx 2.4 \cdot 10^{-11} \text{ C}$.

Problem 4.

A sufficiently long, round cylinder made from a homogeneous and isotropic insulator with a known dielectric constant ϵ is placed in a homogeneous electric field \mathbf{E}_0 in such a manner that the cylinder's axis coincides with the direction of \mathbf{E}_0 (Figure 18). Determine the electric field strength near the cylinder (inside and outside).

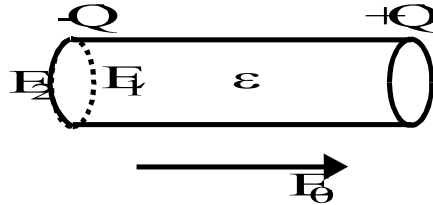

Figure 18.

Solution: Clearly, Gauss' method is useless here. Applying Gauss' law, we arrive at the trivial identity $D_1 = D_2$ expressing the continuity of the normal components of the electric displacement vector. Let us apply the superposition method. By E_1 we denote the electric field strength inside the cylinder and by E_2 the electric field strength outside. Owing to the polarization of the insulator, bound charges $-Q'$ and $+Q'$ gather on the bases of the cylinder with a density σ' . The resulting electric fields \mathbf{E}_1 and \mathbf{E}_2 are the vector sums of \mathbf{E}_0 and the electric fields generated by the bound charges $-Q'$ and $+Q'$. Let us now discuss the meaning of the words "sufficiently long cylinder". The cylinder considered here is so long that the field generated, say, by charge $+Q'$ is weak in the vicinity of charge $-Q'$ and can be neglected in comparison to the field generated by $-Q'$ in that vicinity. The same is true of the field generated by $-Q'$ in the vicinity of charge $+Q'$. Thus,

$$E_1 = E_0 - E', \quad E_2 = E_0 + E',$$

where E' is the electric field strength generated by $-Q'$ (or $+Q'$). Let us find E' .

E' is the field of a uniformly charged disk. The projection of the elementary electric field vector on the disk's axis generated by a thin ring (the X axis is directed along the axis of the disk):

$$dE_x = \frac{xdQ}{4\pi\epsilon_0(r^2 + x^2)^{3/2}} = \frac{2\pi r\sigma'xdr}{4\pi\epsilon_0(r^2 + x^2)^{3/2}}.$$

Integration with respect to r from zero to R (the radius of the disk) yields the electric field strength generated by the disk (or the field of the bound charge $-Q'$):

$$E' = E_x = \int_0^R \frac{r\sigma'xdr}{2\epsilon_0(r^2 + x^2)^{3/2}} = \frac{\sigma'}{2\epsilon_0} \left[1 - \frac{x}{\sqrt{x^2 + R^2}} \right].$$

From this it follows, for one, that E' is roughly zero when x is very large. This completes the justification for using the term "sufficiently long cylinder".

Near the base of the cylinder $x \approx 0$ and

$$E' = \sigma' / (2\epsilon_0).$$

We obtain

$$E_1 = E_0 - \frac{\epsilon_0(\epsilon_0 - 1)E_1}{2\epsilon_0}$$

and, hence,

$$E_1 = \frac{2}{1 + \epsilon} E_0.$$

Then, it yields

$$\sigma' = 2\epsilon_0 \frac{\epsilon - 1}{1 + \epsilon} E_0.$$

We obtain

$$E' = \frac{\epsilon - 1}{1 + \epsilon} E_0.$$

Hence,

$$E_2 = \frac{2\epsilon}{1 + \epsilon} E_0.$$

Problem 6.

Determine the capacitance of a section of unit length of a two-wire line.

Solution: The formulation of the problem is incomplete. Let us idealize the problem. We assume that the linear charge density (charge per unit length) on one wire is $-\tau$ and on the other, $+\tau$. We also assume that all other bodies are so far from the line that their effect on the electric field in the space between the wires can be ignored. Finally, we assume that the wires have the same radius $r \ll l$, where l is the distance between the wires. Thus, the physical system consists of three objects: two infinitely long thin, straight parallel wires uniformly charged with linear charge densities $-\tau$ and $+\tau$ and the electric field generated by these charges. We wish to find the capacitance of a segment of unit length of such a system.

The problem is linked to the basic problem of field theory. Let us calculate the field strength between the wires at an arbitrary point A that is positioned at a distance x from the left wire (Figure 19).

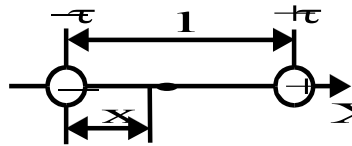

Figure 19.

Employing the superposition principle and the formula for the strength of the field generated by an infinitely long straight, uniformly charged string, we get

$$E = \frac{\tau}{2\pi\epsilon_0 x} + \frac{\tau}{2\pi\epsilon_0 (l - x)}.$$

Allowing for the relationship between field strength and potential, we get

$$\varphi = -\int E dx = -\frac{\tau}{2\pi\epsilon_0} [\ln x - \ln(l - x)] + c,$$

where c is an arbitrary constant. This gives us the potentials of the left and right wires:

$$\varphi_1 = -\frac{\tau}{2\pi\epsilon_0} [\ln r - \ln(l - r)] + c,$$

$$\varphi_2 = -\frac{\tau}{2\pi\epsilon_0} [\ln(l - r) - \ln r] + c.$$

Next we find the potential difference between the wires:

$$\Delta\varphi = \varphi_1 - \varphi_2 = \frac{\tau}{\pi\epsilon_0} \ln \frac{1-r}{r}.$$

Since $r \ll 1$ by hypothesis, we have

$$\Delta\varphi \cong \frac{\tau}{\pi\epsilon_0} \ln \frac{1}{r}.$$

Employing relationship $C = Q/\varphi$, we can determine the capacitance of a section of unit length of a two-wire line:

$$C = \frac{\tau}{\Delta\varphi} = \frac{\pi\epsilon_0}{\ln(1/r)}.$$

3. Steady Electric Current

3.1 Electric Current

If a total charge other than zero is carried through a surface, an *electric current* (or simply *current*) is said to flow through this surface. For a current to flow, the given medium must contain charged particles that can move in the limits of the medium. Such particles are called *current carriers* (electrons, ions, or even macroscopic particles). A current is produced if there is an electric field inside the body. The mean value of the velocity of thermal motion is zero, thus when the electric field acts upon the current carriers, they acquire the additional velocity \mathbf{U} coinciding for the positive carriers with the field direction and opposite to that for the negative carriers. If the charge dq is carried through a surface during the time dt , it is said the *current strength* (or simply the *current*)

$$I = \frac{dq}{dt} \quad (3.1)$$

is established. The transfer of a negative charge in one direction is equivalent to the transfer of a positive charge of the same magnitude in the opposite direction. Thus, if a current is produced by carriers of both signs, we can write

$$I = \frac{dq^+}{dt} + \left| \frac{dq^-}{dt} \right|. \quad (3.2)$$

The direction of motion of the positive carriers has been historically assumed to be the direction of a current.

A current (I) is a scalar quantity and it can be distributed non-uniformly over the relevant surface. In order to characterize this distribution, a vector quantity \mathbf{j} , called the *current density* is introduced

$$dI = \mathbf{j} \cdot d\mathbf{S}. \quad (3.3)$$

Thus, the current flowing through the elementary surface characterized by the surface vector $d\mathbf{S}$ can be expressed as a scalar product of \mathbf{j} and $d\mathbf{S}$.

Let us assume that the space densities of positive and negative charges are, correspondingly, n^+ and n^- . If the carriers acquire the average velocities \mathbf{U}^+ and \mathbf{U}^- , then the current density can be expressed as:

$$\mathbf{j} = e^+ n^+ \mathbf{U}^+ + e^- n^- \mathbf{U}^-. \quad (3.4)$$

In equation (3.4) both addends are of the same direction: the vector \mathbf{U}^- is directed oppositely to the vector \mathbf{j} , when it is multiplied by the negative scalar e^- , we get a vector

of the same direction as \mathbf{j} . The products e^+n^+ and e^-n^- give the charge densities of positive (ρ^+) and negative (ρ^-) carriers. Hence, equation (3.4) can be written in the form

$$\mathbf{j} = \rho^+ \mathbf{U}^+ + \rho^- \mathbf{U}^- . \quad (3.5)$$

A current that does not change with time is called *steady* (do not confuse with a direct current whose direction is constant, but whose magnitude may vary). For a steady current

$$I = \frac{q}{t} . \quad (3.6)$$

where q is the charge carried through the surface being considered during the finite time t . In the SI, the unit of current is the *ampere* (A). The unit of charge, the *Coulomb* (C), is defined as the charge carried in one second through the cross section of a conductor at a current of one ampere.

3.2 Continuity Equation

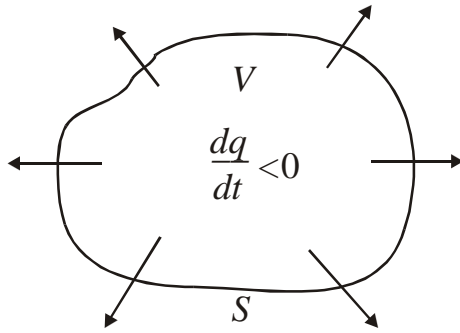

Figure 3.1

Let us consider a closed surface S (see Figure 3.1) in a conductive medium.

The integral $\oint_S \mathbf{j} dS$ is a charge emerging in a unit time from the volume V enclosed by the surface S . According to the charge conservation law, this quantity must equal to the rate of diminishing of the charge q contained in the given volume

$$\oint_S \mathbf{j} dS = - \frac{dq}{dt} . \quad (3.7)$$

The surface integral in the left-hand part of equation (3.7) can be transformed in the integral from $\text{div} \mathbf{j}$ over the volume V , and on the other hand, obviously $q = \int \rho dV$. So, we have

$$\int_V \text{div} \mathbf{j} \cdot dV = - \int_V \frac{\partial \rho}{\partial t} dV \quad (3.8)$$

(the space coordinates and time are independent quantities). Equation (3.8) hold for an arbitrary volume. Thus, it follows:

$$\text{div} \mathbf{j} = - \frac{\partial \rho}{\partial t} \quad (3.9)$$

Equation (3.9) is known to be the *continuity equation*. It expresses the charge conservation law in the differential form. For a steady current, all the quantities do not depend on time. Hence, for a steady current we have

$$\text{div} \mathbf{j} = 0 . \quad (3.10)$$

Thus, for a steady current, the vector \mathbf{j} has no sources. Hence, the lines of steady current are always closed. Accordingly, $\oint_S \mathbf{j} dS$ equals zero.

3.3 Electromotive Force

In order to maintain an electric current in a closed circuit, it is necessary to have (in addition to sections on which the positive carriers travel in the direction of a decrease in the potential φ) the sections on which the positive charges are carried in the direction of a growth in φ , i.e. against the forces of the electrostatic field (see Figure 3.2)

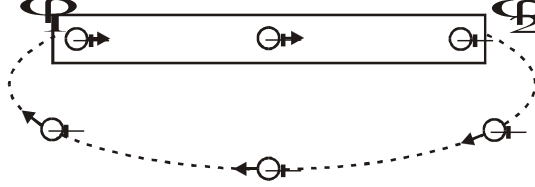

Figure 3.2

Motion of the carriers on these sections can be produced only by the forces of a non-electrostatic origin, called *extraneous forces*. These forces may be due to chemical processes, the diffusion of the current carriers in a non-uniform medium, to electric (but not electrostatic) fields set up by magnetic fields varying with time, and so on. The quantity equal to the work done by the extraneous forces on a unit positive charge (q) is called the *electromotive force (e.m.f.)* E , i.e.

$$E = \frac{A}{q} \quad (3.11)$$

(E is measured in the same units as φ). The extraneous force \mathbf{F}_{extr} acting on the charge q can be written as follows:

$$\mathbf{F}_{\text{extr}} = \mathbf{E}^* q. \quad (3.12)$$

The vector quantity \mathbf{E}^* is called the *strength of the extraneous force field*. The integral from the scalar product $\mathbf{E}^* d\mathbf{l}$ calculated for a closed circuit gives the e.m.f. acting in the circuit. Thus,

$$E = \oint \mathbf{E}^* d\mathbf{l}. \quad (3.13)$$

In other words, the e.m.f. acting in a closed circuit can be determined as the circulation of the strength vector of the extraneous forces. In addition to extraneous forces, a charge experiences the forces produced by an electrostatic field $\mathbf{F}_E = q\mathbf{E}$. Hence, the resultant force acting at each point of a circuit on the charge q is

$$\mathbf{F} = \mathbf{F}_E + \mathbf{F}_{\text{extr}} = q(\mathbf{E} + \mathbf{E}^*) \quad (3.14)$$

The work done by this force on the charge q on circuit section 1-2 is determined by the expression

$$A_{12} = q \int_1^2 \mathbf{E} d\mathbf{l} + q \int_1^2 \mathbf{E}^* d\mathbf{l} = q(\varphi_1 - \varphi_2) + qE_{12}, \quad (3.15)$$

where E_{12} is the *e.m.f. acting on the given section*. The quantity numerically equal to the work done by electrostatic and extraneous forces in moving a unit positive charge is defined as the *voltage drop* or simply the *voltage* U on the given section of the circuit. In accordance with equation (3.15) we can write:

$$U_{12} = \varphi_1 - \varphi_2 + E_{12}. \quad (3.16)$$

A section of a circuit on which no extraneous forces act is called *homogeneous*. A section on which the current carriers experience extraneous forces is called *inhomogeneous*. For a homogeneous circuit

$$U_{12} = \varphi_1 - \varphi_2, \quad (3.17)$$

i.e. the voltage coincides with the potential difference across the ends of the section.

3.4 Ohm's Law. Resistance of Conductors

This experimentally established law can be formulated as follows: the current flowing in a homogeneous metal conductor is proportional to the voltage drop in the conductor

$$I = \frac{U}{R}. \quad (3.18)$$

The scalar quantity R is called the **electrical resistance** of a conductor. The SI unit of resistance is the ohm (Ω) equal to the resistance of a conductor in which a current of 1A flows at a voltage of 1V. Experiments show that for a homogeneous cylindrical conductor

$$R = \rho \frac{l}{S}, \quad (3.19)$$

where l is the length of the conductor, S is the cross section of the conductor, ρ is the coefficient depending on the properties of the material and called the **resistivity** of the substance. It is easy to see that ρ is measured in ohm-meters ($\Omega \cdot m$). It should be noted that ρ depends also on the temperature of a conductor:

$$\rho = \rho_0(1 + \alpha t), \quad (3.20)$$

where α is a temperature resistance coefficient.

To establish the relation between the vector \mathbf{j} and \mathbf{E} , let us mentally separate an elementary cylindrical volume with generatrices parallel to the vector \mathbf{j} and \mathbf{E} (see Figure 3.3)

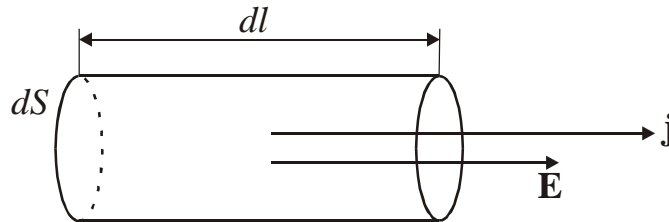

Figure 3.3

Obviously, $j dS = \frac{E dl}{\rho dl}$, or $j = \frac{1}{\rho} E$. Having in mind that the vectors \mathbf{j} and \mathbf{E} are

collinear, we get

$$\mathbf{j} = \frac{1}{\rho} \mathbf{E} = \sigma \mathbf{E}. \quad (3.21)$$

The Equation (3.21) expresses Ohm's law in the differential form. The quantity σ is called the **conductivity** of a substance and is measured in **siemens per meter** (S/m). (The unit that is reciprocal of the ohm is called the **siemens**).

3.5 Ohm's Law for an Inhomogeneous Circuit Section

The extraneous forces act on the current carriers in the same way as the electrostatic ones. So, in the case of an inhomogeneous circuit section, the strength of the extraneous force field must be added in equation (3.21)

$$\mathbf{j} = \sigma(\mathbf{E} + \mathbf{E}^*) \quad (3.22)$$

This equation expresses Ohm's law for an inhomogeneous section of a circuit in the differential form. In order to pass over from Ohm's law in the differential form to its

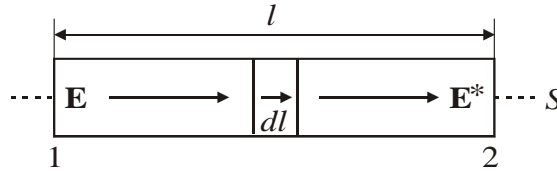

Figure 3.4

integral one, let us consider an inhomogeneous section of a circuit (see Figure 3.4). According to equation (3.22) we can write

$$jl = \sigma(E_l + E_l^*). \quad (3.23)$$

substituting l/S for jl and $1/\rho$ for σ we get:

$$I \cdot \frac{\rho}{S} = E_l + E_l^*. \quad (3.24)$$

Multiplication of this equation by dl and integration along the length of the section yield:

$$I \int_1^2 \rho \frac{dl}{S} = \int_1^2 E_l dl + \int_1^2 E_l^* dl. \quad (3.25)$$

The quantity $\rho \frac{dl}{S}$ is the resistance of the section of the length dl , hence the integral of this quantity is the resistance R of the total circuit section. The first integral in the right-hand side gives $\varphi_1 - \varphi_2$, and the second integral equals e.m.f. E_{12} acting on the section. Thus, we get

$$IR = \varphi_1 - \varphi_2 + E_{12} \quad (3.26)$$

The e.m.f. E_{12} , like the current I , is a scalar quantity. When the e.m.f. facilitates the motion of the positive current carriers in the selected direction (in Figure 3.4, it is direction 1-2), we have $E_{12} > 0$. If the e.m.f. inhibits the motion of the positive carriers in the given direction, $E_{12} < 0$.

Equation (3.26) written in the form

$$I = \frac{\varphi_1 - \varphi_2 + E_{12}}{R} \quad (3.27)$$

is known to be called Ohm's law for an inhomogeneous circuit section. Assuming that $\varphi_1 = \varphi_2$, we get the equation of Ohm's law for a closed circuit:

$$I = \frac{E}{R}, \quad (3.28)$$

where E is the e.m.f. acting in the circuit, R is the total resistance of the entire circuit.

3.6 Kirchoff's Rules

The calculation of multi-loop circuits is considerably simplified if two Kirchoff's rules are used. The first of them relates to the circuit junctions. A *junction* is defined as a point where three or more conductors meet (see Figure 3.5).

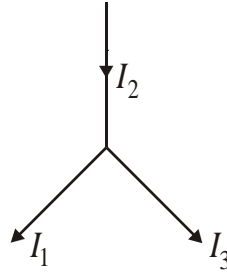

Figure 3.5

A current flowing toward a junction is considered to have one sign (plus or minus), and a current flowing out of a junction is considered to have the opposite sign (minus or plus).

Kirchoff's first rule, also called the *junction rule*, is formulated as follows: the algebraic sum of all the currents coming into a junction equals zero:

$$\sum_{(k)} I_k = 0. \quad (3.29)$$

This rule follows from the continuity equation, i.e. from the charge conservation law.

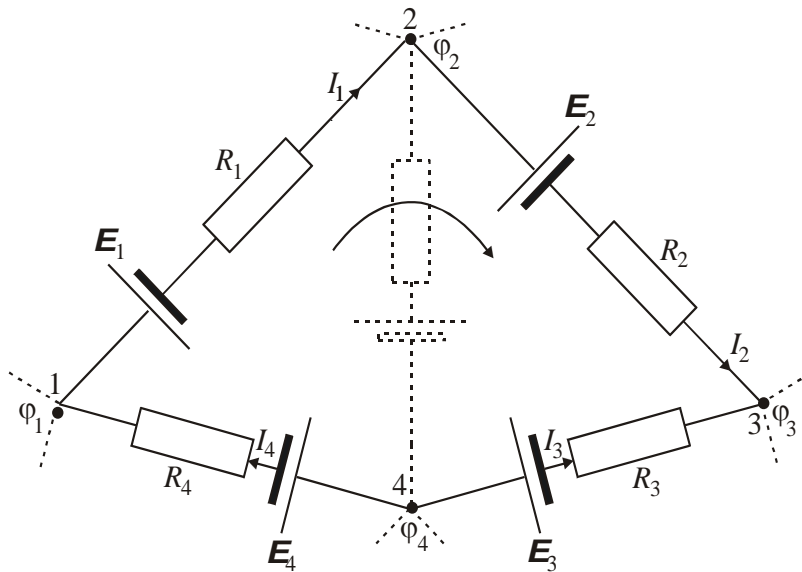

Figure 3.6

Equation (3.29) can be written for each of the N junctions of a circuit. Only $N-1$ equations will be independent, however, whereas the N -th one will be a corollary of them.

The second rule relates to any closed loop separated from a multiloop circuit (see Figure (3.6). For a loop 1-2-3-4-1 we can write according with Ohm's law for an inhomogeneous branches of the loop, the following equations:

$$\begin{aligned}
I_1 R_1 &= \varphi_1 - \varphi_2 + \mathbf{E}_1 \\
I_2 R_2 &= \varphi_2 - \varphi_3 + \mathbf{E}_2 \\
I_3 R_3 &= \varphi_3 - \varphi_4 + \mathbf{E}_3 \\
I_4 R_4 &= \varphi_4 - \varphi_1 + \mathbf{E}_4
\end{aligned}$$

When these expressions are summed, the potentials are cancelled, and we get

$$\sum I_k R_k = \sum \mathbf{E}_k \quad (3.30)$$

Equation (3.30) expresses *Kirchhoff's second rule*, also called the *loop rule*. Equation (3.30) can be written for all the closed loops that can be separated mentally in a given multiloop circuit. Only the equations for the loop that cannot be obtained by the superposition of the loops on one another will be independent, however.

3.7 Power of a Current

The electrostatic and extraneous forces acting on the given section of an electric circuit do the work

$$A = Uq = UIt. \quad (3.31)$$

Dividing equation (3.31) by the time t during which it is done we get the *power* of the current

$$P = UI = (\varphi_1 - \varphi_2)I + \mathbf{E}_{12}I. \quad (3.32)$$

The ratio of the power ΔP developed by a current in the volume ΔV of a conductor to the magnitude of this volume is called the *unit power of the current* P_U corresponding to the given point of the conductor

$$P_U = \frac{\Delta P}{\Delta V}. \quad (3.33)$$

An expression for the unit power can be obtained from the following considerations. The force $e(\mathbf{E} + \mathbf{E}^*)$ develops a power of

$$P' = e(\mathbf{E} + \mathbf{E}^*)\mathbf{U}, \quad (3.34)$$

where \mathbf{U} is the average velocity of the carriers (the thermal velocity must be taken into consideration!).

Obviously, the power ΔP developed in the volume ΔV can be obtained by multiplying P' by the number of current carriers in this volume, i.e. by $n\Delta V$ (n is the number of carriers per unit volume). Thus,

$$\Delta P = e(\mathbf{E} + \mathbf{E}^*)Un\Delta V = \mathbf{j}(\mathbf{E} + \mathbf{E}^*)\Delta V. \quad (3.35)$$

Hence,

$$P_U = \mathbf{j}(\mathbf{E} + \mathbf{E}^*). \quad (3.36)$$

This expression is a differential form of the integral equation (3.32).

3.8 The Joule-Lenz Law

When a conductor is stationary and no chemical transformations occur in it, the work done by current increases the internal energy of the conductor, and as a result the latter gets heated, i.e. the heat

$$Q = UIt \quad (3.37)$$

is liberated. Substituting RI for U , we get

$$Q = RI^2 t. \quad (3.38)$$

This Equation is known to be called the **Joule-Lenz Law**. Equation (3.38) can be transformed in a differential form (see Figure 3.3). For an elementary cylindrical volume, we can write

$$dQ = RI^2 dt = \frac{\rho dl}{dS} (jdS)^2 dt = \rho j^2 dV dt. \quad (3.39)$$

Dividing equation (3.39) by dV and dt , we amount of heat liberated in unit volume per unit time:

$$Q_U = \rho \cdot j^2. \quad (3.40)$$

The quantity Q_U is called the **unit thermal power of a current**.

Equation (3.40) is a differential form of the Joule-Lenz law. It can also be obtained from equation (3.36). Substituting $\mathbf{j}/\sigma = \rho\mathbf{j}$ for $\mathbf{E} + \mathbf{E}^*$ in Equation (3.36) we arrive at the expression

$$P_U = \rho \cdot j^2 \quad (3.41)$$

that coincides with equation (3.40).

It must be noted that Joule and Lenz established their law for a homogeneous circuit section. As follows from what has been said in the present section, however, Equations (3.37) and (3.40) also hold for an inhomogeneous section provided that the extraneous forces acting in it have a non-chemical origin.

Examples

Problem 9

Find the currents I_1 , I_2 and I_3 in the circuit shown in Figure 9.

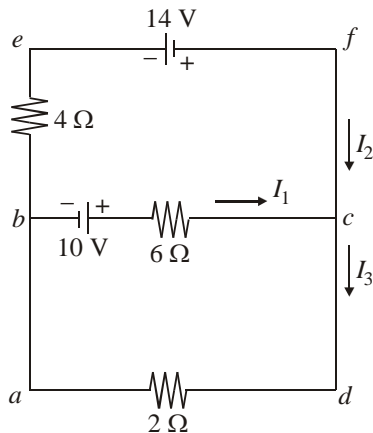

Figure 9. A circuit containing three loops.

Reasoning We choose the directions of the currents as in Fig.9. Applying Kirchhoff's first rule to junction c gives

$$I_1 + I_2 = I_3. \quad (1)$$

There are three loops in the circuit, $abcda$, $befcb$, and $ae fda$ (the outer loop). Therefore, we need only two loop equations to determine the unknown currents. The third loop equation would give no new information. Applying Kirchhoff's second rule to loops $abcda$ and $befcb$ and traversing these loops in the clockwise direction, we obtain the expressions

Loop $abcda$:

$$10V - (6\Omega)I_1 - (2\Omega)I_3 = 0 \quad (2)$$

Loop $befcb$:

$$-14V - 10V + (6\Omega)I_1 - (4\Omega)I_2 = 0 \quad (3)$$

Note that in loop $befcb$, a positive sign is obtained when traversing the $6\text{-}\Omega$ resistor because the direction of the path is opposite the direction of I_1 . A third loop equation for $ae fda$ gives $-14 = 2I_3 + 4I_2$, which is just the sum of (2) and (3).

Solution Expressions (1), (2), and (3) represent three independent equations with three unknowns. We can solve the problem as follows: Substituting (1) into (2) gives

$$10 - 6I_1 - 2(I_1 - I_2) = 0;$$

$$10 = 8I_1 + 2I_2. \quad (4)$$

Dividing each term in (3) by 2 and rearranging the equation gives

$$-12 = -3I_1 + 2I_2. \quad (5)$$

Subtracting (5) from (4) eliminates I_2 , giving

$$22 = 11I_1;$$

$$I_1 = 2A.$$

Using this value of I_1 in (5) gives a value for I_2 :

$$2I_2 = 3I_1 - 12 = 3(2) - 12 = -6;$$

$$I_2 = -3A.$$

Finally, $I_3 = I_1 + I_2 = -1A$. Hence, the currents have the values

$$I_1 = 2A \quad I_2 = -3A \quad I_3 = -1A$$

The fact that I_2 and I_3 are both negative indicates only that we chose the wrong direction for these currents. However, the numerical values are correct.

Exercise: Find the potential difference between points b and c .

Answer: $V_b - V_c = 2V$.

4. Magnetic Field

4.1. Biot-Savart's law. Ampere's law.

In beginning of 19th century, H.Oersted, the Danish scientist, discovered experimentally that if a conductor carries an electric current \vec{I} , it influences the magnetic pointer situated near it in a similar way as an ordinary magnet. Further experiments showed that two long straight conductors carrying the currents are attracted if the directions of the currents coincide, and are repulsed if the directions of the currents are opposite (see, Figure 5.1[a]).

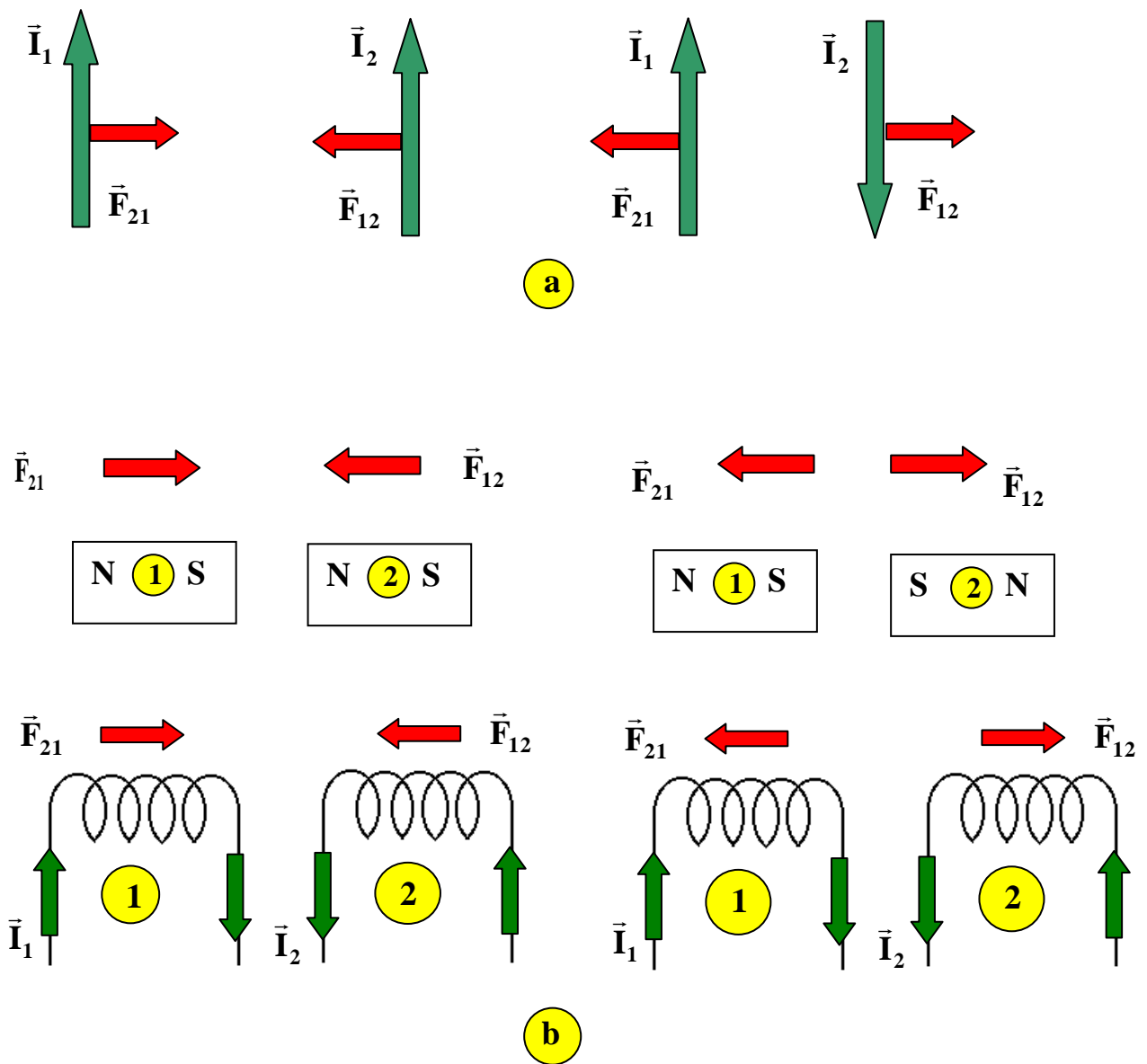

Figure 5.1

It is well known from experiments that two permanent magnets are attracted or repulsed if they are directed to each other by similar or opposite poles (northern or southern ones). Two solenoids carrying the currents are interacting in the same way as two permanent magnets, and are attracted or repulsed depending on the currents mutual directions (Figure 5.1[a] and Figure 5.1[b]). One says that an interaction of the conductors occurs due to magnetic media, which is called the magnetic field. Thus, the magnetic field causes the force, which influences the conductor carrying a current and magnetizes the bodies. Since the current is the directed motion of charged particles, the magnetic field causes the force, which influences the motion of charged particles and bodies.

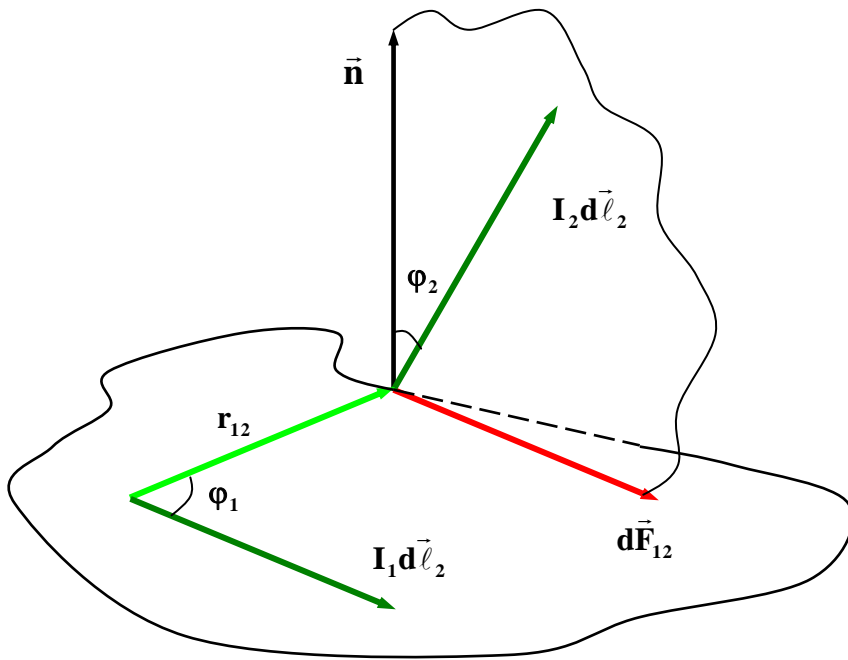

Figure 5.2

In order to describe the (magnetic) interaction of conductors carrying the currents, consider the electric current element $I d\vec{l}$, which is a vector and is defined as the product of the electric current strength I and the length element $d\vec{l}$ of a conductor. Here, $d\vec{l}$ is directed along a current. Let the elements of two currents be situated in a space as shown in Figure 5.2.

In this case the elemental force $d\vec{F}_{12}$, which experiences in a vacuum the current element $d\vec{l}_2$ due to magnetic field produced by the current element $d\vec{l}_1$, can be written (in the SI system) in a form:

$$d\vec{F}_{12} = \frac{\mu_0}{4\pi} \cdot \frac{I_1 I_2}{r_{12}^3} \cdot [d\vec{l}_2 [d\vec{l}_1 \vec{r}_{12}]] . \quad (5.1a)$$

The modulus of this force is

$$|d\vec{F}_{12}| = \frac{\mu_0}{4\pi} \cdot \frac{I_1 dl_1 I_2 dl_2 \sin(\varphi_1) \sin(\varphi_2)}{r_{12}^2} . \quad (5.1b)$$

Here, \vec{r}_{12} is a vector directed from the current element $I_1 d\vec{l}_1$ to the current element $I_2 d\vec{l}_2$ and \vec{n} is the unit vector directed perpendicular to the plane in which the element $I_1 d\vec{l}_1$ lies, and $\mu_0 = 4\pi \cdot 10^{-7} \text{ H / A}^2$ is the magnetic constant. Equations (5.1a – 5.1.b) are two mathematical forms of Ampere’s law of magnetic interaction in a vacuum between the conductors carrying the currents. The force characteristic of the magnetic field is the vector of magnetic induction \vec{B} . Its numerical value equals to the limit of relation of the elemental force $d\vec{F}$, which is experienced by an elemental current due to magnetic field, to the absolute value of elemental current $|Id\vec{l}|$:

$$\vec{B} = \lim_{dl \rightarrow 0} \frac{d\vec{F}}{|Id\vec{l}|} .$$

The vector \vec{B} is directed perpendicularly to the conductor element and to the direction of the force by which the magnetic field influences this element. The magnetic induction is measured in SI system in Teslas, $[B] = T = N / (A \cdot m)$. In the Gauss’s system a magnetic induction is measured in Gausses: $[B] = G = 10^{-4} T$.

For the graphic representation of the magnetic field it is convenient to use *the force lines* of magnetic induction \vec{B} . The tangent to this line in every point coincides with the direction of the \vec{B} vector in that point. The force lines of magnetic induction \vec{B} are always closed. For example, the force lines of rectilinear conductor carrying a current are the circles in a plane perpendicular to a current. The \vec{B} force lines inside a solenoid (or inside a long cylindrical coil) are parallel to each other (see, Figure 5.3).

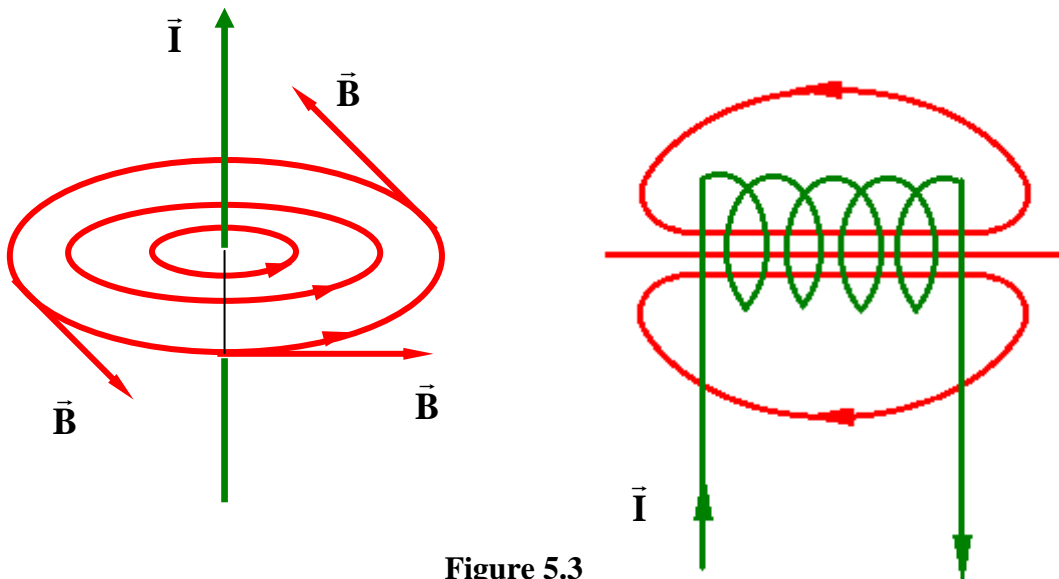

Figure 5.3

The magnetic field is called uniform if the \vec{B} vector is the same in every point of the field, i.e. these vectors are parallel and are drawn with the same density. An example of the uniform magnetic field is the field inside a long solenoid (Figure 5.3). The magnetic field is non-uniform if the field \vec{B} taken at different points of the field is different, i.e. the force lines are not parallel and are drawn with different density. An example of a non-uniform magnetic field is the magnetic field of the rectilinear conductor carrying a current (Fig.5.3b).

The direction of the force line of magnetic induction \vec{B} is easy to determine by the use of the so called **right-hand screw rule** which reads: if one rotates the screw in a current direction, the direction of a screw handle rotation shows the directions of the magnetic induction force lines.

The magnitude and direction of the magnetic induction vector $d\vec{B}$ at arbitrary point O of magnetic field, generated in a vacuum by the current element $I d\vec{l}$, is determined by **Biot and Savart law**:

$$d\vec{B} = \frac{\mu_0}{4\pi} \cdot \frac{I [d\vec{l} \vec{r}]}{r^3}; \quad (5.3)$$

$$dB = \frac{\mu_0}{4\pi} \cdot \frac{Idl \sin \varphi}{r^2}.$$

Here, \vec{r} is the radius-vector drawn from an element of a current to the point where the magnetic field is measured, and φ is an angle between the vectors $d\vec{l}$ and \vec{r} . The \vec{B} vector is perpendicular to a plane formed by the vectors $d\vec{l}$ and \vec{r} , and its direction in a space is determined by the right-hand screw rule: the screw handle rotates from $d\vec{l}$ to \vec{r} by passing the minimal angle, while the screw body indicates the $d\vec{B}$ direction (see, Figure 5.4).

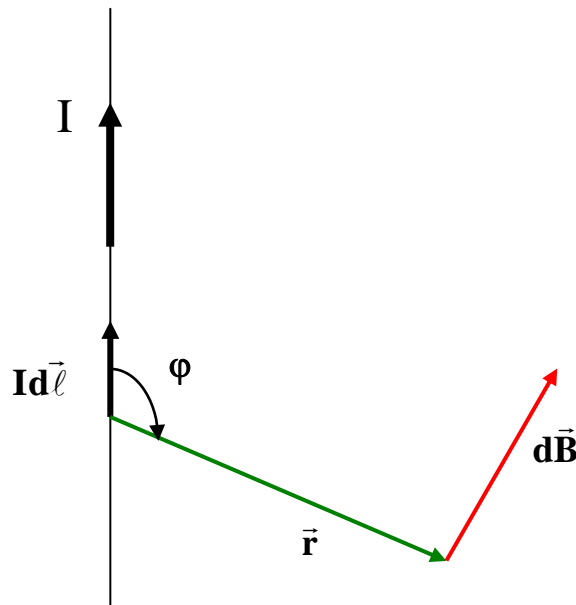

Figure 5.4

If there are few conductors carrying different electric currents, then the resulting magnetic field generated by the system of currents is determined according to the fields superposition principle. As a result, the magnetic field \vec{B} generated by electric currents I_1, I_2, \dots, I_n equals to a vector sum of magnetic fields generated by each current I_k separately, i.e. $\vec{B} = \sum_{i=1}^n \vec{B}_i$.

The superposition principle of magnetic fields allows to find the magnetic field induction \vec{B} generated by a conductor of finite length carrying a current I , at arbitrary point of a magnetic field:

$$\vec{B} = \int_l d\vec{B} = \frac{\mu_0}{4\pi} \cdot \int_l I \sin(\varphi) d\varphi \quad . \quad (5.4)$$

Using this equation, one obtains easily the magnetic field generated by a conductor of specific shape carrying a current I .

a) Straight current (wire) carrying conductor (Figure 5.5[a])

$$B = \frac{\mu_0}{4\pi} \cdot \frac{I}{r} (\cos \varphi_1 - \cos \varphi_2); \quad (5.5)$$

Here, r is the length of the perpendicular drawn from an observation point to a straight line, which coincides with a current.

b) Infinite straight current carrying conductor (Figure 5.5[b]):

$$B = \frac{\mu_0}{4\pi} \cdot \frac{2I}{r} = \frac{\mu_0}{2\pi} \cdot \frac{I}{r} \quad . \quad (5.6)$$

Here, r is the distance between a wire and observation point.

c) In a center of a circular current loop (Figure 5.5[c]):

$$B = \frac{\mu_0 I}{2R}; \quad (5.7)$$

Here, R is a radius of the loop.

d) On the axis of the circular current loop (Figure 5.5[d])

$$B = \frac{\mu_0}{2} \cdot \frac{IR^2}{(R^2 + r^2)^{3/2}}; \quad (5.8)$$

Here, R is a radius of the loop while r is a distance between a loop center and observation point.

e) In a center of the square current loop (Figure 5.5[e]):

$$B = \frac{\mu_0}{4\pi} \cdot \frac{8\sqrt{a^2 + b^2}}{ab} \quad . \quad (5.9)$$

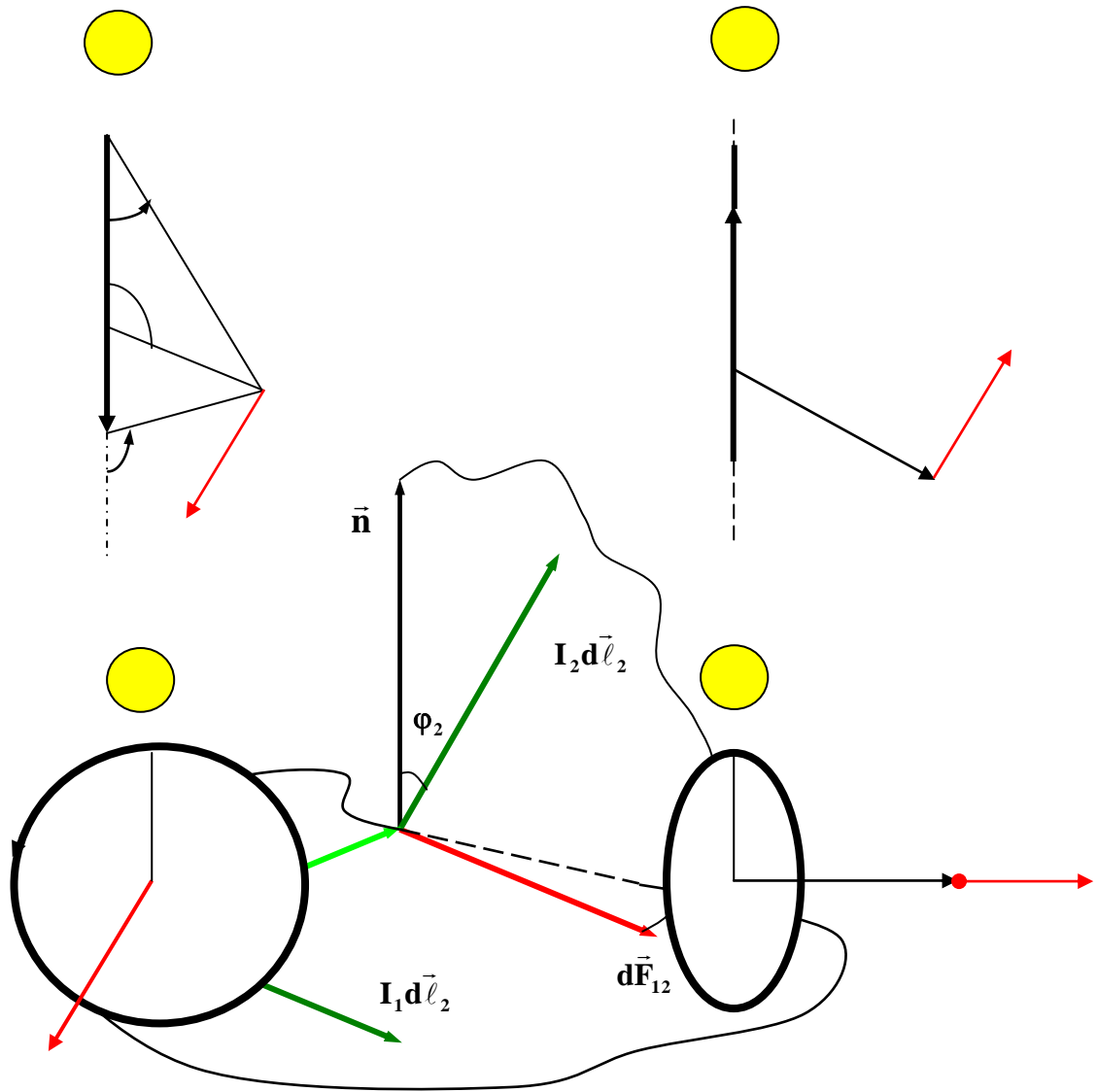

Figure 5. 

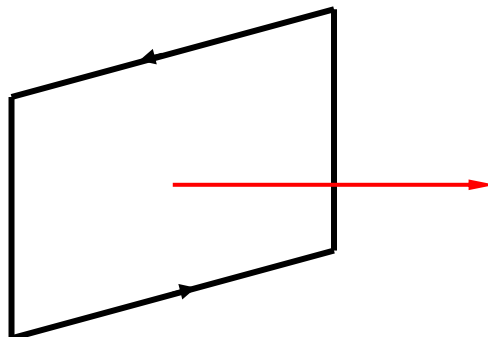

Figure 5.5

If the conductor (wire) carrying a current is a closed contour (loop) (e.g., circle or rectangle), one introduces the vector $\vec{P}_m = I\vec{S} = IS\vec{n}$, which is called the **vector of magnetic moment of a current**. Its magnitude equals a product of the current I and a surface S , closed by a contour. The vector \vec{P}_m is directed parallel to the normal vector \vec{n} to a contour plane, so that if seeing from the end of the vector \vec{P}_m , the current flows counter-wise. Using the definition of a magnetic moment vector, the Equation (5.7) and Equation (5.8) can be rewritten in a form:

$$\vec{B} = \frac{\mu_0}{2\pi} \cdot \frac{\vec{P}_m}{R^3}; \quad \vec{B} = \frac{\mu_0}{2\pi} \cdot \frac{\vec{P}_m}{(R^2 + r^2)^{3/2}}. \quad (5.10)$$

Thus, a conductor carrying a current produces the magnetic field around itself. Similarly, one can suppose that a moving charge produces the magnetic field around itself. Indeed, the charge q moving with a velocity \vec{V} ($|\vec{V}| = v \ll c$) in a vacuum, generates the magnetic induction \vec{B}

$$\vec{B} = \frac{\mu_0}{4\pi} \cdot \frac{q}{r^3} [\vec{V}\vec{r}]. \quad (5.11)$$

Here, \vec{r} is the radius-vector drawn from the charge position to the observation point A (Figure 5.6).

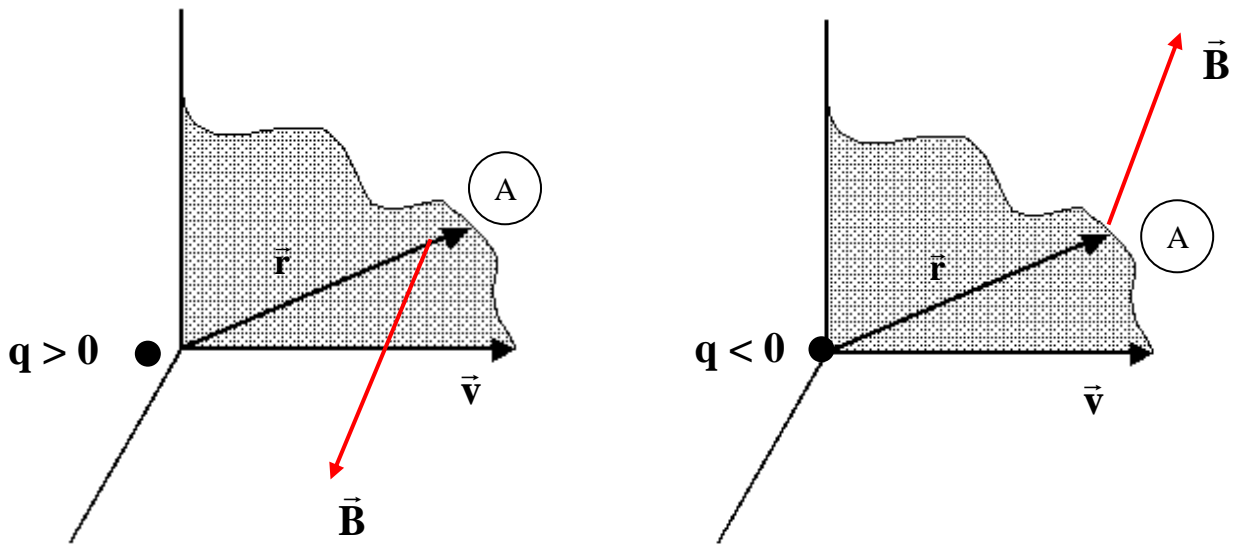

Figure 5.6.

The magnetic field of a moving charge is variable (time-dependent), since both direction and magnitude of \vec{r} are changing upon a charge motion, even if its velocity $\vec{V} = \text{const}$. During a charge motion, its electric field $\vec{E} = q\vec{r} / 4\pi r^3$ moves too, therefore the equation (5.11) can be rewritten in a form:

$$\vec{B} = \mu_0 [\vec{V}_E \vec{E}]. \quad (5.12)$$

The Equation (5.12) allows the conclusion that any electric field moving at velocity \vec{V}_E produces a magnetic field described by equation (5.12).

If one places the conductor (wire) of the length dl carrying a current I into a magnetic field characterized by magnetic induction \vec{B} , there arises a force $d\vec{F}_A$, which acts on the conductor. This force is called **Ampere's force** and is determined by the following equations which are **Ampere's law**:

$$\begin{aligned} d\vec{F}_A &= I [d\vec{l} \vec{B}] \\ dF_A &= Idl \cdot B \sin(d\vec{l} \vec{B}) \end{aligned}$$

In particular, if $d\vec{l} \perp \vec{B}$, the direction of Ampere's force is defined by **the left-hand rule** which reads: the palm of the left hand is situated so that the magnetic induction vector \vec{B} comes into the palm, the four fingers indicate the direction of the current, and the direction of the thumb (perpendicular to the other four fingers) shows the direction of Ampere's force. In general, the direction of Ampere's force is defined by the ordinary vector product of $d\vec{l}$ and \vec{B} .

Since Ampere's force is perpendicular to the magnetic induction strength lines, it is not a central force in comparison to electrostatic force, which is the central one.

As it follows from Ampere's law, a force $d\vec{F}_A$ is maximal, if a conductor element dl carrying a current is situated perpendicular to the lines of magnetic induction.

The magnetic field aligns in a specific way a closed conducting loop carrying a steady current. For example, a square current loop placed into a uniform magnetic field rotates until its plane is perpendicular to the vector of magnetic induction \vec{B} . The reason of this rotation is connected with an appearance of the torque applied to the opposite pair of a square loop wires. The resulting pair of Ampere's forces, which are directed oppositely, rotates a loop.

Ampere's forces which act on a closed current loop placed into a magnetic field can be the reason of the conductor mechanical deformation or break, if a magnetic field is very strong and a current is very large.

If a current loop is placed into a non-uniform magnetic field, there appear both a torque and a resulting force exerted on a closed current loop. As a result, a closed current loop placed into a non-uniform magnetic field does not only rotate but even moves along a gradient of magnetic field. In that sense one says that a behavior of a closed current loop in a non-uniform magnetic field is similar to that of electric dipole in a non-uniform electrostatic field.

4.2 The Flux and Circulation of Magnetic Field

Since the conductor carrying a current when placed into a magnetic field is influenced by Ampere's force, during its displacement to a distance $d\vec{r}$ the work $dA = (\vec{F}_A d\vec{r})$ is done. Let the conductor of the length l and carrying a current I is placed into a uniform magnetic field characterized by magnetic the induction vector \vec{B} directed perpendicularly to the Fig.5.7 plane ("from us"). The conductor is influenced by Ampere's force $F_A = I l B$ and, therefore, is shifted parallel to itself by the distance $d\vec{r}$. Then

$$dA = I B l d r = I B d S, \quad (5.13)$$

where $dS = l d r$ is the surface covered by the conductor upon its motion. As it is seen from Fig.5.7, in this situation the \vec{B} vectors flow through the dS . It is convenient to introduce the new quantity, the flux of magnetic induction vector (magnetic flux) through dS .

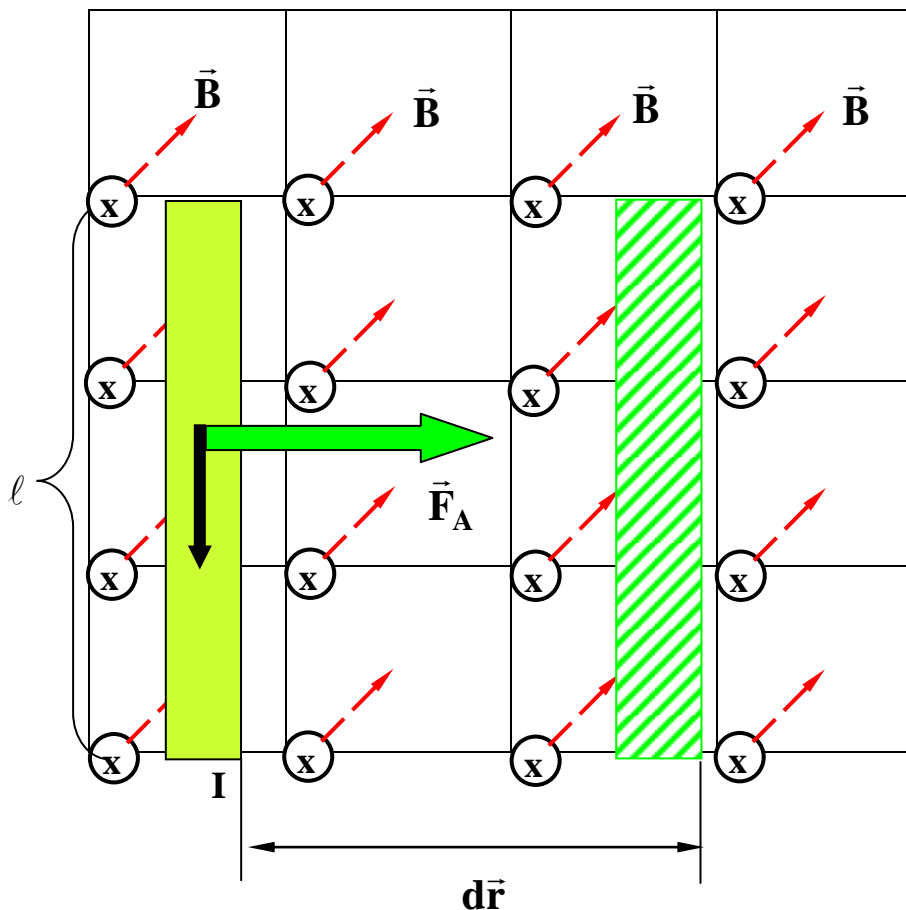

\odot means that \vec{B} is directed \perp to a figure plane

Figure 5.7

The elementary magnetic flux of the vector \vec{B} through elemental surface dS is the scalar quantity defined as

$$d\Phi = (\vec{B}d\vec{S}) = (\vec{B}dS\vec{n}) = B \cdot dS \cdot \cos(\vec{B}\vec{n}), \quad (5.14)$$

where \vec{n} is a unit vector of the outer normal to a surface dS . The total magnetic flux through a surface is determined then as

$$\Phi = \int_S B \cos(\vec{B}\vec{n}) dS. \quad (5.15)$$

It is obvious that in a case of a uniform magnetic field $\Phi = (\vec{B}\vec{S}) = BS \cos(\vec{B}\vec{S})$. The unity of magnetic flux is $[\Phi] = Wb$, $1Wb = 1Tesla / m^2$. The magnetic charges do not exist in nature, therefore the strength lines of magnetic induction are closed and the magnetic flux through an arbitrary closed surface equals zero:

$$\oint_S \vec{B}d\vec{S} = 0. \quad (5.16)$$

The Equation (5.16) is in fact **Gauss' theorem for magnetic induction** in the integral form. The differential form of this theorem reads:

$$div\vec{B} = 0. \quad (5.17)$$

Using the definition of a magnetic flux, we can rewrite Equation (5.13) for a work necessary for displacement in a magnetic field of a conductor carrying a current:

$$dA = Id\Phi. \quad (5.18)$$

Therefore, the work necessary for displacement of a closed current loop in a magnetic field is

$$dA = I(d\Phi_2 - d\Phi_1). \quad (5.19)$$

Here, $(d\Phi_2 - d\Phi_1)$ is a change of a magnetic flux through a surface limited by a closed current loop.

The magnetic field characterized by the closed strength lines is the vortex field. The circulation of a vector \vec{B} along a closed contour is defined as the integral like

$$\oint_l (\vec{B}d\vec{l}) = \oint_l Bdl \cos \alpha.$$

Here, dl - is an element of a contour length taken in the direction of motion along a contour; α - is an angle between the vectors \vec{B} and $d\vec{l}$. In order to calculate the magnetic field caused by a direct (steady) current in a vacuum, one has to use **the law of a total current**, which reads: the circulation of a vector of magnetic induction along an

arbitrary closed contour is proportional to an algebraic sum of the currents closed by this contour:

$$\oint_l (\vec{B} d\vec{l}) = \mu_0 \sum_{i=1}^N I_i . \quad (5.20)$$

Here, N is the total number of conductors (currents) inside a contour l . In this sum a current is taken as positive one if seeing from the end of a vector, the motion along a contour is counter-wise, in opposite case a current is taken as negative one. The currents, which are not inside a closed contour l , do not contribute to the circulation of \vec{B} and every current in Equation (5.20) is taken the same times as it appears inside a contour. For example, in the case of a system of currents shown in Figure 5.8 one obtains:

$$\sum_{i=1}^5 I_i = I_1 + I_2 + 2I_3 - I_4 + 0 \cdot I_5 .$$

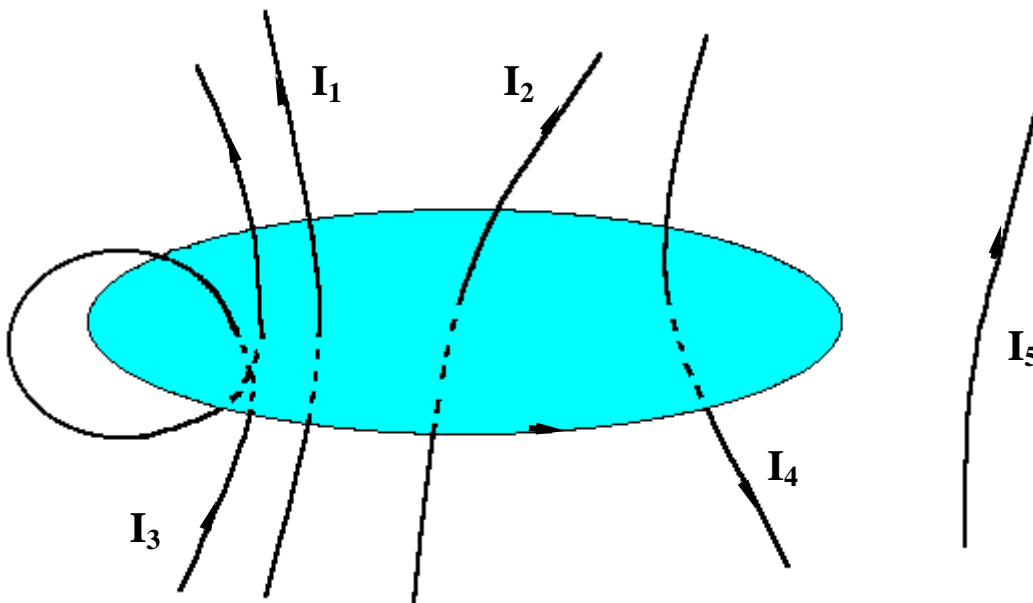

Figure 5.8

Applying the law of total current to the coil (circle-like coil placed on the circle-like core, see Figure 5.9[a]) and to the long solenoid (cylindrical coil consisting of a large number of twists forming a screw-like line, see, Figure 5.9[b]) we get:

$$B_t = \frac{\mu_0 NI}{2\pi r}, \quad B_{sol} = \frac{\mu_0 NI}{l} . \quad (5.21)$$

Here, N is the number of twists in a toroid or solenoid, r is the radius-vector of a point inside a toroid, and l is the length of a solenoid. The generalization of the total current

law for the case when there exist the displacement current and molecular currents inside a material will be given below.

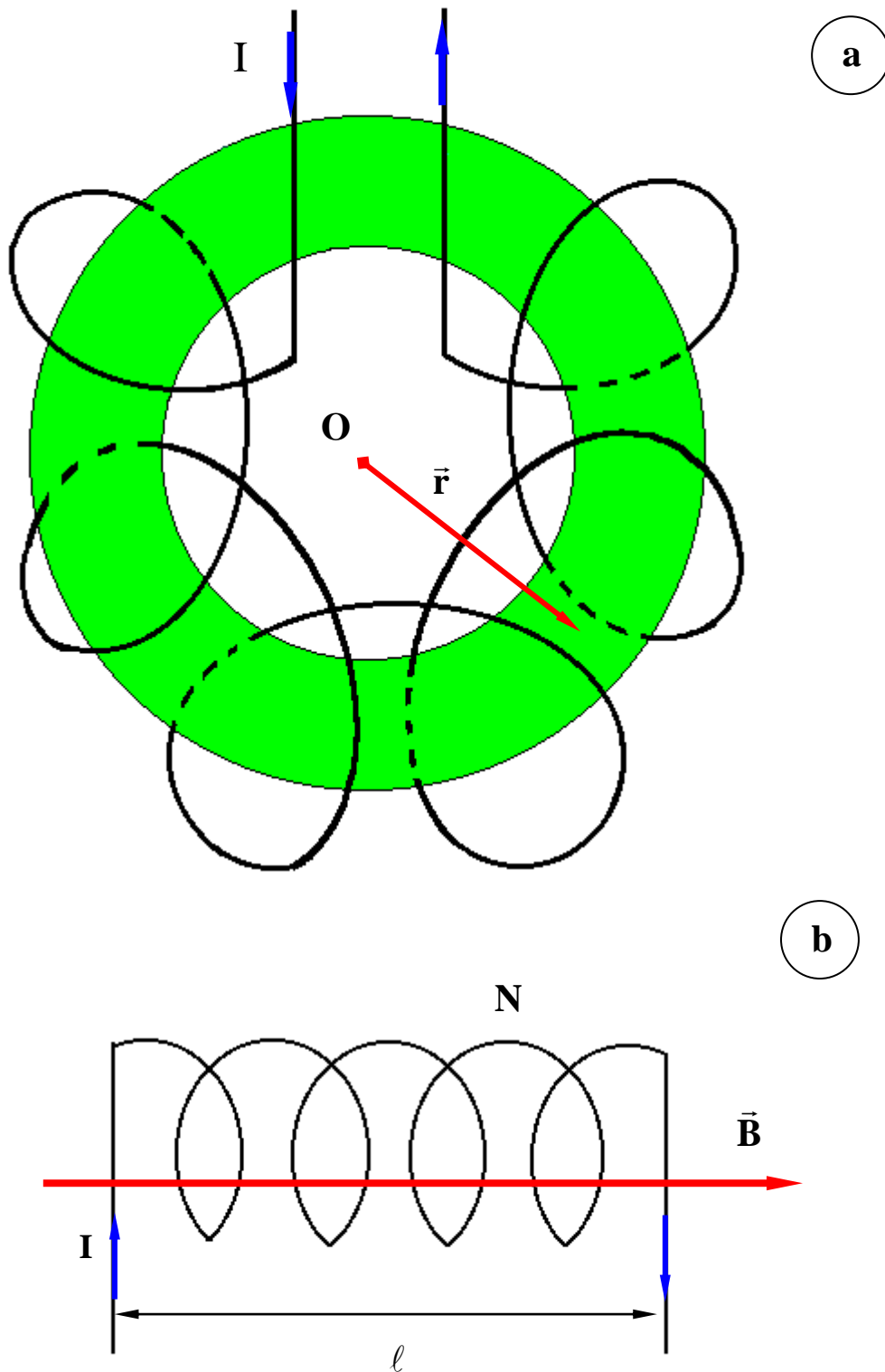

Figure 5.9

4.3 Lorentz's force. Hall's effect

Any electric charge q moving at a velocity \vec{V} in a magnetic field \vec{B} experiences the force which is called the Lorentz force:

$$\vec{F}_L = q[\vec{V}\vec{B}]$$

$$|\vec{F}_L| = F_L = qVB \cdot \sin(\alpha)$$
(5.22)

Here, α - is the angle between the charge velocity \vec{V} and the magnetic induction vector \vec{B} .

Figure 5.10(a) shows mutual arrangement of the vectors $\vec{F}_L, \vec{B}, \vec{V}$ for the case $q > 0$, while Figure 5.10(b) shows it for the case $q < 0$.

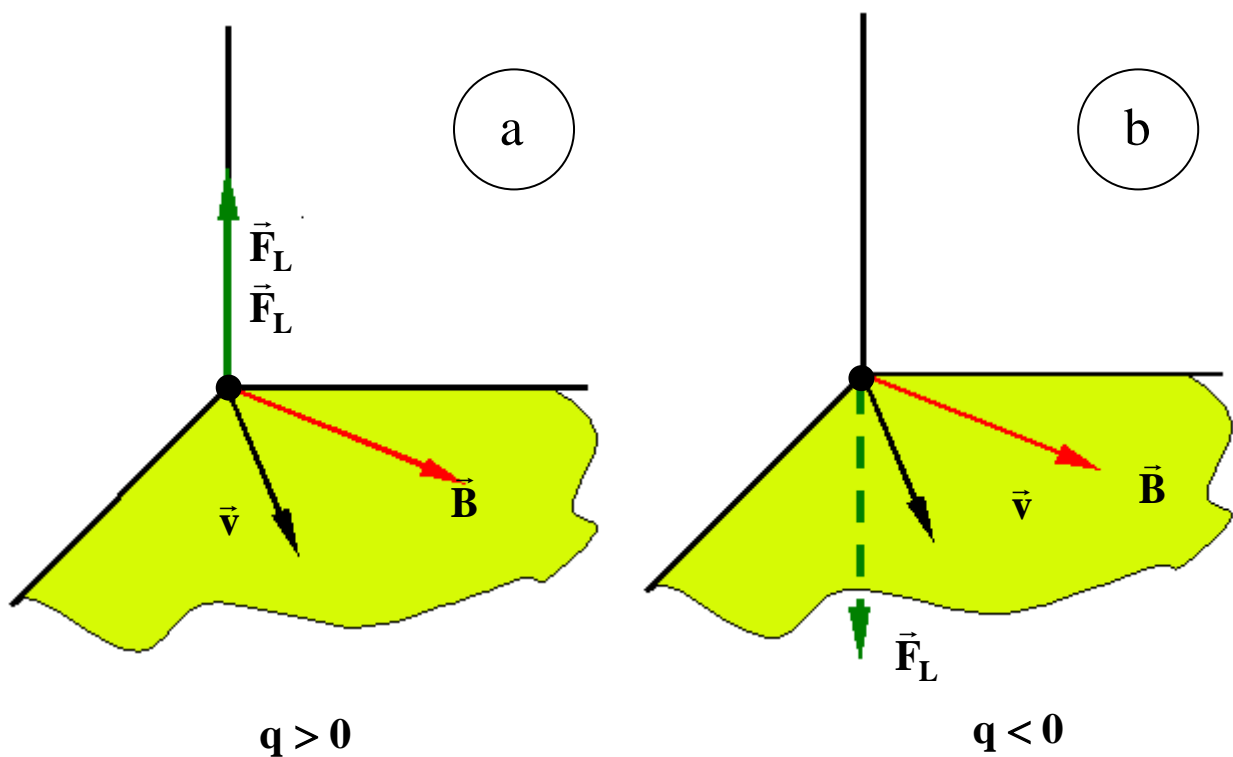

Figure 5.10

Since Lorentz's force \vec{F}_L is perpendicular to the velocity vector \vec{V} , it changes only the direction of \vec{V} but not its value, and, therefore, does not do any work. Therefore, the kinetic energy of a charged particle during its motion in a magnetic field does not change.

In a uniform (\vec{B} does not depend on a coordinate) magnetic field when the vectors \vec{B} and \vec{V} are perpendicular, i.e. $\vec{B} \perp \vec{V}$, Lorentz's force acts as a centripetal force:

$$F_L = F_{Center}, \text{ or } qvB = mv^2/r.$$

Upon action of this force, a charged particle of a mass m moves in a circle of a constant radius $r_B = mvB/|q|$ in a plane being perpendicular to the vector \vec{B} (see Figure 5.11). Therefore, a rotation period T of a charged particle in a uniform magnetic field, $T = 2\pi m/|q|B$, does not depend on the particle velocity. This conclusion serves as a basis to design cyclic accelerators of charged particles.

If the charged particle moves in a uniform magnetic field, so that the velocity vector \vec{V} makes an angle $\alpha \neq \pi/2$ with magnetic field vector \vec{B} (see Figure 5.11), then the particle trajectory is a spiral line characterized by a curvature radius R and a spiral step h :

$$R = \frac{mv \sin[\alpha]}{|q|B}; h = \frac{2\pi mv \cos(\alpha)}{B|q|}.$$

If the magnetic field is non-uniform (see, Fig.5.11), the charged particle moves along a spiral with a changing curvature radius and changing spiral step. E.g., following an increase of the magnetic induction \vec{B} , the radius R and step h of the spiral line decrease.

In modern devices many of considered above features of a motion in a magnetic field are used. For example, for a measurement of a specific particle charge q/m , the deviation of the charged particle caused by Lorentz's force in a magnetic field is used, and the formula $r = mv/|q|B$ is applied. For the determination of the q/m value in the case of heavy ions, the joint action of both magnetic and electric fields is used. In this case the generalized Lorentz's force determines the ion motion:

$$\vec{F}_L = q\vec{E} + q[\vec{V}\vec{B}].$$

This force depends both on an ion charge q and ion velocity \vec{V} and allows the ions separation according to their mass and charge. The device for the measurements of relative atomic masses of the ions and isotopes of chemical elements is called the mass - spectrograph or mass-spectrometer. The devices to obtain the charged particles of high kinetic energy are called accelerators.

In the linear accelerator a particle moves through an electric field having a great voltage created by electrostatic generator, and leaves this field receiving the energy $W = q(\phi - \phi_2)$, which can be up to 10 MeV. In the linear resonance accelerators, the particles are accelerated by an alternating electric field of a very high frequency, which is changing synchronously with a particle motion. These linear accelerators allow the energy of the particles up to tens or hundreds of GeV (1GeV=10⁹ eV).

In the betatrons, specially suited for acceleration of electrons, the vortex electric field is used, which is produced by alternating magnetic field of an electromagnet. The electron trajectories in a betatron are the circles coinciding with the strength lines of a vortex electric field.

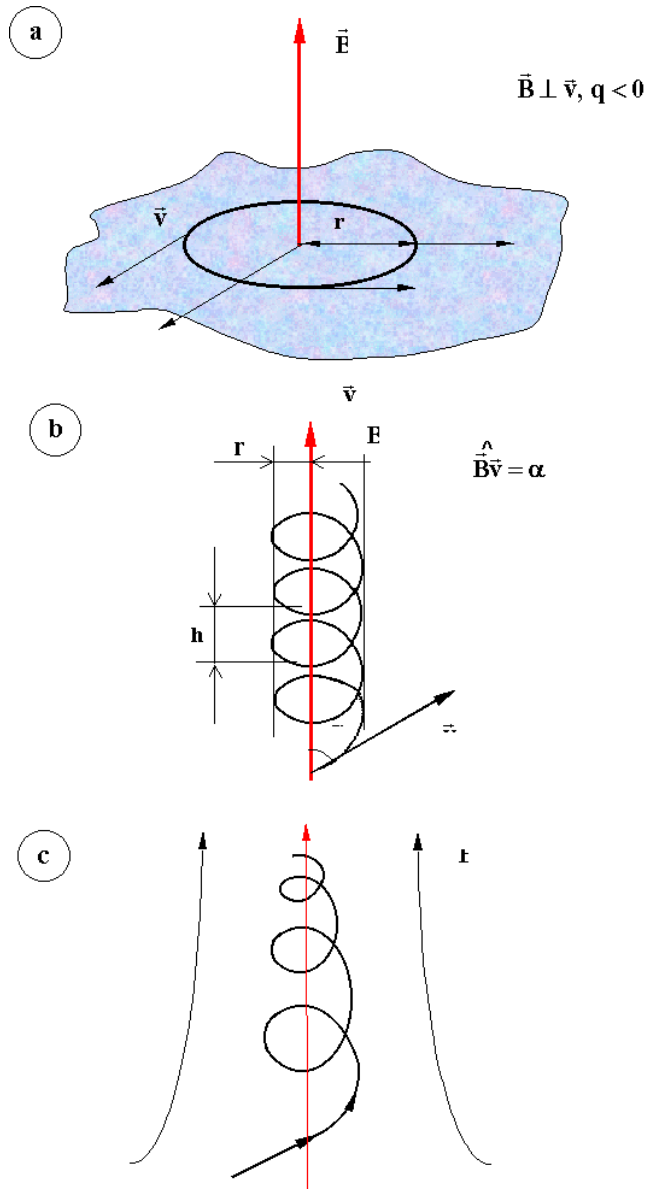

Figure 5.11

To accelerate the heavy charged particles (ions, protons), the cyclic resonant accelerators – cyclotrons - are used. The joint action of alternating accelerating electric field and magnetic field, which enforces the particle motion along the spiral of increasing radius leads to a possibility of acceleration up to high energy (tens of MeV).

To obtain the beams of very high-energy electrons (so called ultrarelativistic electrons with an energy up to 10 GeV), the other type of cyclic accelerator – a synchrotron is used. In a synchrotron, the electrons move in circle of a large (up to 10 m) radius. Unfortunately, the electron synchrotron has serious disadvantage. It is known from electrodynamics, that any charged and accelerated particle radiates electromagnetic waves. In a case of the ions one can neglect this radiation due to a large mass of the ion. In a case of electrons moving in a uniform magnetic field in a circle this radiation is called the synchrotron radiation. Due to radiation, the relativistic electron loses per every revolution an amount of energy

$$W_{rad} = const \cdot \frac{E^4}{R}.$$

Here, E, R are the energy of relativistic electron and an orbit radius, respectively. Therefore, this radiation energy loss must be compensated by additional acceleration in order to keep the electron energy constant. The advantage is that the synchrotron radiation is widely used through the world as the bright source of soft X-rays, which are used in lithography and in biological and medical research.

In electronic optics one studies the properties of charged particle beams (electrons, protons) interacting with electric and magnetic fields. In particular, the diffraction phenomena are studied, which are connected with the wave properties of the particles.

Hall's effect is called a phenomenon when the voltage $\Delta\varphi$ and transverse electric field arises in a metal or semiconductor carrying an electric current I , if they are placed into a magnetic field, which is perpendicular to the current direction. Let the metal conductor be placed into magnetic field characterized by the magnetic induction \vec{B} , as shown in Figure 5.12.

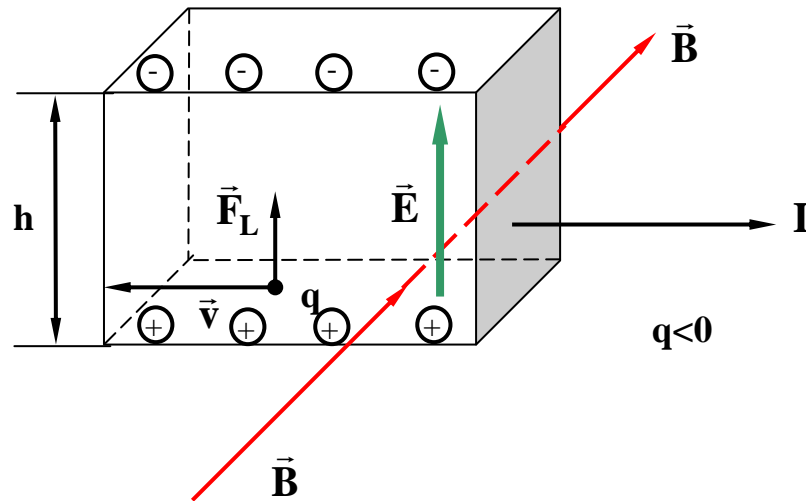

Figure 5.12

Under the action of Lorentz's force F_L , the conductivity electrons are deflected to the upper surface of the conductor. Therefore, the enhanced concentration of positive charges arises near the lower surface. These two oppositely charged surfaces causes the transverse electric field \vec{E}_\perp . When it reaches a definite value, the stationary distribution of charges is established and the voltage can be found using the equation

$$\Delta\varphi = R \frac{IB}{h}, \quad (5.24)$$

with $R = 1/qn$ being Hall's constant (q, n are the charge of particle causing the current and their concentration, respectively). The vector \vec{E}_\perp is defined by the equation

$$\vec{E}_{\perp} = R[\vec{B}j],$$

Here, \vec{j} - is the vector of the current density. Hall's effect allows to determine the concentration of the current carriers and to make conclusions on the type of conductivity (e.g., in the case of semiconductors to conclude on hole, electronic or mixed - n and p type - conductance).

Indeed, the sign of Hall's constant coincides with a sign of the charge of the particles, which are responsible for a conductance of a material. Therefore, if one measures Hall's constant R for a semiconductor, one can say that a conductance is electronic one if $R < 0$ and is hole-type if $R > 0$.

From the other side, if Hall's constant and charge of current carriers and their nature are known one can determine their concentration. E.g., for metals

$$n = 1/(qR),$$

which coincides with atomic concentration.

In a case of electronic conductance, one can use the R value to estimate the mean free path of electrons $\langle \lambda \rangle$ in a conductor. Indeed, the specific electric conductance is defined as

$$\gamma = \frac{ne^2 \langle \lambda \rangle}{2m \langle u \rangle}.$$

Here, m , $\langle \lambda \rangle$ and $\langle u \rangle$ are the mass of electron, its mean free path and mean velocity of thermal motion, respectively. Therefore, the mean free path of electrons is defined by following equation:

$$\lambda = \frac{2m \langle u \rangle \gamma}{ne^2} = \frac{2m \langle u \rangle \gamma |R|}{e}.$$

An estimation according this formula reads that the mean free path of electrons in a conductor is hundreds of interatomic distances, i.e. $\langle \lambda \rangle \cong 10^{-8} m$.

4.4 Electromagnetic induction

The phenomenon of electromagnetic induction discovered by the great English physicist M. Faraday (1831) is the appearance of electric induction ε_i in a conducting contour placed into an alternating magnetic field. If the contour is closed, there appears an inductive electric current inside it. **The law of electromagnetic induction** (Faraday's law) reads: the electric induction in a contour is equal and has an opposite sign to the rapidity of a change of magnetic flux through the surface closed by this contour:

$$\varepsilon_i = -\frac{d\Phi}{dt}. \quad (5.25)$$

The direction of the path along a contour is selected in the following way: if seeing from the end of a normal external vector \vec{n} to the contour surface, this path is counter-clockwise. If a closed contour consists of N connected coils, then Φ is the total magnetic flux through the surfaces limited by all N coils, namely

$$\sum_{i=1}^N \Phi_i = \Psi,$$

Here, Ψ is the contour coupling flux. Therefore,

$$\varepsilon_i = -\frac{d\Psi}{dt}.$$

The minus sign in Equation (5.25) is determined by Lenz's rule: an induction current I in a contour has always the same direction as the magnetic field created by it, and the magnetic flux through the surface limited by a contour prevents the change of magnetic flux, which causes this induction current.

The magnetic flux Φ in Equation (5.25) can be different due to a change of the contour size (e.g., its deformation), or due to the movement of the contour (e.g., rotation) in an external magnetic field, or due to a change of the magnetic field in time. For example, under rotation of a frame in uniform magnetic field $B = \text{const}$ at a constant angular velocity ω , the magnetic flux is $\Phi = BS \cos(\omega t)$, and therefore there appears an alternating electric induction $\varepsilon_i = BS\omega \sin(\omega t)$. This effect is used in the alternating current generators.

The induction currents, which appear in the bulk of the conductors are named the vortex currents or Foucault's currents. Foucault's currents obey Lenz's law: their magnetic field is directed in the way in order to prevent a change of the magnetic flux which induces the vortex currents. These currents cause the heating of the conductors: the amount of the heat generated by vortex currents per time unit is directly proportional to the frequency squared of the magnetic flux change.

The appearance of an electric induction in a circuit during a change of a current in this circuit is named the self-induction. The self magnetic field of a current in a contour creates the magnetic flux Φ through the surface S closed by the contour. One says that the magnetic flux Φ is coupled with a contour,

$$\Phi = LI \quad . \quad (5.26)$$

Here, L - is the inductivity of a contour. The inductivity L is measured in Henrey: $1Hn=Vsec/A$. The inductivity L depends on the geometric form of a contour, its size, and on the properties of a media where this contour is placed. For example, the inductivity of a solenoid of a length l and a surface of cross-section S and the number of twists N is:

$$L = \frac{\mu_0 N^2 S}{l} \quad . \quad (5.27)$$

By substituting of Equation (5.26) into Equation (5.25) one obtains:

$$\varepsilon_i = -L \frac{dI}{dt} \quad . \quad (5.28)$$

That means, the contour inductivity is a measure of its inertia with respect to the current change.

If there are two contours 1 and 2 near each other, and the current strength changes in one of them, in the second one appears an electromagnetic induction. **The law of mutual induction** is written in the form:

$$\varepsilon_2 = -L_{21} \frac{dI_1}{dt}; \varepsilon_1 = -L_{12} \frac{dI_2}{dt} \quad . \quad (5.29)$$

The coefficients $L_{12} = L_{21} = const$ are named the coefficients of mutual inductivity of contours 1 and 2. In particular, the principle of the work of transformers, which are used to increase or decrease the voltage of alternating current, is based on the phenomenon of mutual induction: the alternating magnetic field of the current I in the primary winding causes an appearance of mutual electric induction in the secondary winding. The core provides a sufficient mutual inductivity L_{12} of the transformer.

The magnetic field of an electric current has an energy which can be expressed as:

$$W_m = \frac{1}{2} LI^2 \quad . \quad (5.30)$$

For example, the energy of magnetic field of a long solenoid in a vacuum is:

$$W_m = \frac{1}{2} \mu_0 n^2 I^2 V, \quad (5.31)$$

Here, V - is the volume of a solenoid, n - is the number of the twists per its length unit. In order to obtain the amount of energy closed in a unit volume of a field, one introduces the definition of the volume density of the energy ω_m :

$$\omega_m = \frac{dW}{dV} = \frac{1}{2} \cdot \frac{B^2}{\mu_0} = \frac{1}{2} \mu_0 H^2 = \frac{1}{2} BH , \quad (5.32)$$

Here, $H = B/\mu_0$ is named the strength of a magnetic field in a vacuum.

Problems to Chapter 4 (Magnetic field)

Problem 1

Calculate the magnitude of the magnetic field at a distance 100 cm from a long, thin conductor carrying a current of 1.0 A.

Problem 2

A long, thin conductor carries a current of 10.0 A. At what distance from the conductor the magnitude of the resulting magnetic field equals $1.00 \cdot 10^{-4}$ T ?

Problem 3

A wire in which there is a current of 5.0 A is to be formed into a circular loop of one turn. If the required value of the magnetic field at the center of the loop is 10.0 T, what is the required radius of the loop?

Problem 4

In Bohr's model of the hydrogen atom (1913), an electron circles the proton at a distance of $5.3 \cdot 10^{-11}$ m with a speed of $2.2 \cdot 10^6$ m/s. Compute the magnetic field strength which produces this motion at the location of the proton.

Problem 5

A 12-cm \times 16-cm rectangular loop of superconducting wire carries a current of 30 A. What is the magnetic field at the center of the loop?

Problem 6

A long, straight wire lies on a horizontal table and carries a current of 1.2 A. A proton moves parallel to the wire (opposite the current) with a constant speed of $2.3 \cdot 10^4$ m/s at a distance d above the wire. Determine the value of d . You may ignore the magnetic field due to the Earth.

Problem 7

The magnetic coil of a tokamak fusion reactor is in the shape of a toroid having an inner radius of 0.70 m and outer radius of 1.30 m. If the toroid has 900 turns of large-diameter wire, each of which carries a current of 14 kA, find the magnetic field strength along (a) the inner radius and (b) the outer radius.

Problem 8

A packed bundle of 100 long straight, insulated wires forms a cylinder of radius $R = 0.5$ cm. (a) If each wire carries a current of 2.0 A, what are the magnitude and direction of the magnetic force per unit length acting on a wire located 0.2 cm from the center of the bundle? (b) Would a wire on the outer edge of the bundle experience a force greater or smaller than the value calculated in part (a)?

5. MAGNETIC FIELD IN MATTER

5.1. Magnetic moments of atoms

The magnets are those materials, which can be magnetized in a magnetic field, i.e. can create their own magnetic field. The molecule (atom, ion) is a dynamic system consisting of charged particles and has its own magnetic field. The molecules can create inside a substance the resulting magnetic field \vec{B}_{int} , which is called the internal magnetic field. This magnetic field arises due to existence of magnetic moments \vec{p}_m of molecules, atoms or ions. E.g., the electron motion along a closed orbit around a nucleus can be considered as the circle current loop $I = e\nu$ (where e^- is the electron charge, ν - is the rotation frequency around nucleus). Therefore, one can associate with the current I the magnetic moment

$$(\vec{P}_m)_{orb} = e\nu S\vec{n}.$$

Here S - is the orbit surface and \vec{n} is a unit vector normal to S . This magnetic moment is called the **orbital magnetic moment of electron**. The mutual arrangement of the vectors of electron orbital angular momentum \vec{L} , orbital magnetic moment \vec{P}_m and electron velocity \vec{v} is shown in Figure 6.1

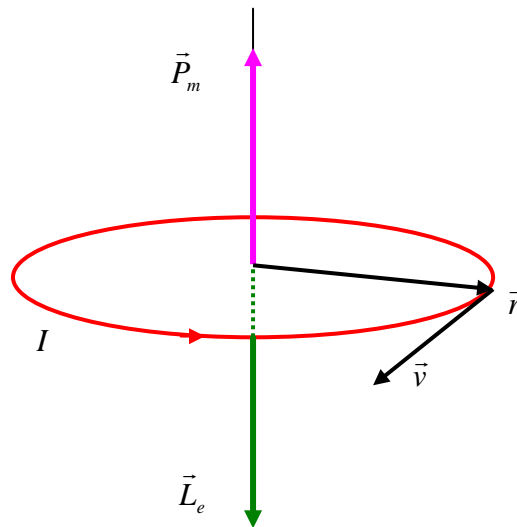

Figure 6.1

It follows from relativistic quantum mechanics that the electron has intrinsic angular momentum \vec{S} , which is named the spin. As a sequence, an electron has also its **spin magnetic moment**

$$\vec{P}_{mS} = g_s \cdot \vec{S}, S_z = \pm \frac{1}{2} \cdot \hbar, g_s = -\frac{e}{m}.$$

Here S_z - is the projection of electron own angular momentum (or spin) onto a chosen axis and g_s - is the gyro-magnetic ratio for a spin angular momentum, \hbar - is Planck's constant and e, m are the mass and charge of electron.

Thus, the magnetic moment of an electron in an atom \vec{P}_{me} is a sum of orbital and spin magnetic moments: $\vec{P}_{me} = (\vec{P}_m)_{orb} + \vec{P}_{ms}$. As a sequence, the magnetic moment of an atom is the sum of magnetic moments of all electrons of an atom and the magnetic moment of atomic nucleus $(\vec{P}_m)_{nucl}$ which is sufficiently less (up to thousands times) as compared to magnetic moment of an electron \vec{P}_{me} .

Therefore, the magnetic moment of an atom $(\vec{P}_m)_{at}$ (or of a molecule) equals to a vector sum of orbital and spin magnetic moments of all electrons from which an atom (a molecule) consists:

$$(\vec{P}_m)_{at} = \sum_{i=1}^Z (\vec{P}_m)_i + \sum_{i=1}^Z (\vec{P}_{ms})_i, \quad (6.1)$$

Here, Z - is the number of electrons of an atom (molecule).

If one places a magnet in a magnetic field \vec{B} , this magnetic field acts on the magnetic moments of the atoms of the magnet. Let the electron orbit be oriented with respect to the vector \vec{B} in the way that the vector of the magnetic moment of the electron \vec{P}_m makes a certain angle α with \vec{B} (see Figure 6.2).

Due to the interaction of the electron magnetic moment \vec{P}_m with the magnetic field \vec{B} , there arises a rotation of the electron orbit and connected with this orbit vector \vec{P}_m around the \vec{B} vector, with an angular velocity ω_L . This kind of rotation is called precession and is characterized by Larmor's theorem. Larmor's theorem reads: the magnetic field influences an electronic orbit in such a way that the orbit makes a precession while the vector \vec{P}_m rotates around the axis transmitting through the center of an orbit parallel to magnetic induction vector \vec{B} (or parallel to a vector of magnetic field strength \vec{H}) with an angular frequency ω_L which is named Larmor's frequency:

$$\omega_L = \frac{eB}{2m} = \mu_0 \frac{eH}{2m}. \quad (6.2)$$

Thus, an electron makes a complicated motion in a magnetic field: it moves along its orbit, and the orbit makes precession around \vec{B} . This complicated motion causes additional (induced by magnetic field) orbital magnetic moment of the electron $\Delta\vec{P}_m$, which is directed opposite to \vec{B} (or to \vec{H}) vector (see Figure 6.1). Then, the total induced orbital magnetic moment of an atom is:

$$(\Delta\vec{P}_m)_{at} = \sum_{i=1}^Z (\Delta\vec{P}_m)_i. \quad (6.3)$$

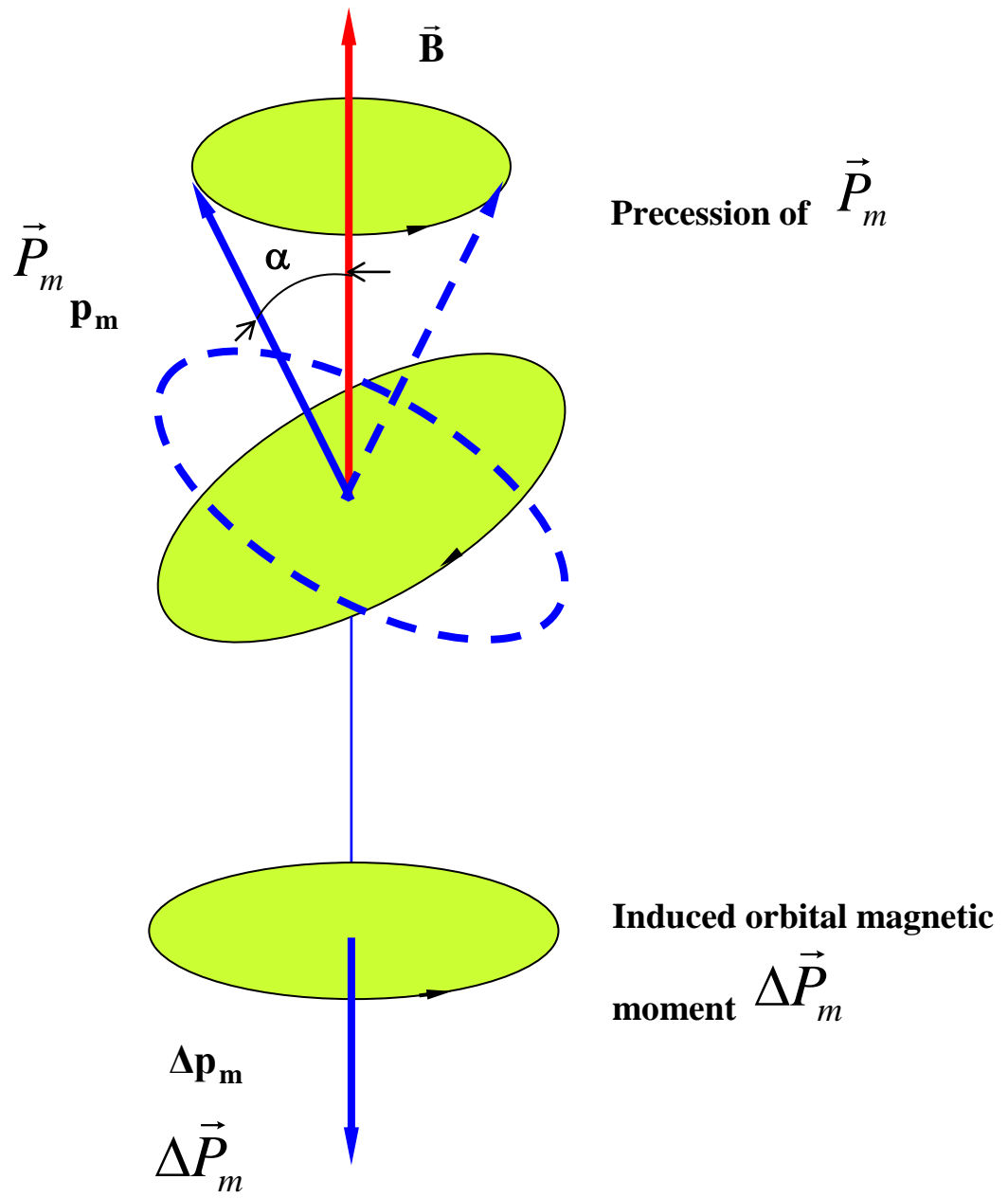

Figure 6.2.

5.2 Magnetic properties of matter

The magnetic field created by the molecules (atoms, ions) of a magnetic material due to the existence of their own magnetic moments is called the internal (own, intrinsic) magnetic field. The resulting magnetic field in a magnetic material is thus the sum of the vector of magnetic induction of external (primary, or magnetizing) field \vec{B} (which is created by macroscopic currents, e.g. conductivity current, convection current) and internal magnetic field \vec{B}_{int} (which is created by molecular currents in the magnetic material):

$$\vec{B}_0 = \vec{B} + \vec{B}_{\text{int}} . \quad (6.4)$$

When a uniform and isotropic magnetic material fully occupies the space, then in the magnetic material $\vec{B} = \mu\vec{B}_0$, where $\vec{B}_0 = \mu_0\vec{H}$ - is the magnetic induction in vacuum. The physical quantity μ of magnetic material is called the relative magnetic permeability of magnetic material, and it shows how many times the magnetic induction at a given point of the given material is greater than that in vacuum, for the given distribution of macroscopic currents.

In order to characterize the degree of magnetizing of a material one introduces the magnetizing vector \vec{J} , which is a vector sum of magnetic moments of molecules (atoms) per unit volume of magnetic material:

$$\vec{J} = \lim_{V \rightarrow 0} \left(\frac{1}{V} \sum_{i=1}^N (\vec{P}_m)_i \right) . \quad (6.5)$$

Here, N - is the number of molecules (atoms) in the volume V of magnetic material and $(\vec{P}_m)_i$ - is the magnetic moment of i^{th} molecule (atom). When the magnetic material is inside a weak magnetic field, then

$$\vec{B}_{\text{int}} = \mu_0\vec{J}, \vec{J} = \kappa\vec{H} . \quad (6.6)$$

Here, κ - is the magnetic permeability of a material. Combining Equation (6.4) and Equation (6.6) one finds the connection between magnetic induction \vec{B} , magnetic field strength \vec{H} and magnetizing vector \vec{J} :

$$\frac{\vec{B}}{\mu_0} = \vec{H} + \vec{J} . \quad (6.7)$$

Rewriting Equation (6.7) in a form

$$\vec{B} = \mu_0\vec{H} + \mu_0\vec{J} = \mu_0\vec{H} + \mu_0\kappa\vec{H} = \mu_0(1 + \kappa)\vec{H} = (1 + \kappa)\vec{B}_0 ,$$

and then using by definition $\mu = B/B_0$, one gets easily the connection between magnetic permeability and receptivity of an isotropic magnetic material, i.e.

$$\mu = 1 + \kappa . \quad (6.8)$$

Taking into account Equations (6.4) and (6.7), the total current law for a case of magnetic field in a material now has the form:

$$\oint_l \vec{B} d\vec{l} = \mu_0 \sum_{i=1}^N I_i + (I_{mol})_i ; \quad (6.9)$$

$$\oint_l \left(\frac{\vec{B}}{\mu_0} - \vec{J} \right) d\vec{l} = \sum_{i=1}^N I_i .$$

Here, I_i - are the macro-currents (conductivity currents) and $(I_{mol})_i$ - are the micro-currents (molecular currents).

5.3 Classification of Magnetic Materials (Substances)

According to the magnetic properties, the magnetic materials are divided into three groups: diamagnets, paramagnets and ferromagnets.

The diamagnets (e.g., zinc Zn, gold Au, bismuth Bi) are the magnets the molecules (atoms, ions) of which do not have the resulting magnetic moment \vec{P}_m . That means, the magnetic moment $\Delta\vec{P}_m$ induced by the external magnetic field in the electronic shell of a molecule is much greater than \vec{P}_m , $\Delta\vec{P}_m \gg \vec{P}_m$. This feature results in a vector

$$\vec{J} = \frac{1}{V} \sum (\Delta\vec{P}_m),$$

which is directed opposite to the vector of the magnetic field strength \vec{H} ($\vec{J} \uparrow \downarrow \vec{H}$), and, therefore, in accordance with Equation (6.6) $\kappa < 0$ (or $\vec{J} = -\kappa\vec{H}$). For majority of diamagnets, the magnitude of κ is very small ($\kappa \approx 10^{-4} \div 10^{-6}$), while $\mu < 1$, but is close to unity. These facts testify that the magnetic field of molecular currents is much less than the magnetizing field.

The paramagnets (e.g. salts of Cobalt Co, Nickel Ni, Platinum Pt) are the magnets the molecules (atoms, ions) of which have a permanent magnetic moment \vec{P}_m , which does not depend on the external magnetic field. If the external field is absent, the thermal motion does not allow the primary orientation of \vec{P}_m vectors with respect to the field direction. When the paramagnet is placed into a magnetic field, the orientation of the \vec{P}_m vectors occurs and this leads to a magnetizing of the material, i.e. the vector \vec{J} appears. Since in this case the induced magnetic moments $\Delta\vec{P}_m$ are less than \vec{P}_m , the resulting vector \vec{J} is directed along the field (i.e., $\vec{J} \uparrow \uparrow \vec{H}$) and therefore $\vec{J} = \kappa\vec{H}$, with $\kappa > 0$ and $\mu > 1$. For paramagnets the value of κ is small ($\kappa \approx 10^{-4} \div 10^{-6}$), as in the case of diamagnets, and μ only slightly differs from unity. For many paramagnets the κ value depends on the temperature, and this dependence is Curie's law:

$$\kappa = \frac{C}{T} . \quad (6.10)$$

Here, C - is Curie's constant. There are paramagnets, too, for which the κ value does not depend on the temperature.

The ferromagnets (e.g., Lithium Li, Sodium Na, Potassium K, Rubidium Rb) are the magnetics for which the magnetizing depends on the strength of a magnetic field. The magnetic permeability of ferromagnet depends on the magnetic field, $\mu = f(\vec{H})$, and its magnitude is large, $\mu \approx 10^3 \div 10^5$ (see Figure 6.3[b]). The dependence of the magnetic induction \vec{B} on the magnetic field strength \vec{H} is called the magnetizing curve (see Figure 6.3c). The dependence $\mu(H)$ is named Stoletov's curve. Since $\mu = B/\mu_0 H$, using the magnetizing curve one can determine the magnetic permeability of a material for every given value of the field strength.

A large value of ferromagnet magnetizing is explained by a strong interaction of the electronic magnetic spin moments with the magnetic field which results in the primary orientation (alignment) of the magnetic spin moments of atoms in the ferromagnet lattice. As a sequence, the whole ferromagnet is divided into the regions characterized by their own spontaneous magnetizing (up to a total saturation). These regions are called the domains (see Figure 6.3 [d]).

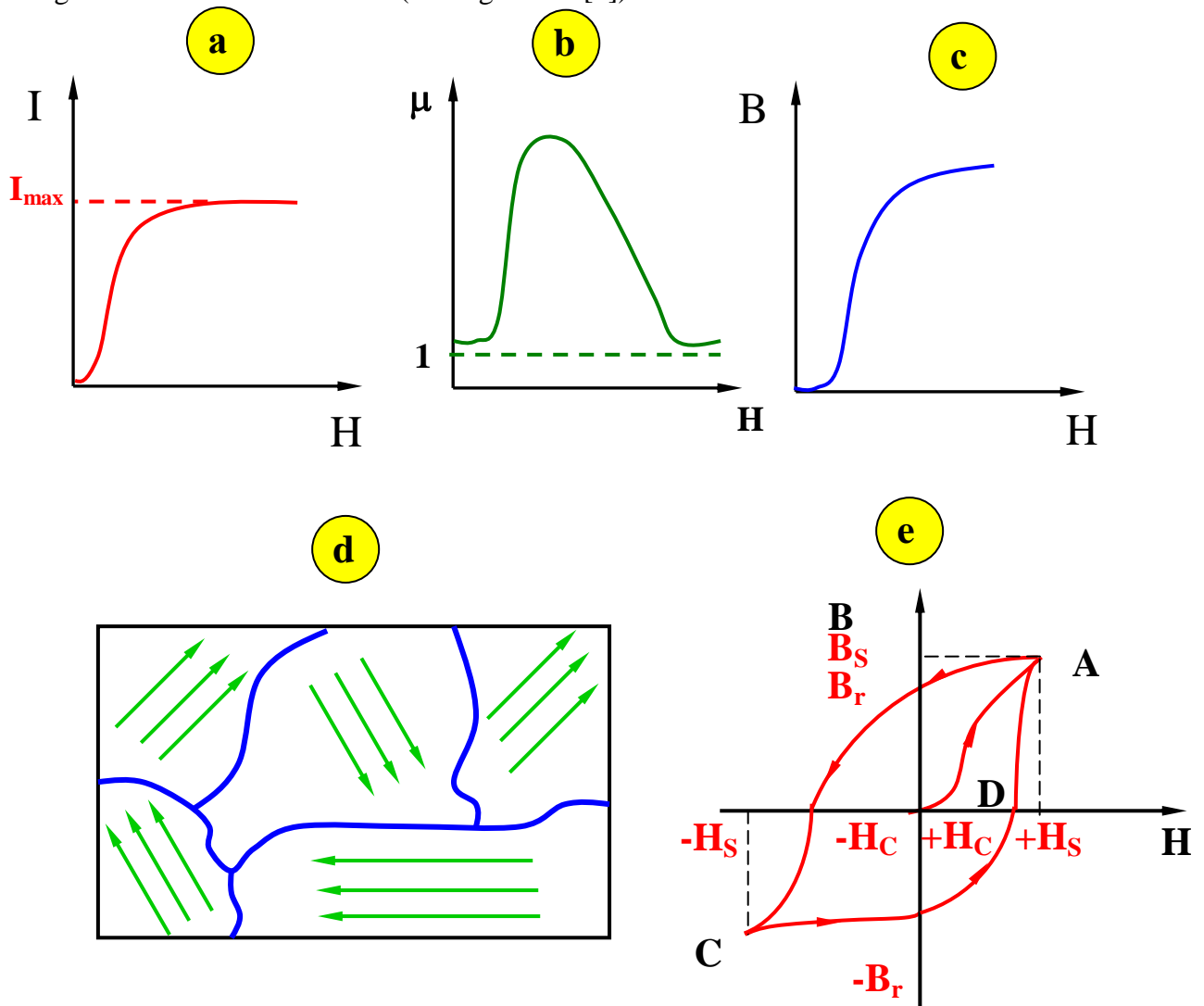

Figure 6.3

In the absence of external magnetic field the directions of the magnetizing vectors of different domains do not coincide and as a sequence, the resulting magnetizing of a whole ferromagnet equals zero. The linear dimensions of the domains are of order of 10^{-2} cm . Their shape and dimensions are determined by the condition of minimal free energy (enthalpy) of a whole ferromagnet. The regions with parallel alignment of the spin magnetic moments of neighbor atoms (within a domain volume) determine the ferromagnet properties (e.g., Fe, Co, Ni), while the regions with anti-parallel alignment of the spin magnetic moments determine the anti-ferromagnet properties (iron Fe and Chromium Cr salts). The specific properties of ferromagnet and anti-ferromagnet are displayed only at temperatures less than Curie temperature (T_C) and Neel's temperature (T_N), respectively. The dependence of the Curie constant κ on the temperature for ferromagnet and anti-ferromagnet is determined by the Curie-Weiss law:

$$\kappa = \frac{C}{T - T_C}; \kappa = \frac{C}{T - T_N}. \quad (6.11)$$

When the ferromagnet is placed into an external magnetic field, the process of its magnetizing is going on due to: a) the change of directions of spontaneous magnetizing of separate domains and of the magnet as a whole following the alignment of the vectors \vec{P}_m parallel to the external magnetic field direction; b) displacements of the domains frontiers which lead to an increase of the domains volumes having the direction of magnetizing most close to a direction of an external magnetic field, due to decrease of the neighboring domains volumes.

These processes result in a magnetizing curve (see Figure 6.3 [e]), which goes first from the point $H = 0$ up to the point A along OA line until saturation (until B_s). After that, decreasing the field up to zero, we arrive at the point B_l which is called the residual induction: that means that the ferromagnet remains magnetized after its removal from an external magnetic field. In order to remove the magnetizing, it is necessary to place it into the magnetic field of the opposite direction. Then $J = 0$ at $H = H_C$ and the value H_C of magnetic field strength at which the magnetic induction $B = 0$ is called the coercitive force. The ferromagnet characterizing by the small coercitive force are called soft-magnets while those characterizing by large coercitive force are called hard-magnets.

A further increase of the magnetic field strength H leads to the re-magnetizing of the ferromagnet (the point C corresponds to a new saturation of a magnet). The curve $AB_l H_C CDA$ (see Figure 6.3[e]) characterizing the change of magnetic induction of a ferromagnet placed into an external magnetic field is called the magnetic hysteresis loop. The magnetic hysteresis is a sequence of non-reverse changes occurring during magnetizing and re-magnetizing of a ferromagnet, namely a sequence of non-reverse processes of displacements of frontiers between domains and processes of magnetizing vectors alignments inside the domains. The surface of the hysteresis loop S is directly proportional to the work done under re-magnetizing, i.e. $S = \oint HdB$. This work determines the energy loss during hysteresis.

Since in a magnetic field inside the ferromagnet there appears a change (reconstruction) of the magnet structure (e.g. the displacement and rotation of the domains frontiers), the ferromagnet dimensions change. The magnetostriction

phenomenon is the change of the shape and dimensions of a ferromagnet under its magnetizing. When a ferromagnet is placed into a periodically changing magnetic field, the mechanical oscillations appear in a ferromagnet, which are called magnetostriction oscillations. In the case of ferromagnets, there exists also the phenomenon, which is reverse with respect to magnetostriction, the change of a ferromagnet magnetizing following its deformation.

6. Maxwell's Equations

6.1 Maxwell's Equations in an Integral Form

As it was shown in Section 4, the phenomenon of electromagnetic induction in a motionless conducting contour is caused by an alternating magnetic field which excites the electromotive force and the induction current. In a closed contour a current of this nature can appear, if in the contour acts the vortex electric field, i.e. the electric field, which has closed force lines. Thus the phenomenon of electromagnetic induction (following Faraday) is connected with the excitation of the vortex electric field by an alternating magnetic field. The circulation of a vortex electric field taken along a closed contour l equals

$$\oint_l (\vec{E} d\vec{l}) = - \frac{d\Phi}{dt}. \quad (7.1)$$

James C. Maxwell in 1881 proposed the generalization of (7.1) and formulated the law of electromagnetic induction: **any alternating magnetic field generates the vortex electric field at any point of space.**

In other words, he suggested that Equation (7.1) is true for any (not only conducting) contour which is arbitrary chosen in an alternating magnetic field. Since $\Phi = \oint_S (\vec{B} d\vec{S})$, Equation (7.1) is rewritten in a form:

$$\oint_l (\vec{E} d\vec{l}) = - \oint_S \left(\frac{d\vec{B}}{dt} d\vec{S} \right). \quad (7.2)$$

Equation (7.2) is the **1st Maxwell's equation** written in an integral form or is Faraday's law of induction.

The law of total current (Ampere's law), written in a form

$$\oint (\vec{H} d\vec{l}) = \sum_{i=1}^N I_i = I_{cond} = \int_S (\vec{j}_{cond} d\vec{S}),$$

leads to the conclusion that the vortex magnetic field is created by the conductivity currents, with \vec{j}_{cond} being the density of conductivity currents. Maxwell suggested in addition that a vortex magnetic field could be generated by an alternating electric field. According to this suggestion, the alternating electric field causes so called displacement current, the density of which is

$$\vec{j}_d = \frac{d\vec{D}}{dt},$$

where \vec{D} - is the vector of electric displacement. For example, the density of displacement current in a dielectric is

$$\vec{j}_d = \varepsilon_0 \frac{d\vec{E}}{dt} + \frac{d\vec{P}}{dt}.$$

Here, the first term is the density of displacement current in vacuum and the second one is the density of polarization current (\vec{P}). Taking into account the displacement current, we rewrite the law of the total current in the form:

$$\oint_l (\vec{H}d\vec{l}) = \int_s \left(\vec{j}_{cond} + \frac{d\vec{D}}{dt} \right) d\vec{S}. \quad (7.3)$$

Equation (7.3) is the **2nd Maxwell's equation written in an integral form**. This law reads that the magnetic field can be excited both by conductivity currents and alternating electric field.

Taking into account Gauss' theorem for an electrostatic field,

$$\oint_s \vec{D}d\vec{S} = \int_v \rho dV,$$

where ρ - is the volume density of electric charges inside a volume V closed by a surface S , and Gauss' theorem for steady magnetic field,

$$\int_s \vec{B}d\vec{S} = 0,$$

finally we can rewrite the integral Maxwell's equations in the form:

$$\begin{aligned} \oint_l \vec{E}d\vec{l} &= -\int_s \left(\frac{d\vec{B}}{dt} d\vec{S} \right); \\ \oint_l \vec{H}d\vec{l} &= \int_s \left(\vec{j}_{cond} + \frac{d\vec{D}}{dt} \right) d\vec{S}; \\ \int_s \vec{D}d\vec{S} &= \int_v \rho dV; \\ \int_s \vec{B}d\vec{S} &= 0. \end{aligned} \quad (7.4)$$

This set of equations describes the fields generated by macroscopic charges and currents, concentrated in a volume V , which is much greater than the volume of a

separate molecule, and at the distances much greater than the linear dimensions of the molecules. In this sense, Maxwell's theory is the macroscopic theory of electromagnetic currents.

6.2. Maxwell's Equations in the Differential Form

Maxwell's equations in an integral form (see Equation 7.4) can be rewritten in another (differential) form. In order to do it, we should apply Stokes's theorem for the circulation of the vector,

$$\oint_l \vec{A} d\vec{l} = \int_s (\text{rot} \vec{A} \cdot d\vec{S}),$$

to the two first equations of (7.4.), and Gauss' theorem for divergence of a vector,

$$\int_s \vec{A} \cdot d\vec{S} = \int_v \text{div} \vec{A} dV,$$

to the last two equations of (7.4.). By means of this operation one can rewrite the set of equations (7.4) in the following form:

$$\begin{aligned} \text{rot} \vec{E} &= -\frac{d\vec{B}}{dt}; & \text{div} \vec{D} &= \rho, \\ \text{rot} \vec{H} &= \vec{j}_{cond} + \frac{d\vec{D}}{dt}; & \text{div} \vec{B} &= 0. \end{aligned} \quad (7.5)$$

The set of Equations (7.5) is the set of Maxwell's equations in the differential form. These equations tell us that in a media, which is at rest the alternating magnetic field creates the vortex electric field, and vice versa the alternating electric field creates the magnetic field. The important property of these equations is their invariance respective to Lorentz's relativistic transformations.

The vectors \vec{E} and \vec{H} of the electromagnetic field can be expressed through the scalar φ and vector $\vec{\Psi}$ potentials:

$$\vec{E} = -\text{grad} \varphi - \frac{\partial \vec{\Psi}}{\partial t}, \quad \vec{H} = \frac{1}{\mu\mu_0} \text{rot} \vec{\Psi}.$$

These potentials satisfy the following equations:

$$\Delta \varphi = \frac{1}{V^2} \frac{\partial^2 \varphi}{\partial t^2}; \quad \Delta \vec{\Psi} = \frac{1}{V^2} \frac{\partial^2 \vec{\Psi}}{\partial t^2}, \quad (7.6)$$

where Δ - is Laplace's operator. These equations are used for the analysis of electromagnetic waves propagation in the medium. Here, V is the velocity of a wave propagation in a medium, which in the vacuum is $V = c$, where c - is the light velocity.

The energy of the electromagnetic field is characterized by the volume energy density W :

$$W = \frac{1}{2}(\epsilon \epsilon_0 E^2 + \mu \mu_0 H^2) \quad (7.7)$$

The amount of energy transferred through the unity surface which is perpendicular to the direction of electromagnetic wave propagation, and per time unity is determined by Poynting's vector \vec{P} :

$$\vec{P} = [\vec{E}\vec{H}]. \quad (7.8)$$

The vectors $\vec{P}, \vec{E}, \vec{H}$ are mutually perpendicular. The magnitude of Poynting's vector determines the density of the energy flux of an electromagnetic wave.

The law of energy conservation of an electromagnetic field connects the divergence of the \vec{P} vector and the time derivative of the volume density W of the energy:

$$\text{div}\vec{P} + \frac{dW}{dt} = 0. \quad (7.9)$$

The properties of an electromagnetic field are different in various inertial frames. For example, let the inertial frame K be at rest, while another inertial frame K' moves uniformly and rectilinearly relative to the frame K , at a constant velocity v . If in the K' frame the magnetic field is absent ($\vec{H}' = 0$) and the electric field is \vec{E}' , in the K frame appear both electric and magnetic fields, and what's more the magnetic field $\vec{H} = [\vec{v}\vec{E}']$. If in the K' frame the electric field is absent ($\vec{E}' = 0$) and the magnetic field is \vec{H}' , in the K frame appears an electric field $\vec{E} = -[\vec{v}\vec{H}']$.

Thus, the relativity of electric and magnetic fields manifests itself in a way that if one of the fields (electric or magnetic one) is absent in one inertial frame, it exists in another inertial frame moving respective to the first one.

7. ELECTROMAGNETIC OSCILLATIONS AND WAVES

7.1 Electromagnetic oscillations

Electromagnetic oscillations appear in an oscillatory circuit which consists of a capacitor C and an inductivity coil L (see Figure 8.1[a]).

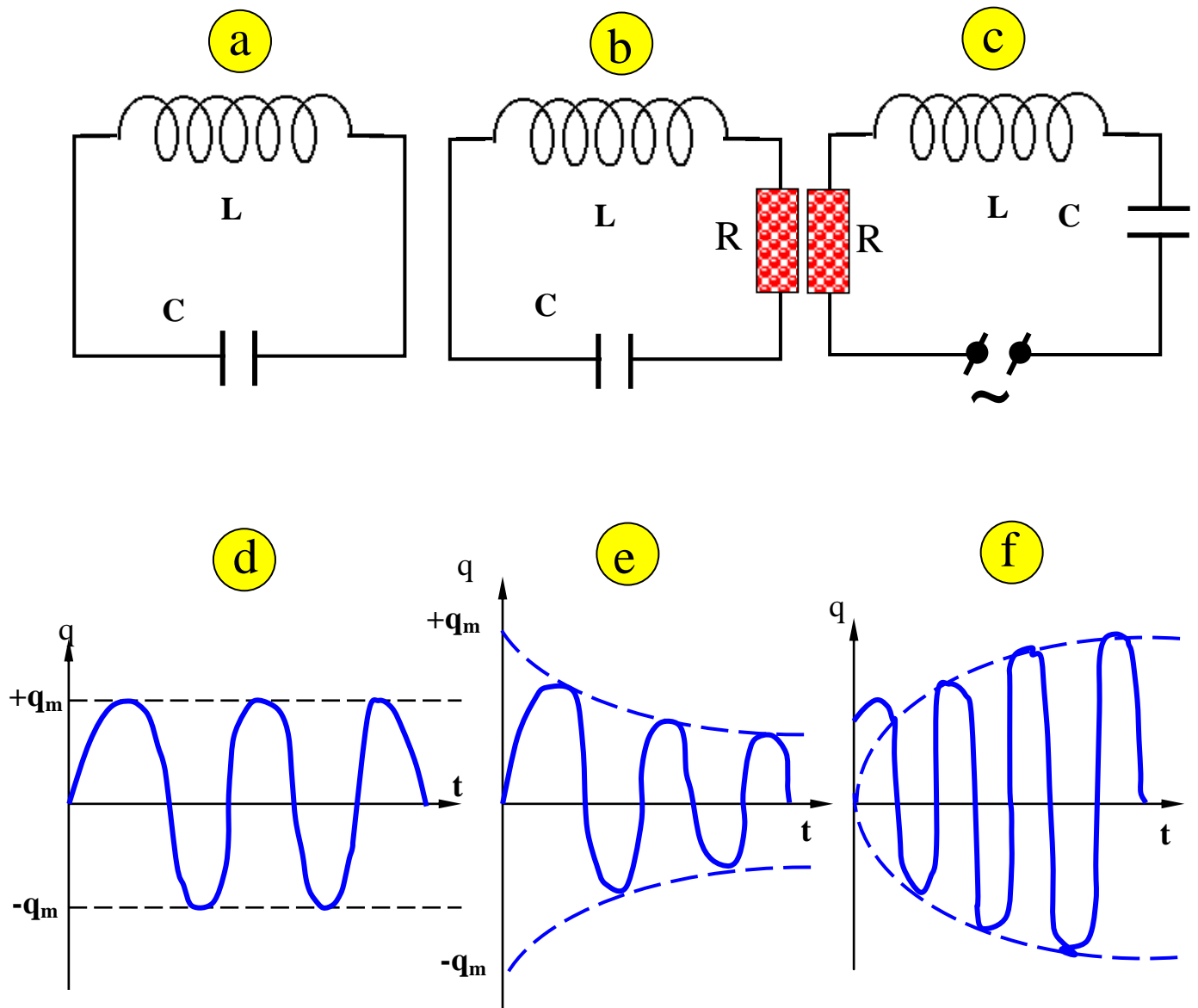

Figure 8.1

If one brings a charge q to a capacitor C , the capacitor begins to discharge through the inductivity coil. The discharge current creates a magnetic field in the coil. At the time moment $t = T/4$ (T – is the period of electromagnetic oscillations), the

energy of the electromagnetic field equals zero while the energy of the magnetic field reaches its maximum value. At a greater time the magnetic field in the coil decreases and the electric current in the coil is induced. This current again charges the capacitor, but now its polarity is opposite. At a time moment $t = T/2$ the energy of magnetic field equals zero, while the energy of electric field reaches its maximal value. At greater times these processes go on in reverse direction, and at the time moment $t = T$ the oscillatory circuit returns to its initial state.

Thus, in a circuit exist the oscillations of electric charge at the capacitors plates (with a period T), the oscillations of the current in a circuit (with a period T) and the oscillations of the energy of electric and magnetic fields. At the time moments $t = 0, T/2, T$ the energy of the electric field is maximal while the energy of magnetic field equals zero. At the time moments $t = T/4, 3T/4$ the energy of the magnetic field is maximal while the energy of the electric field equals zero.

The differential equation describing the free non-damping oscillations in an oscillatory circuit consisting of an inductivity coil L and a capacitor C (assuming a resistance $R=0$) has the form:

$$\frac{d^2 q}{dt^2} + \omega_0^2 q = 0, \quad (8.1)$$

where $\omega_0 = 1/\sqrt{LC}$ - is the self-frequency of undamped oscillations. As a sequence, the period of oscillations is determined by Thompson's formula: $T_0 = 2\pi/\omega_0 = 2\pi\sqrt{LC}$. The solution of Equation (8.1) is

$$q(t) = q_m \sin(\omega_0 t + \varphi_0), \quad (8.2)$$

where q_m - is the maximal value of a charge on the capacitor's plate and φ_0 - is the initial phase. Using this solution, the current in the oscillatory circuit is defined by the equation

$$I(t) = \frac{dq(t)}{dt} = I_m \sin(\omega_0 t + \varphi_0 - \pi/2),$$

with $I_m = \omega_0 q_m$ being the current amplitude (current maximal value). Using these solutions for $q(t)$ and $I(t)$, the energy of electric and magnetic fields in the oscillatory circuit can be written in the following form:

$$\begin{aligned} W_{el}(t) &= \frac{q^2}{2C} = \frac{q_m^2}{2C} \sin^2(\omega_0 t + \varphi_0) = \frac{q_m^2}{4C} [1 - \cos 2(\omega_0 t + \varphi_0)]; \\ W_m(t) &= \frac{I^2 L}{2} = \frac{I_m^2 L \cos^2(\omega_0 t + \varphi_0)}{2} = \frac{I_m^2 L}{4} [1 + \cos 2(\omega_0 t + \varphi_0)] \end{aligned} \quad (8.3)$$

As it follows from Equation (8.3) the values of $W_{el}(t)$ and $W_m(t)$ are changing with the frequency $2\omega_0$, which is twice as the self-frequency ω_0 of self-oscillations.

If the active resistance R is included into the oscillatory circuit (see Figure 8.1[b]), the damped oscillations of a charge on the capacitor's plates and damped oscillations of a current in a circuit occur. In this case the differential equation for the charge oscillations is as follows:

$$\frac{d^2 q}{dt^2} + 2\delta \frac{dq}{dt} + \omega_0^2 q = 0. \quad (8.4)$$

Equation (8.4) has the solution

$$q(t) = q_m e^{-\delta t} \sin(\omega t + \varphi_0), \quad (8.5)$$

where $\delta = R/2L$ - is the damping coefficient. The frequency ω and period T of damped oscillations are determined by the following relations :

$$\omega = \sqrt{\omega_0^2 - \delta^2}; \quad T = \frac{2\pi}{\sqrt{\omega_0^2 - \delta^2}}. \quad (8.6)$$

As it follows from Equation (8.6), the frequency of damped oscillations is less than the frequency of free oscillations: $\omega < \omega_0$, while the period of damped oscillations is greater than the period of free oscillations, $T > T_0$. When $R > 2\sqrt{L/C}$, the process of a change of the charge at the capacitor's plates is not the periodic one. Therefore, the discharge of a capacitor in this case is called non-periodic one. In comparison to free oscillations, now the maximal values of a charge at capacitor's plates exponentially decrease in time, i.e. $q_m \rightarrow q_m \exp(-\delta t)$, see Figure 8.1(e). The time dependence of the current in the contour consisting of an active resistance R is described now by equation:

$$I = I_m e^{-\delta t} \sin(\omega t + \varphi_0 + \Psi),$$

where $\pi/2 < \Psi < \pi$.

The quantity

$$\kappa = \ln \frac{q(t)}{q(t+T)} = \delta T$$

is called the logarithmic decrement of the damped oscillations. Its physical meaning is that κ determines the number of oscillations during the time when the maximal value of the charge at the capacitor's plate is decreased by $e = 2.71...$ times. Another quantity, which is often used to characterize the damped oscillations, is the quality factor (Q-factor) of a circuit. It is defined as

$$Q = \frac{\pi}{\kappa} = \frac{1}{R} \sqrt{\frac{L}{C}}.$$

In order to obtain the continuous (or self-sustained) oscillations in a dissipative system, one uses the external energy source in a special way, when the system itself operates the income of the energy from external source at the necessary time moment. These oscillations are called the continuous oscillations (self-sustained oscillations). For example, in order to support the continuous oscillations in an electrical circuit, it can be linked in a special way to anode circuit of the electronic lamp, see Figure 8.2. Here, the voltage from a circuit is directed through the connecting coil (CC) to the lamp grid G in order to operate an anode current. The basis of this method using for getting the self-sustained oscillations is the principle, which is called the principle of reverse coupling. The same principle governs the work of transistor-based systems for the generation of continuous oscillations.

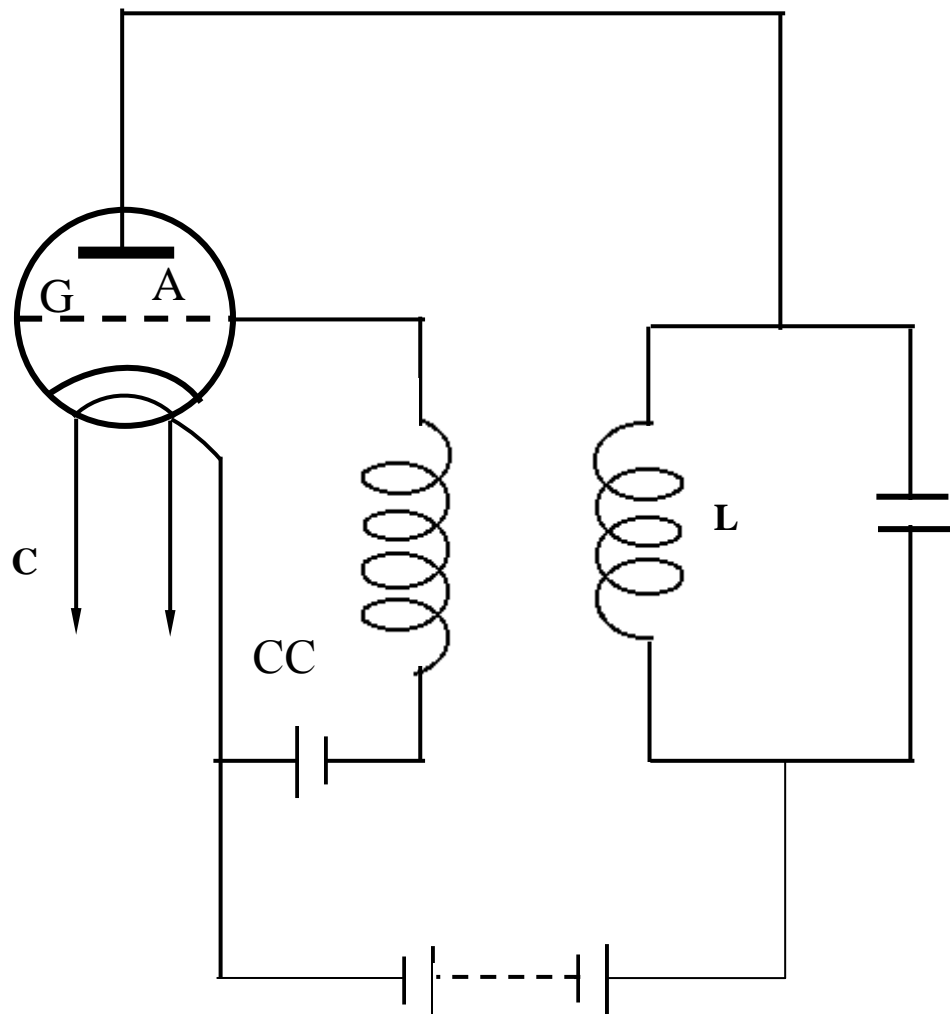

Figure 8.2

Another way to generate continuous oscillations is the inclusion into a circuit of the electromotive force, which is characterized by its own frequency, i.e. $\varepsilon = \varepsilon_m \sin(\Omega t)$, see Figure 8.1(g). The oscillations in this circuit are governed by the

differential equation of forced (induced) electromagnetic oscillations, which has the form:

$$\frac{d^2 q}{dt^2} + 2\delta \frac{dq}{dt} + \omega_0^2 q = \varepsilon_m \sin(\Omega t) . \quad (8.7)$$

The solution of Equation (8.7) is

$$q(t) = q_m e^{-\delta t} \sin(\omega t + \varphi) + q_m \sin(\Omega t + \Psi) . \quad (8.8)$$

Figure 8.1(g) shows the dependence $q(t)$. The second term in Equation (8.8) determines the change of the charge q at the capacitor plates under established forced oscillations, i.e. at $\delta t \gg 1$.

Under a regime of steady-state oscillations the current in a circuit is

$$I = I_m \sin(\Omega t + \alpha) , \quad (8.9)$$

with

$$I_m = \frac{\mathcal{E}_m}{\sqrt{R^2 + \left(L\Omega - \frac{1}{\Omega C}\right)^2}} ;$$

$$\alpha = \text{arctg} \left(\frac{\frac{1}{\Omega C} - \Omega L}{R} \right) . \quad (8.10)$$

The formulae (8.10) determine the maximal value of the current strength I_m in a circuit and the phase shift between the current strength and applied electromotive force $\varepsilon = \varepsilon_m \sin(\Omega t)$. The value

$$Z = \sqrt{R^2 + \left(L\Omega - \frac{1}{\Omega C}\right)^2}$$

is named the total resistance (or impedance) of an oscillatory circuit. Here, R is the active (ohmic or DC) resistance, $R_L = L\Omega$ - is the inductive reactance and $R_C = 1/\Omega C$ is the capacitive reactance. If the total resistance or impedance is only the inductive reactance, it shifts the phase of applied alternating current in an oscillatory circuit by the value $\alpha = -\pi/2$ compared to the phase of applied electromotive force $\varepsilon = \varepsilon_m \sin(\Omega t)$. If the total resistance (impedance) is only the capacitive reactance, it shifts the same phase of applied alternating current by the value $\alpha = +\pi/2$ compared to the phase of applied electromotive force.

In accordance with the first of two Equations (8.10), the amplitude of the current strength I_m in an oscillatory circuit strongly depends on the forcing frequency Ω (see Figure 8.3).

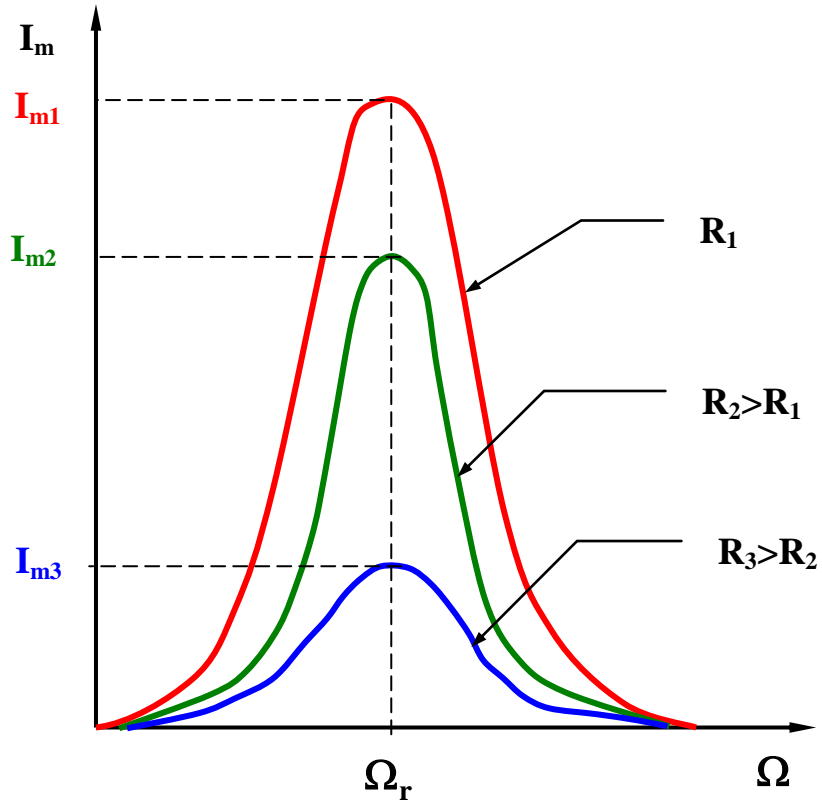

Figure 8.3

The curves presenting $I_m = I_m(\Omega)$ are called the resonance curves. The maximal value of the current strength in an oscillatory circuit $I_{\max} = \varepsilon_m / R$ is achieved at the forcing frequency $\Omega = \Omega_{res} = 1/\sqrt{LC}$. The value Ω_{res} is called the resonant frequency of forced oscillations. The rapid increase of the current strength amplitude in a circuit at $\Omega \rightarrow \Omega_{res}$ is called the resonance. At resonance, the amplitudes of voltage decrease U_{mL} at the inductivity L and U_{mC} at the capacity C are equal, but their phases are opposite: U_{mL} overtakes U_{mC} in phase by π . Under the resonance the total voltage drop in a circuit equals the voltage drop at the active resistance (this case is named the case of the resistances resonance). If in a circuit the inductivity L and capacity C are connected in parallel, then the resonance of the currents occurs which results in a drastic decrease of the current strength in an external circuit at $\Omega \rightarrow \Omega_{res}$.

7.2. Electromagnetic Waves

As it was shown in Section 8.1, the self-frequency of electromagnetic oscillations in an oscillatory circuit equals $\omega_0 = 1/\sqrt{LC}$. As a sequence, by decreasing of the capacity C , e.g. increasing the distance between a capacitor plates (see Figure 8.4[a]) the ω_0 value increases. Increasing this distance, one can obtain an open oscillatory circuit (see Figure 8.4[b]). In this case the electromagnetic oscillations can propagate in a space. The alternating electromagnetic fields propagating in a space are called the electromagnetic waves.

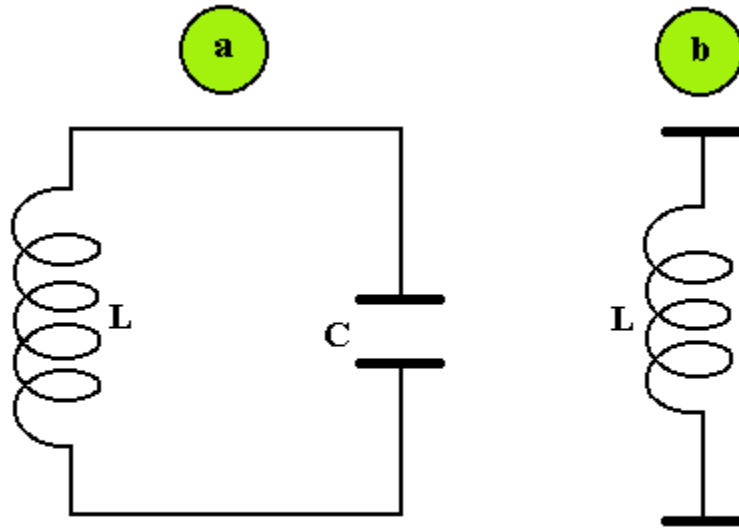

Figure 8.4

H.Hertz was the first who experimentally studied the electromagnetic waves. In an experiment he used an open oscillatory circuit, which consisted of two rods with equal concentrated capacity (made as a ball) placed at the end of each rod, and the balls were divided by a spark gap in the middle. The alternating voltage was applied to this gap. This setup is named Hertz's vibrator. Hertz's vibrator generates the electromagnetic waves of frequencies in the range $10^5 \div 10^{10} Hz$ (radio-waves), which penetrate through the optical medium similarly to light waves. H.Hertz proved that both reflection and refraction of these electromagnetic waves obey the same laws as for those light waves, which are in the range of frequencies $10^{13} \div 10^{15} Hz$.

The connection between vectors \vec{E}, \vec{H} in the electromagnetic wave penetrating through the non-conductive medium is defined by Maxwell's Equations (7.5), where we have to take $\rho = 0, \vec{j}_{cond} = 0$. Consider the plane electromagnetic wave propagating along the OX axis ($E_z = 0, H_z = 0$). Using Equations (7.5), one easily obtains a set of equations, which connect the space and time partial derivatives of different components of \vec{E} and \vec{H} :

$$\begin{aligned}\frac{\partial E_y}{\partial x} &= -\mu_0\mu \frac{\partial H_z}{\partial t}; & \frac{\partial E_z}{\partial x} &= \mu_0\mu \frac{\partial H_y}{\partial t}; \\ \frac{\partial H_y}{\partial x} &= \varepsilon_0\varepsilon \frac{\partial E_z}{\partial t}; & \frac{\partial H_z}{\partial x} &= -\varepsilon_0\varepsilon \frac{\partial E_y}{\partial t}.\end{aligned}\quad (8.11)$$

From the set of Equations (8.11) one obtains the wave equations for the components of the vectors \vec{E} and \vec{H} of the plane electromagnetic wave:

$$\begin{aligned}\frac{\partial^2 E_y}{\partial x^2} &= (\varepsilon_0\mu_0\varepsilon\mu) \frac{\partial^2 E_y}{\partial t^2}; \\ \frac{\partial^2 H_z}{\partial t^2} &= (\varepsilon_0\mu_0\varepsilon\mu) \frac{\partial^2 H_z}{\partial t^2}.\end{aligned}\quad (8.12)$$

The comparison of Equations (8.12) and (7.6) leads to the conclusion that the plane electromagnetic wave can be completely defined using only the vector potential $\vec{\Psi}$.

Indeed,

$$\vec{E} = \frac{1}{\sqrt{\varepsilon_0\mu_0\varepsilon\mu}} [\text{rot}\vec{\Psi}, \vec{k}],$$

here \vec{k} - is the unit vector directed along the propagation of electromagnetic wave. The velocity of this wave is

$$v = \frac{1}{\sqrt{\varepsilon_0\mu_0\varepsilon\mu}}. \quad (8.13)$$

Here, $1/\sqrt{\varepsilon_0\mu_0} = c = 3 \cdot 10^9 \text{ cm/s}$ is the speed of light in a vacuum. Therefore, the velocity of electromagnetic wave given by Equation (8.13) is rewritten now in the form:

$$v = \frac{c}{\sqrt{\varepsilon\mu}} = \frac{c}{n}, \quad (8.14)$$

where n - is the refractive index of a medium through which an electromagnetic wave propagates. The coincidence of Equation (8.14) with similar equation in the optics let us make a conclusion (J.C.Maxwell): the light waves are the electromagnetic waves. From Equations (8.12) it follows also that the vectors \vec{E} and \vec{H} are mutually perpendicular and are perpendicular to the velocity vector \vec{v} of a wave, see Figure 8.5. Therefore, the light is the electromagnetic transverse waves. In these waves the vectors \vec{E} , \vec{H} always oscillate in the same phases, and their values at the arbitrary point of a space are connected through equation

$$\sqrt{\varepsilon_0 \varepsilon} E = \sqrt{\mu_0 \mu} H .$$

The energy of an electromagnetic wave is a sum of energies of alternating electric and magnetic fields. The volume energy density W of the electromagnetic wave is determined by an equation

$$W = \frac{1}{2} \varepsilon_0 \varepsilon E^2 + \frac{1}{2} \mu_0 \mu H^2 = \sqrt{\varepsilon_0 \mu_0 \varepsilon \mu} E \cdot H = \frac{1}{v} E \cdot H . \quad (8.15)$$

The vector $\vec{S} = \vec{v}W = [\vec{E}\vec{H}]$ determines the direction of electromagnetic energy flux density and is named the Poynting's vector.

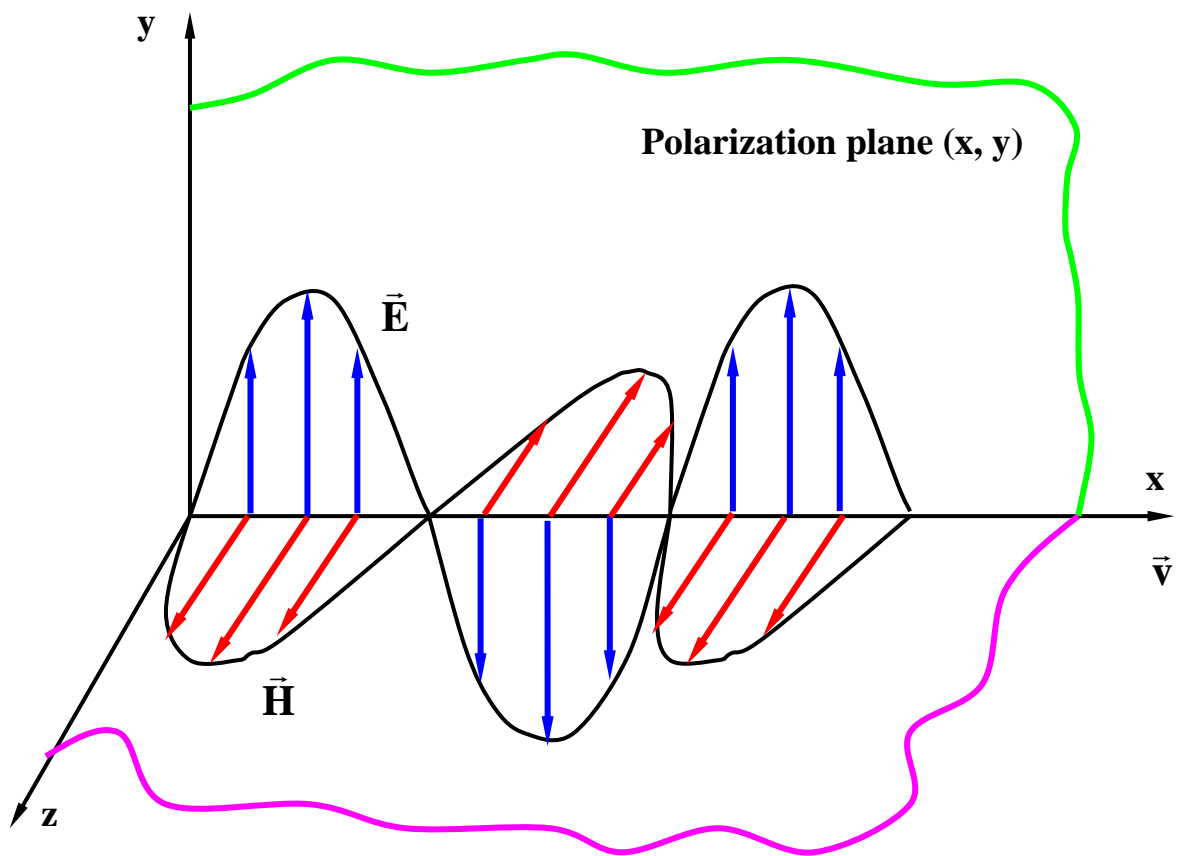

Figure

The spectrum of electromagnetic waves is very broad. It consists of the following ranges: radio waves (the frequencies $\nu = 10^5 \div 10^{11} \text{ Hz}$), light waves including infrared, visible and ultraviolet ones ($\nu = 10^{11} \div 10^{17} \text{ Hz}$), X-rays ($\nu = 10^{17} \div 10^{19} \text{ Hz}$), and γ -radiation ($\nu > 10^{19} \text{ Hz}$). This conventional division into the ranges is called the scale of electromagnetic waves. The Table 1 presents the scale of

electromagnetic waves. Each range is characterized both by a wavelength, by a frequency ν and by an energy $\hbar\omega$ of the photon. The concept of a photon is necessary in quantum optics and is considered in details in the Physics–III. In quantum optics, the electromagnetic wave is associated with a flux of the specific particles, which have zero mass and are moving with the light velocity.

Table 1

	Radio waves	Light waves			X-Rays	γ - radiation
		Infrared	Visible	Ultraviolet		
Wavelength, m	$\geq 5 \cdot 10^{-5}$	$10^{-6} \div 10^{-2}$	$0.38 \cdot 10^{-6} \div 0.77 \cdot 10^{-6}$	$10^{-8} \div 0.38 \cdot 10^{-6}$	$10^{-7} \div 10^{-10}$	$\leq 10^{-10}$
Frequency ν, Hz	$\leq 6 \cdot 10^{12}$	$10^5 \div 10^{11}$	$10^5 \div 10^{11}$	$10^5 \div 10^{11}$	$10^5 \div 10^{11}$	$10^5 \div 10^{11}$
Photon energy $\hbar\omega$, eV	$10^{-4} \div 10^{-2}$	$10^{-2} \div 10^1$	$10^1 \div 10^2$	$10^2 \div 10^3$	$10^3 \div 10^5$	$10^5 \div 10^9$

The radio waves are usually generated by the open oscillatory circuits (antennas) and these electromagnetic waves are widely applied in science and technology, e.g. in radio connection, television, radiolocation and radio astronomy.

The light waves are connected with emission of electromagnetic waves by the excited atoms. In particular, the infrared electromagnetic waves (infrared radiation) are a long-wave part of the broad spectrum of electromagnetic waves emitted by the heated bodies. The modern physics uses the powerful sources of coherent and monochromatic light sources, which are named lasers. The lasers are widely applied in science and industry, in modern electronics and computers.

The X-Rays (discovered by the German physicist W.K.Roentgen in 1895) are connected with the emission of the short-wavelength electromagnetic waves by atomic nuclei during radioactive decays and are also generated by relativistic electrons (positrons) passing through a matter or moving in a circle in a synchrotron (see, Sec.5.3) or through periodic electric or magnetic fields. The X-Rays are widely used in medicine and in material research.

The γ - radiation occurs during nuclear reactions, particles decays and also during passage of relativistic electrons through a matter. This kind of electromagnetic radiation is used in nuclear physics to study the properties of atomic nuclei and to investigate so-called photonuclear reactions (reactions induced by gamma-rays interacting with atomic nuclei).