

PARAMETERS AND CYCLES OF WORKING MEDIUM AND COOLANT ON NPP

CONTENTS

- **Initial parameters of steam**
- **Carnot and Rankine cycle on saturated steam**
- **Application of superheated steam on NPP**
- **Intermediate separation of steam**
- **Intermediate superheating of steam**

INITIAL PARAMETERS OF STEAM

Strongly depend on parameters of coolant.

Only general criteria for water coolant –
temperature before turbine is non-critical.

1-CIRCUIT NPP

Coolant – water and steam-water mixture.

Increasing of pressure results in:

- **Increasing of steam parameters (+);**
- **NPP efficiency increases (+);**
- **The thickness of walls of equipment increases (-);**
- **Capital costs increase (-);**
- **Neutron-physical characteristics of reactor decline (-);**
- **The using of fuel with higher enrichment is needed (-).**

1-CIRCUIT NPP

Increasing pressure results in increasing costs due to:

- Larger consumption of zirconium alloys due to increased thickness of walls in reactor;
- Larger consumption of metals due to increased thickness of walls in steam turbine-unit;
- Need for higher enrichment of uranium.

The pressure drop between turbine and reactor should be taken into account.

Example: if water in reactor operates at pressure at which water boils at 285 °C the parameters for steam turbine-unit will be 6,5 MPa and 280 °C.

Based on practical technic-economic calculation the optimal pressure in reactor of 1-circuit NPP is found to be 7 MPa.

2-CIRCUIT NPP

Coolant and moderator – pressurized water.

Working fluid – saturated steam.

Note. Unlike 1-circuit NPP the alloys of fuel assembly doesn't undergone the pressure drop which depend on coolant pressure.

Theoretical maximal pressure 22 MPa is taken according to triple point of water. Based on combined conditions of casing mechanical strength and cost, maximal coolant pressure is found to be 16 MPa.

2-CIRCUIT NPP

Optimal coolant temperature drop: 25-40 °C.

Needed temperature difference in steam generator: 10-15 °C.

The safety margin: 15-25 °C.

Resulting saturation temperature: 260-290 °C corresponds to pressure range 5-7 MPa.

Optimal parameters is considered to be 6 MPa and 274 °C.

Increasing pressure is limited by presented above factors. Increasing initial temperature will cause decreasing of pressure which will result in significant efficiency drop.

3-CIRCUIT NPP

Coolant and moderator – melted metal.

Working fluid – suprheated steam.

Addition of the 3rd circuit allowed to decrease the correlation between parameters in reactor and steam-turbine unit.

Further increasing of steam parameters is possible but limited by characteristics of turbine and steam generator materials.

THERMODYNAMIC CYCLES OF NPP

- **Carnot cycle**
- **Rankine cycle**
 - Rankine cycle on saturated steam
 - Rankine cycle on superheated steam
 - Rankine cycle with separation
 - Rankine cycle with intermediate heating

CARNOT CYCLE

The most efficient possible heat engine cycle is the **Carnot cycle**.

1-2 – isentropic expansion

2-3 – simultaneously isothermal and isobaric heat removal

3-4 – isentropic compression

4-1 – simultaneously isothermal and isobaric heat supply

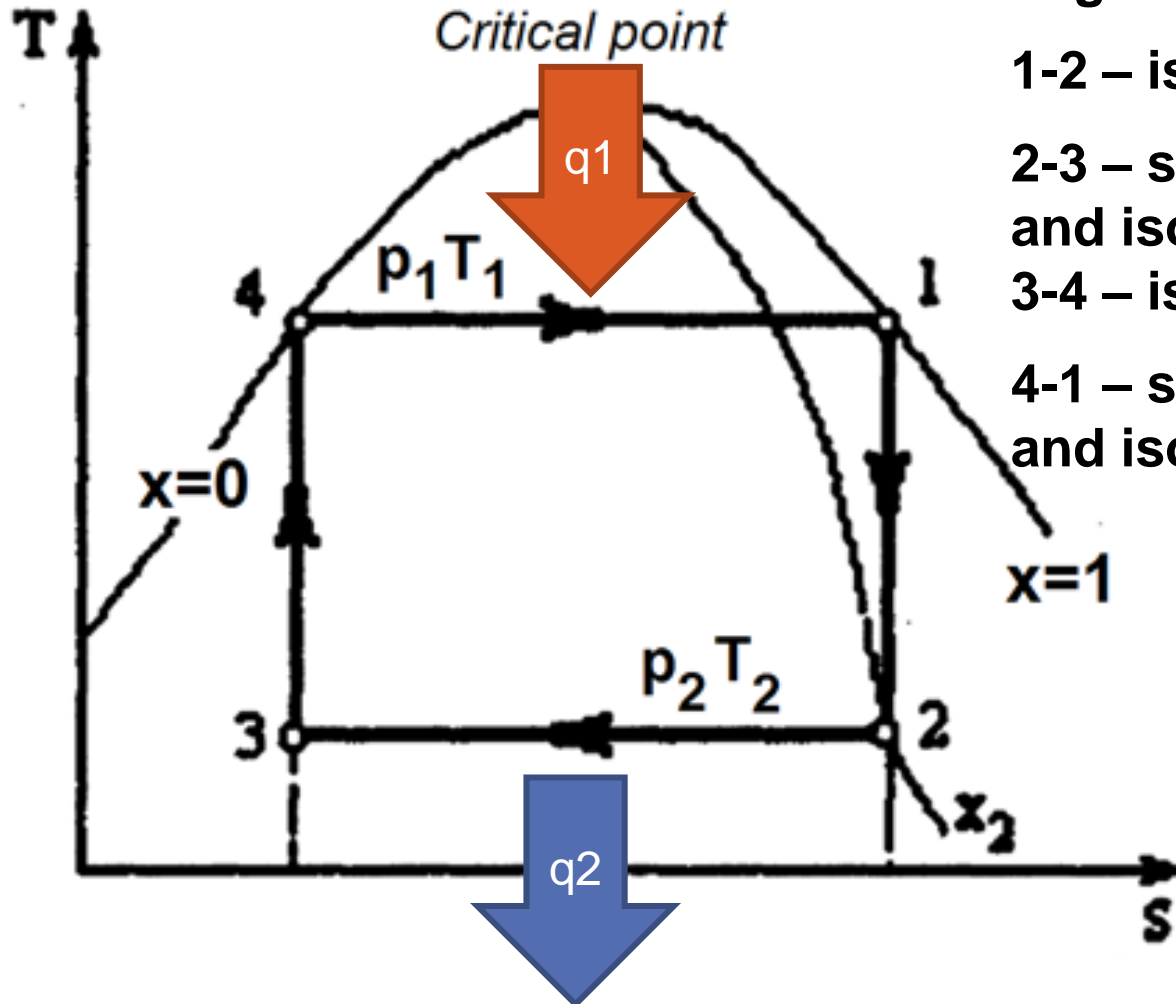

CARNOT CYCLE

The most efficient possible heat engine cycle is the **Carnot cycle**.

1-2 – isentropic expansion

2-3 – simultaneously isothermal and isobaric heat removal

3-4 – isentropic compression

4-1 – simultaneously isothermal and isobaric heat supply

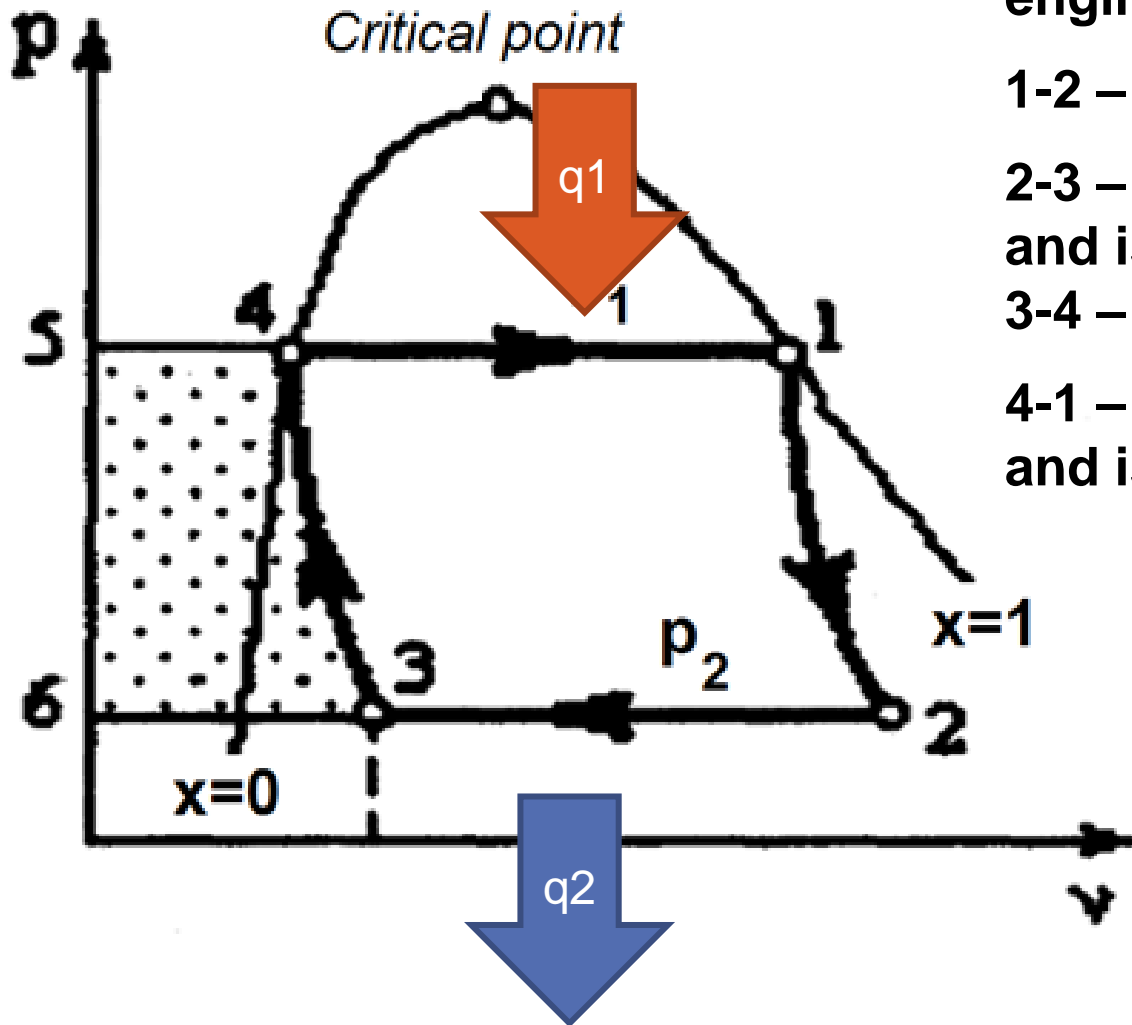

CARNOT CYCLE

Carnot cycle

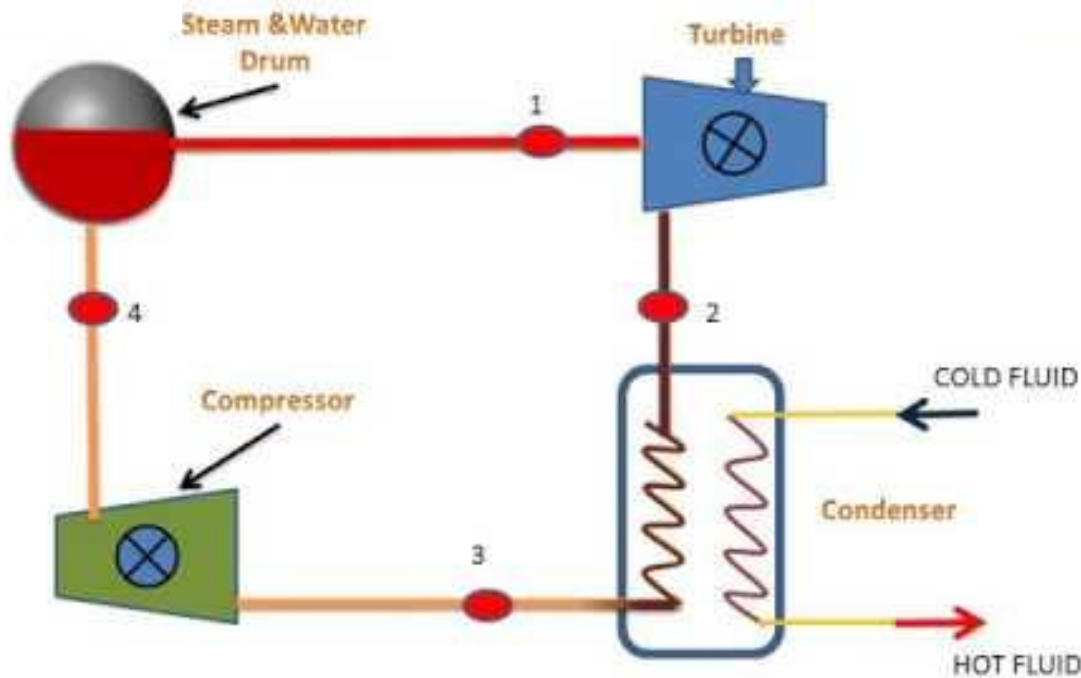

Carnot cycle includes the following equipment:

- **Adiabatic expansion in turbine;**
- **Condensation into condenser;**
- **Adiabatic compression in compressor;**
- **Evaporation into steam generator.**

CARNOT CYCLE

Efficiency of Carnot cycle could be defined as: $\eta_t = 1 - \frac{T_2}{T_1}$

Practical issues with Carnot cycle on saturated steam:

- Need to apply compressor on humid steam for increasing pressure;
- High humidity of steam on the outlet of turbine and compressor;
- Low initial temperatures due to limited initial pressure;
- Low specific work;
- High capital costs;
- High expenses on compression.

No NPP apply Carnot cycle.

RANKINE CYCLE

The Rankine cycle has right part similar with Carnot cycle, but have difference on the left part: adiabatic compression into saturated steam was changed on compression of condensed water.

This resulted into decreased temperature of heat supply into cycle. Despite efficiency of cycle decreased the specific power of cycle increased. The equipment needed for realization of cycle was simplified as well.

RANKINE CYCLE

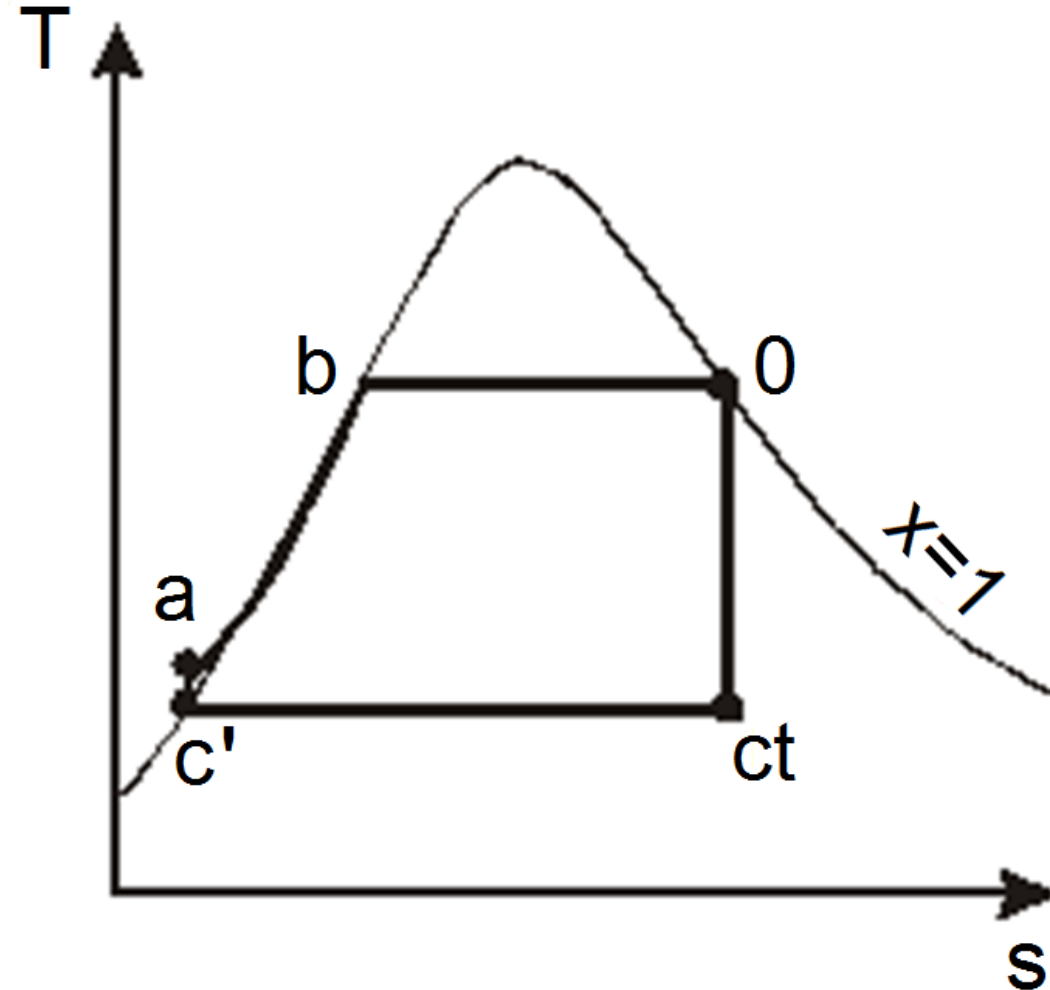

0-ct – isentropic expansion of the steam in a turbine

ct-c' – isobaric heat removal in a condenser, steam returns to liquid

c'-a – isentropic compression of a liquid in a pump

a-b – heating water to a boiling point at $p_0 = \text{const}$

b-0 – boiling water generates steam at $p_0 = \text{const}$ and $T_0 = \text{const}$

RANKINE CYCLE

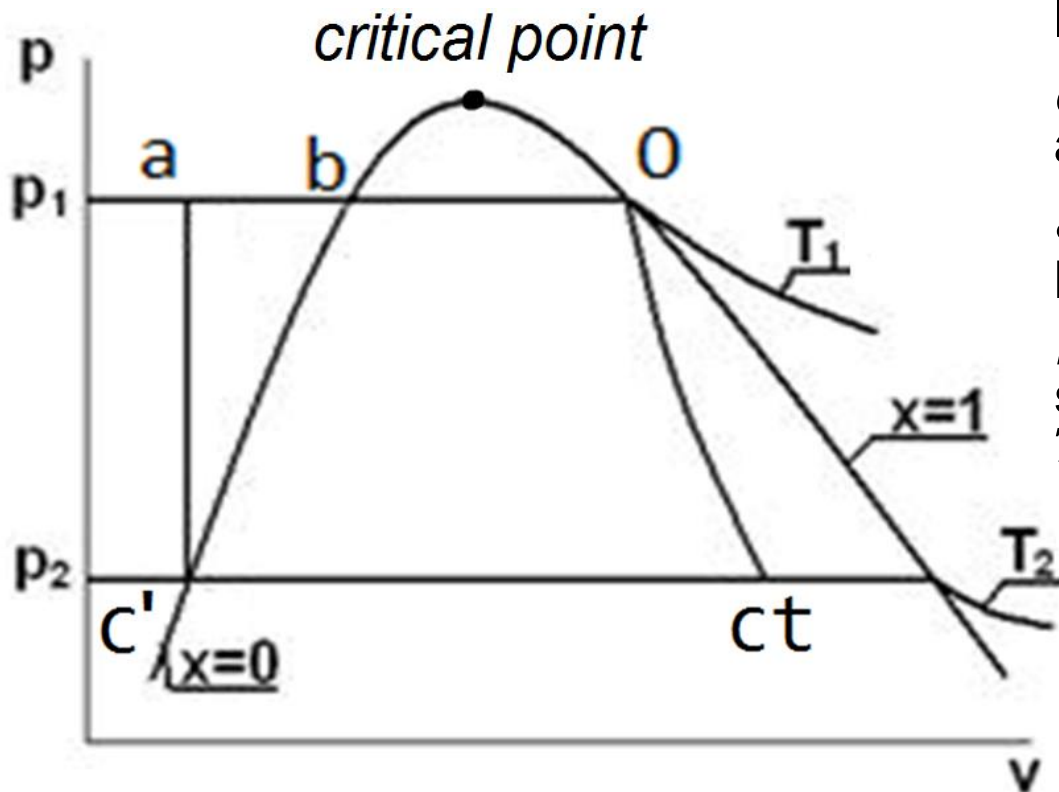

0-ct – isentropic expansion of the steam in a turbine

ct-c' – isobaric heat removal in a condenser, steam returns to liquid

c'-a – isentropic compression of a liquid in a pump

a-b – heating water to a boiling point at $p_0 = \text{const}$

b-0 – boiling water generates steam at $p_0 = \text{const}$ and $T_0 = \text{const}$

RANKINE CYCLE

Efficiency defined as:
$$\eta_t = \frac{(h_0 - h_{ct}) - (h_a - h_{c'})}{h_0 - h_a}$$

Problems:

- High humidity at the end of adiabatic expansion;
- Limited pressure value due to critical point;
- Low specific work;
- Large dimensions of equipment.

Rankine cycle on saturated steam is used for 1-circuit and 2-circuit NPP.

RANKINE CYCLE

To decrease humidity at the end of turbine expansion the steam superheating is applied. This results into increasing efficiency, specific work, but results into need for additional equipment (steam superheating). Separation of steam is also a form of steam superheating.

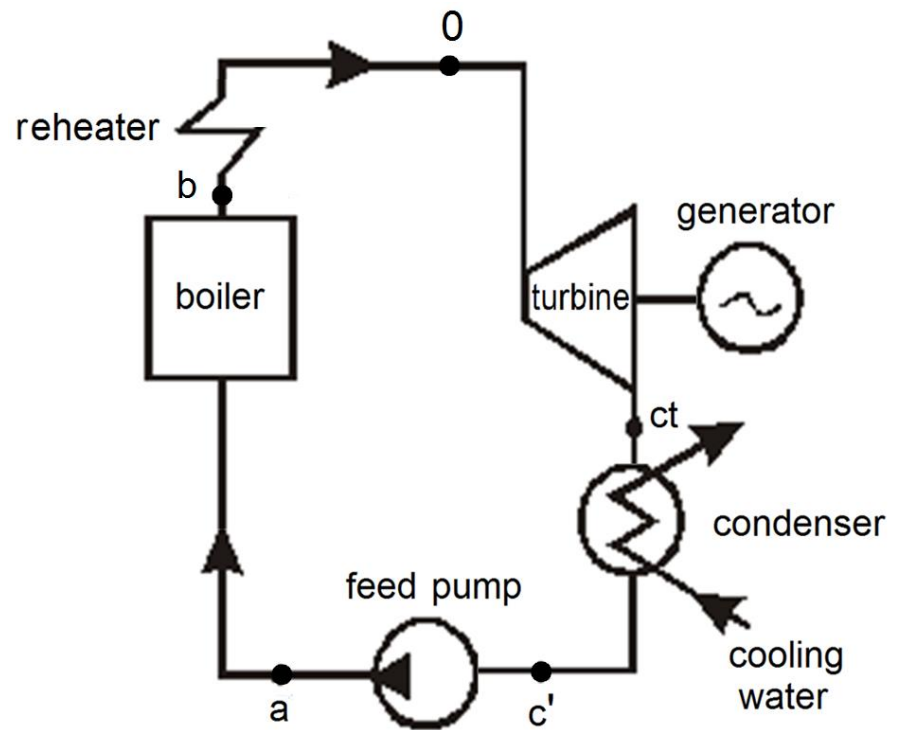
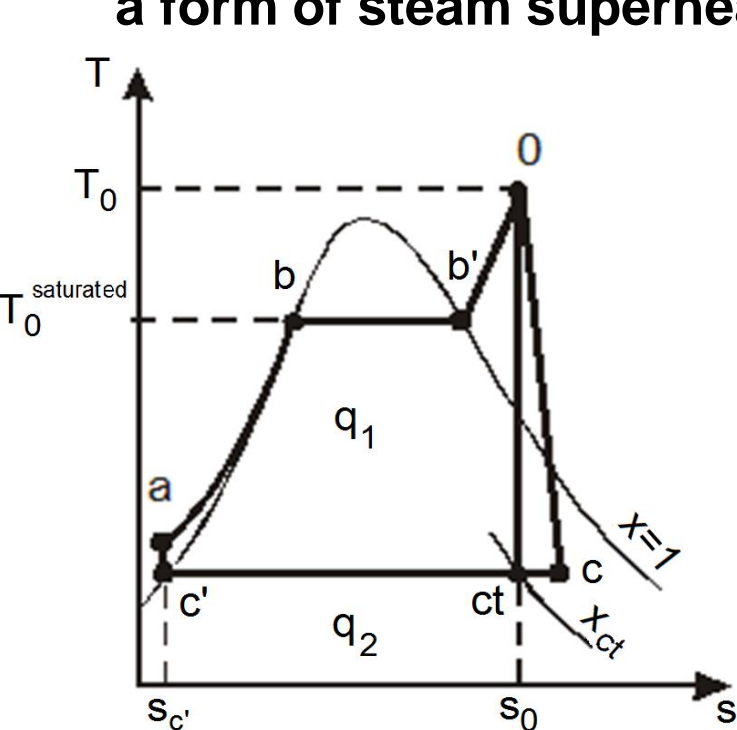

RANKINE CYCLE

To decrease humidity at the end of turbine expansion the steam superheating is applied. This results into increasing efficiency, specific work, decreasing of equipment complexity and costs, but results into need for additional equipment (steam superheating). Separation of steam is also a form of steam superheating.

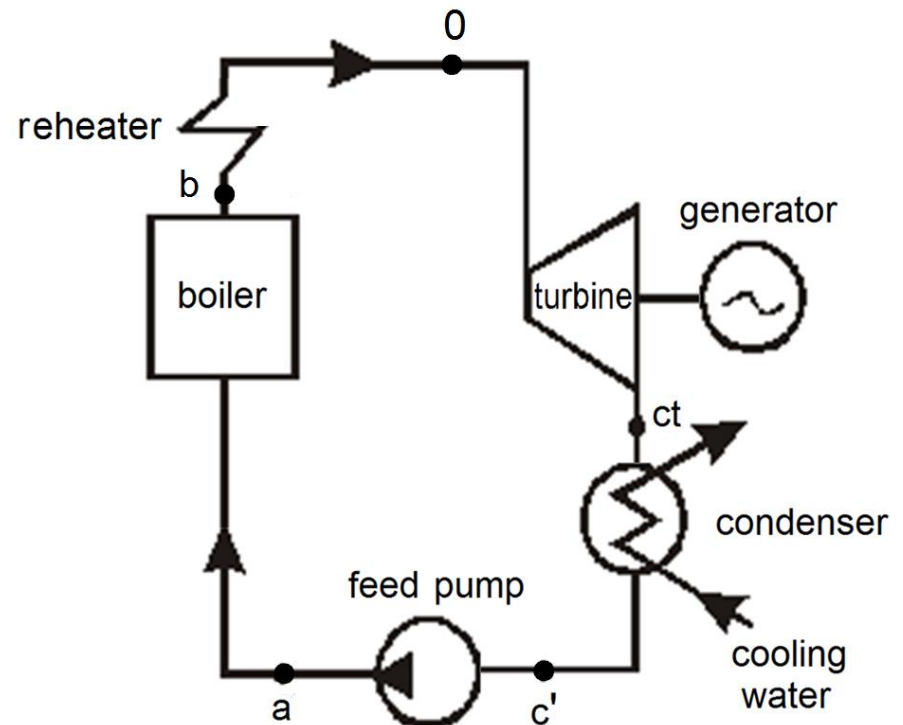
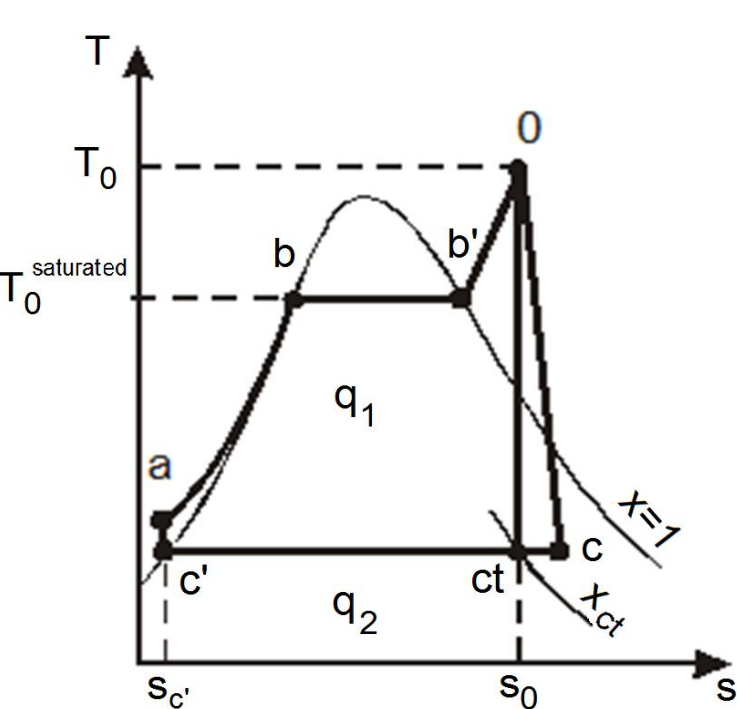

RANKINE CYCLE

Efficiency defined similar with previous cycle:

$$\eta_t = \frac{(h_0 - h_{ct}) - (h_a - h_{c'})}{h_0 - h_a}$$

Superheating by energy from external source always results into increasing efficiency.

The difference between Rankine cycle and Carnot cycle at temperatures t_0 and t_c increases with introduction of superheating.

Parameters of superheated steam is limited by parameters of turbine and superheater.

Rankine cycle on superheated steam is used for 3-circuit NPP.

RANKINE CYCLE

Efficiency defined similar with previous cycle:

$$\eta_t = \frac{(h_0 - h_{ct}) - (h_a - h_{c'})}{h_0 - h_a}$$

Superheating by energy from external source always results into increasing efficiency.

The difference between Rankine cycle and Carnot cycle at temperatures t_0 and t_c increases with introduction of superheating.

Parameters of superheated steam is limited by parameters of turbine and superheater.

Rankine cycle on superheated steam is used for 3-circuit NPP.

RANKINE CYCLE

To decrease humidity of steam at the end of turbine expansion for 1 and 2- circuit stations the separation and reheating by fresh or bleed steam could be applied. Usually these solutions and equipment applied in presented priority until reaching dryness higher than 96 %.

Superheating for 1 and 2- circuit NPP is achievable by decreasing pressure but this cause significant decrease in efficiency.

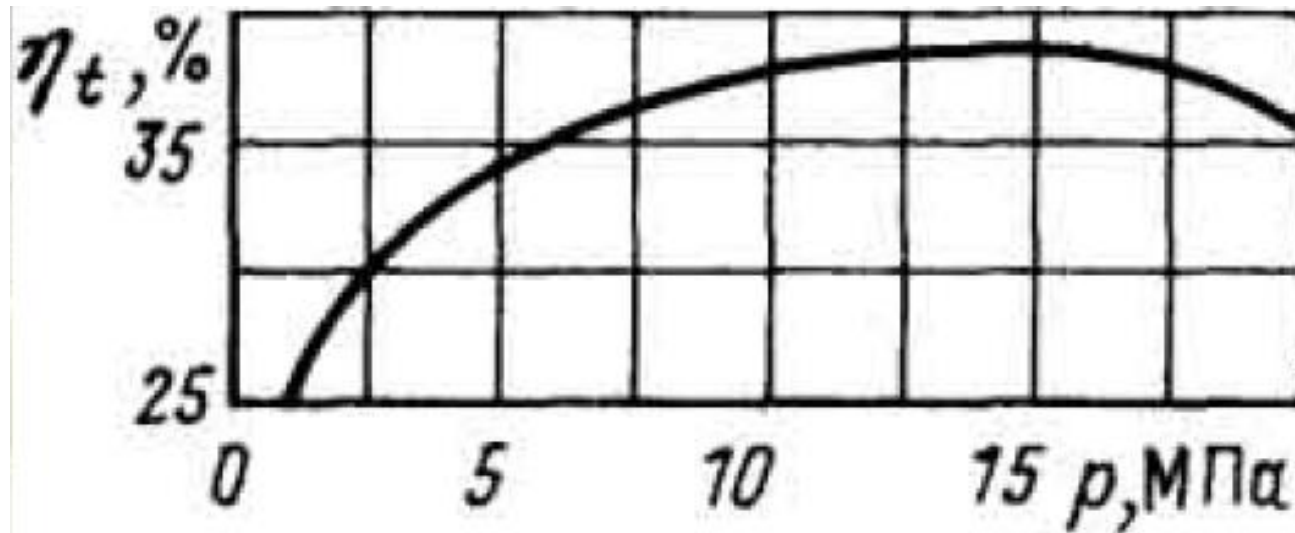

INITIAL PARAMETERS IN NPP

Initial pressure on the inlet of steam turbine:

- **1-circuit NPP – 6,4 MPa;**
- **2-circuit NPP – 4-6 MPa.**

Initial temperature on the inlet of steam turbine:

- **1-circuit NPP – 280 °C;**
- **2-circuit NPP – 255-275 °C.**

Diagram of NPP with moisture separator

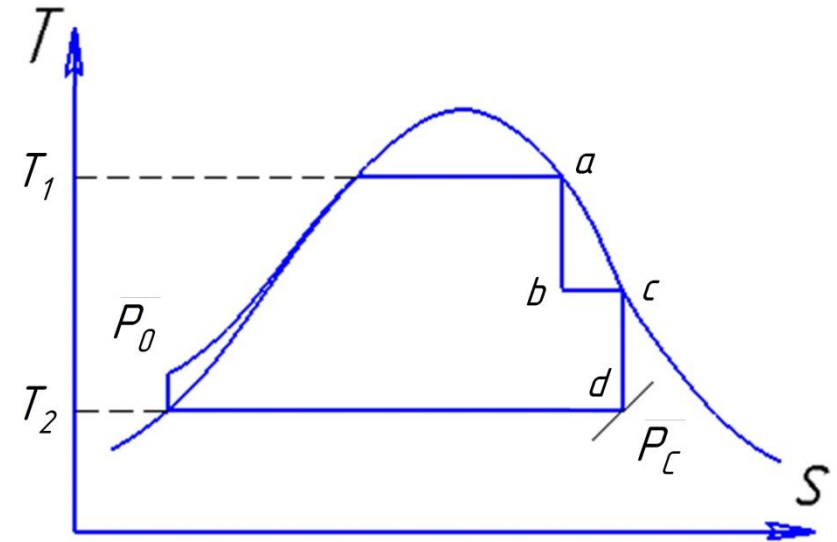
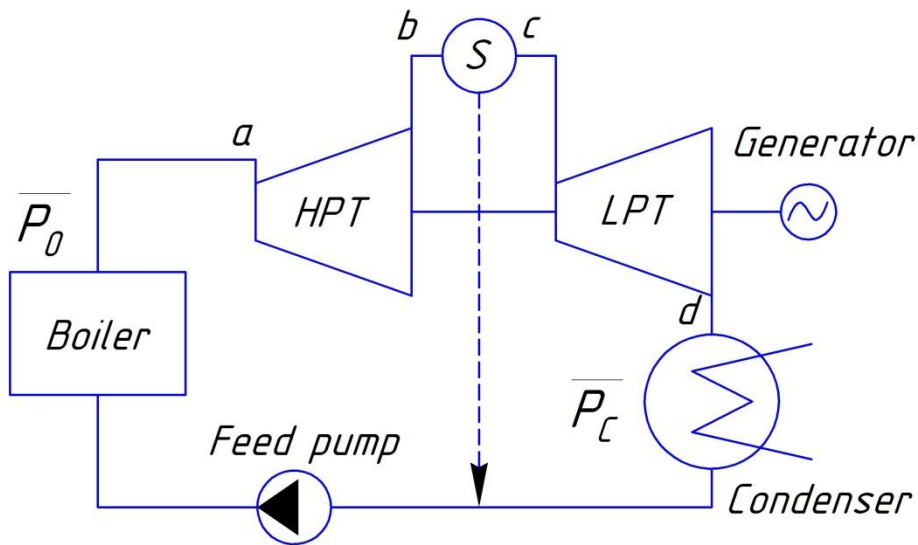

Coefficient of separation:

$$\gamma = \frac{\Delta y}{y_0} = \frac{x_c - x_b}{1 - x_b}$$

$$\gamma = 0,97 - 0,99$$

HPT – High Pressure Turbine
LPT – Low Pressure Turbine
S – moisture separator

Superheating of working body by separation always results into **increasing of the efficiency and specific work.**

Diagram of NPP with a moisture separator and two reheaters

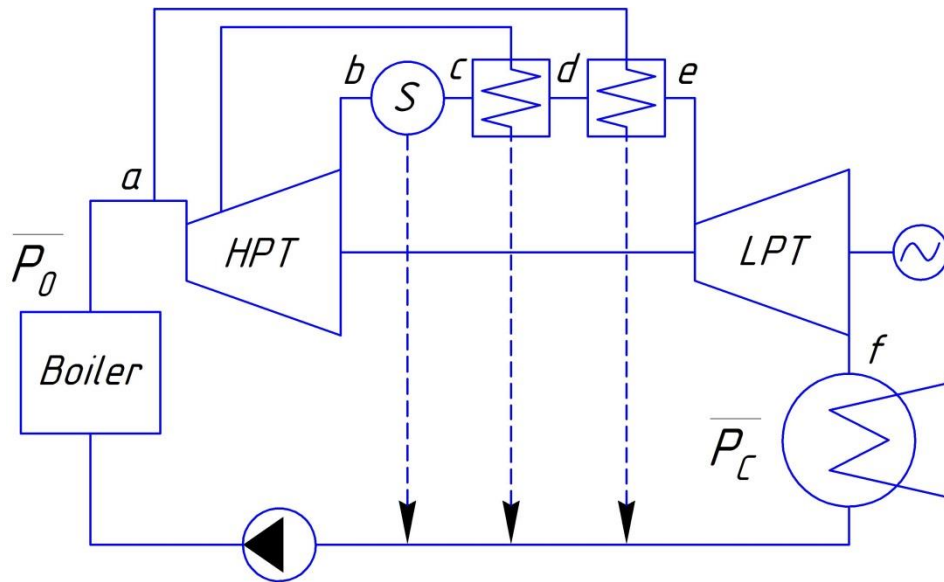

HPT – High Pressure Turbine
LPT – Low Pressure Turbine
S – moisture separator

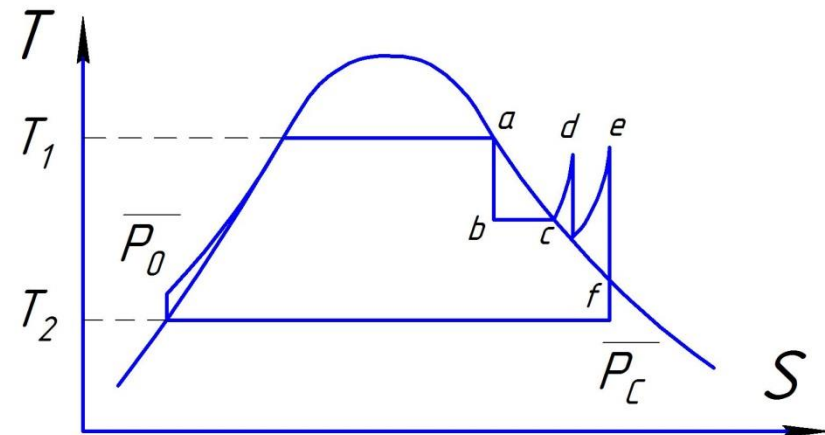

Efficiency of two stage reheating result into higher efficiency in comparison with previous solution. But taking pressure drop into superheaters into account the efficiency became much lower and comparable with previous solution.

EFFECT OF INTERMEDIATE PRESSURE

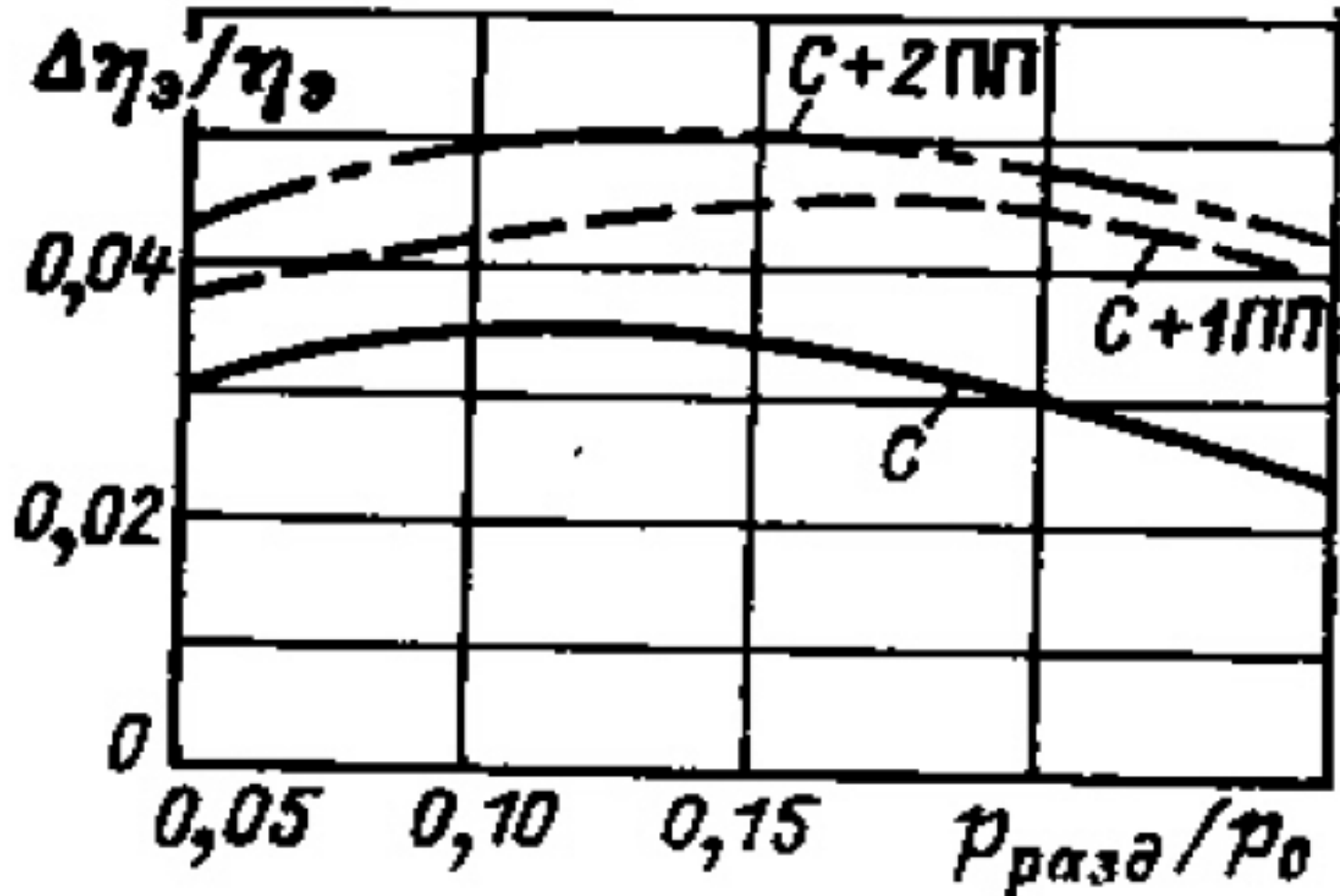

POSSIBLE SCHEMES

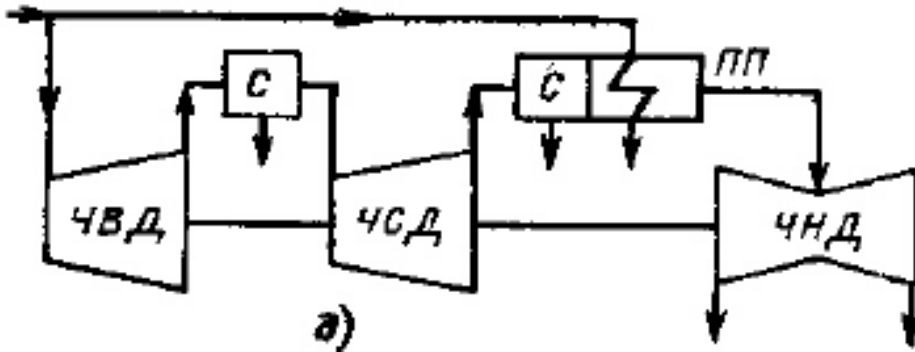
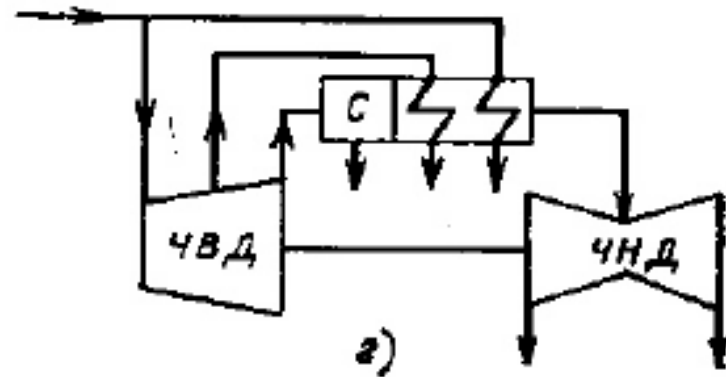
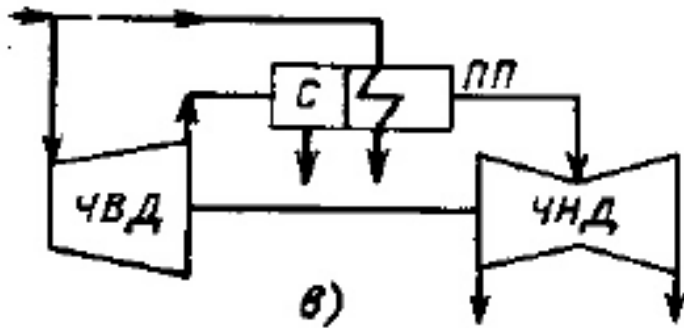
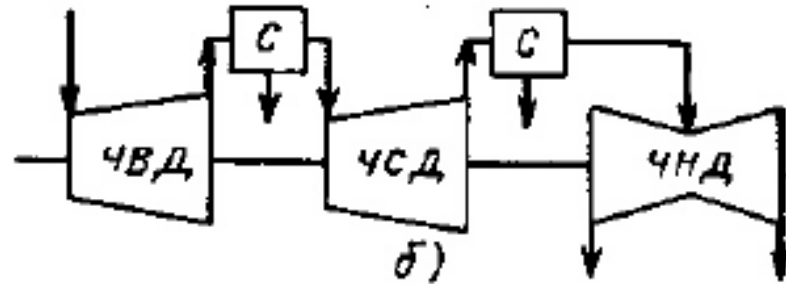
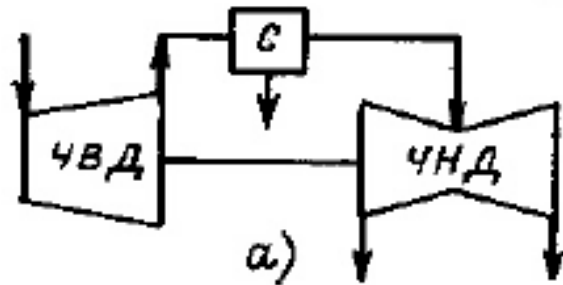

**THANKS FOR
ATTENTION**