

# ELECTRICAL MACHINES

---

Tyuteva Polina Vasilevna,  
PhD, Associate Professor  
Electrotechnical Complexes and Materials,  
Institute of Power Engineering,

8 building, 042 room,  
TyutevaPV@gmail.com

# SYNCHRONOUS MACHINES 1

---

# Synchronous machines

Synchronous motors and generators provide superior value in terms of proven reliability, low maintenance performance and long life in any application. Synchronous machines offer numerous benefits including:

- Constant-speed operation
- High efficiency ratings
- Low inrush currents
- Leading power factor (for corrective KVA capability)

# Construction of Alternator

As stator construction remains the same as in induction machines, there are mainly two types of rotor used in construction of alternators:

- Salient pole type.
- Cylindrical rotor type (non – salient pole).

# Construction of Alternator

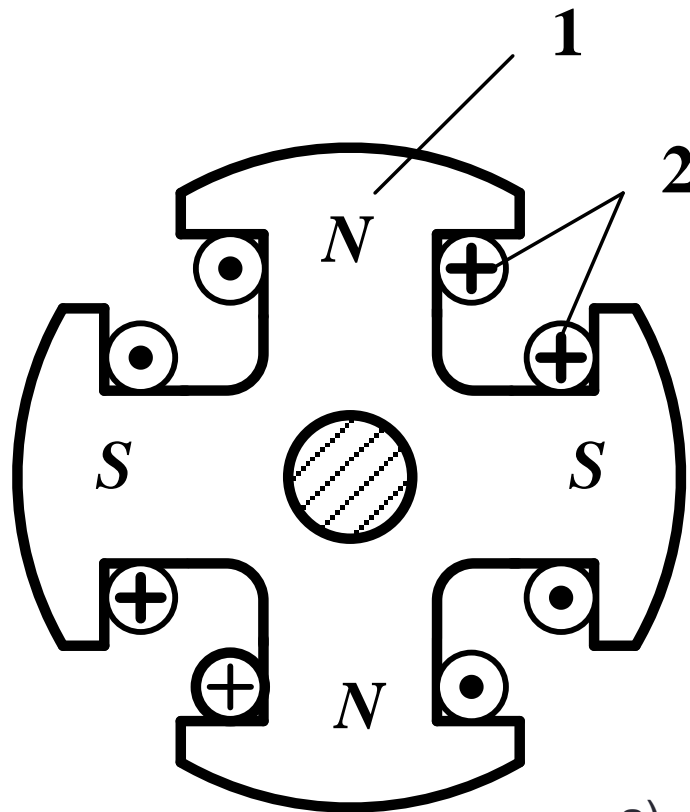

a)

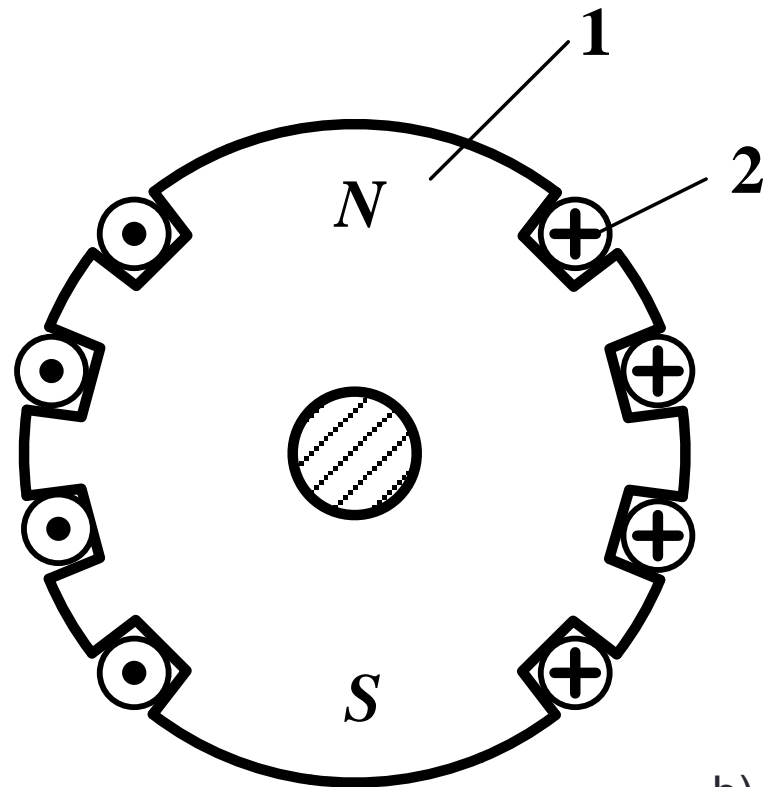

b)

- Salient pole (a) and cylindrical rotor (b) type. 1 – pole, 2 – field or excitation winding

# Cylindrical Rotor Type

- The cylindrical rotor alternators are generally designed for 2-pole type giving very high speed of:

$$n = \frac{60 \cdot f_1}{p} = \frac{60 \cdot 50}{1} = 3000 \text{ rpm.}$$

- Or 4-pole type running at a speed of:

$$n = \frac{60 \cdot f_1}{p} = \frac{60 \cdot 50}{2} = 1500 \text{ rpm,}$$

- where  $f_1$  is the current frequency of 50 Hz.

# Cylindrical Rotor Type

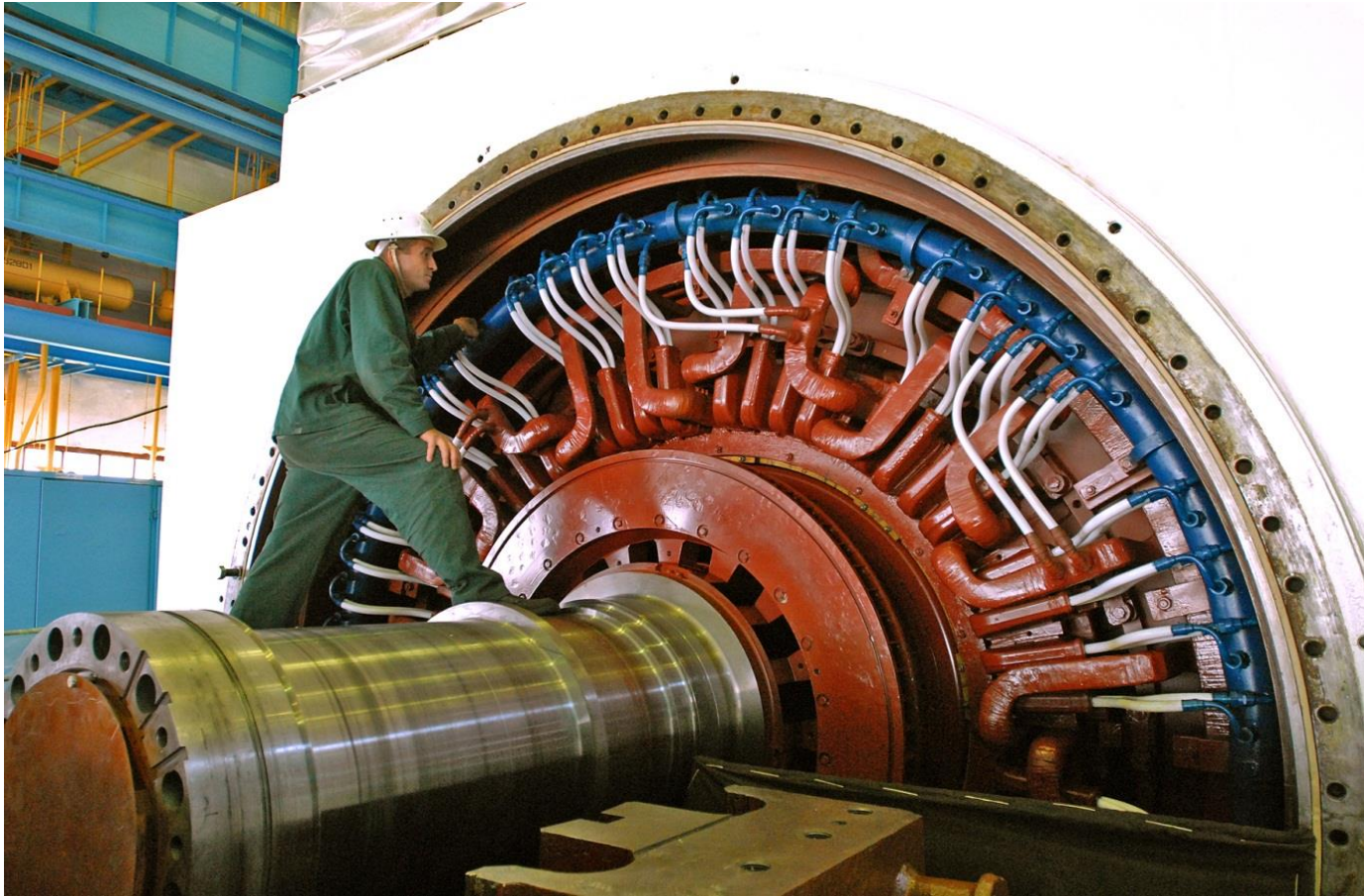

- Turbogenerator

# Cylindrical Rotor Type



- Turbogenerator assembly



# Cylindrical Rotor Type



- Turbogenerator, stator. Silmach

# Salient Pole Type

The salient features of pole field structure has the following special feature:

- large horizontal diameter compared to a shorter axial length.
- the pole shoes covers only about  $2/3rd$  of pole pitch.
- poles are laminated to reduce eddy current loss.

The salient pole type motor is generally used for low speed operations of around 100 to 400 rpm, and they are used in power stations with hydraulic turbines.

# Salient Pole Type



- Hydrogenerator. Chat falls power station, Canada

# Salient Pole Type



- Hydrogenerator, stator. Chat falls power station, Canada

# Salient Pole Type

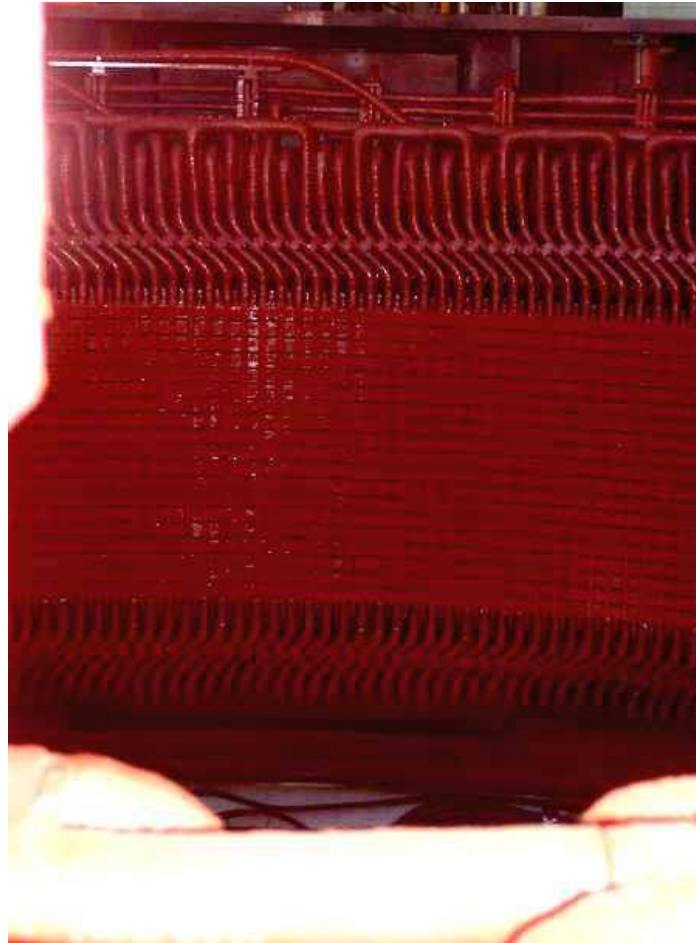

- Hydrogenerator, stator winding. Chat falls power station, Canada

# Salient Pole Type



- Winding on 800 MW hydrogenerator. Alstom

# Salient Pole Type



- Hydrogenerator, salient poles. Chat falls power station, Canada

# Salient Pole Type



- Hydrogenerator, silent poles rotor with field and damper windings.  
Chat falls power station, Canada



# Excitation of synchronous generator

A DC current must be supplied to the field circuit on the rotor. Since the rotor is rotating, a special arrangement is required to get the de power to its field windings. There are two common approaches to supplying this DC power:

- 1. Supply the DC power from an external DC source to the rotor by means of slip rings and brushes.
- 2. Supply the DC power from a special DC power source mounted directly on the shaft of the synchronous generator.

# Working principle of synchronous generator

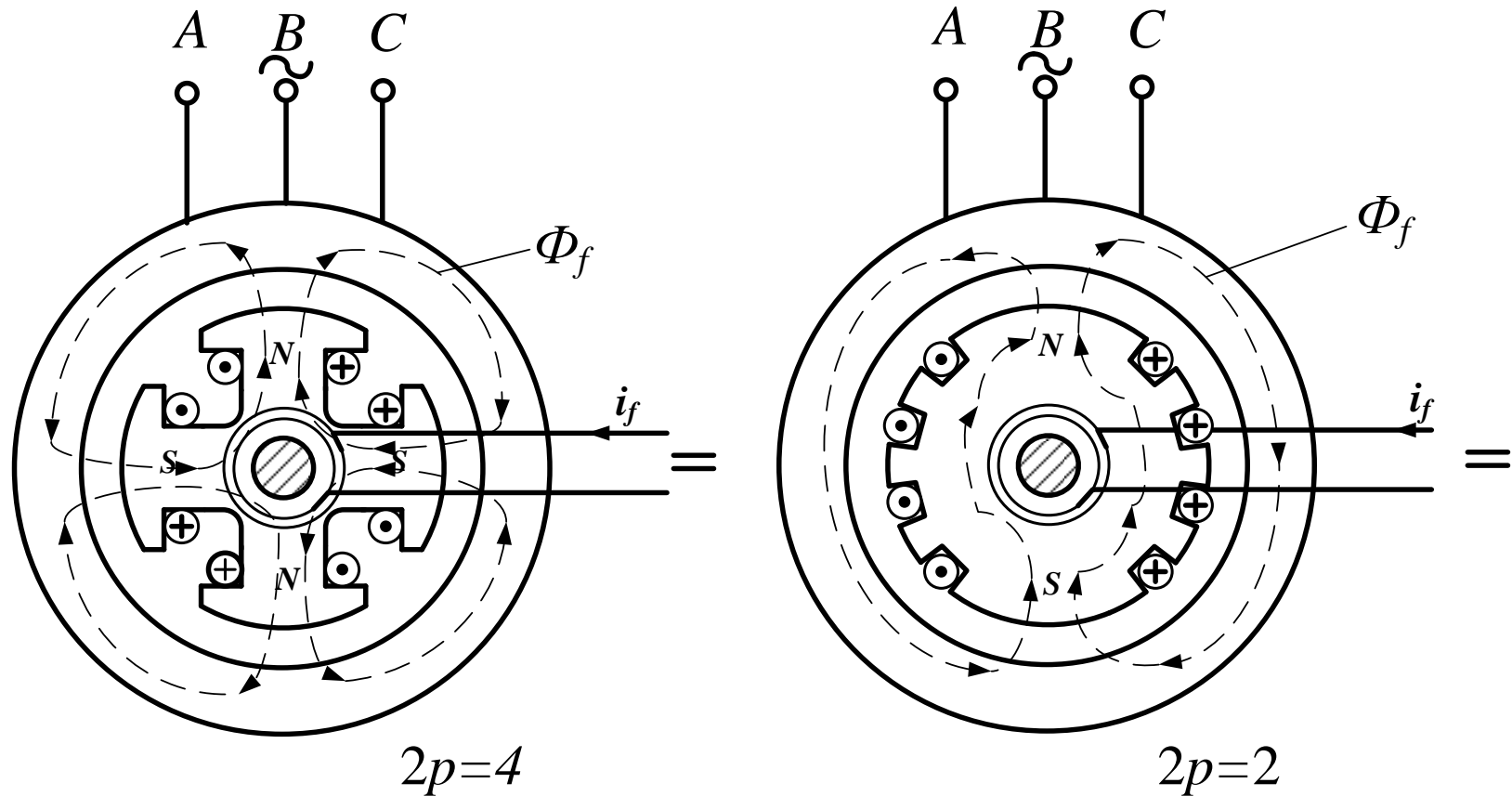

# SYNCHRONOUS MACHINES 2

---

# Armature Reaction in Synchronous Generator

- When the field gets distorted, it is known as **cross magnetizing effect** and
- when the field flux gets reduced, it is known as **demagnetizing effect**.

# Armature Reaction in Synchronous Generator

- The armature reaction of alternator or synchronous generator, depends upon the phase angle between, stator armature current and induced voltage across the armature winding of alternator. The phase difference between these two quantities, i.e. armature current and voltage may vary from  $-90^{\circ}$  to  $+90^{\circ}$ .
- To understand actual effect of this angle on armature reaction of alternator, we will consider three standard cases,
  - 1) When  $\varphi = 0$ .
  - 2) When  $\varphi = +90^{\circ}$ .
  - 3) When  $\varphi = -90^{\circ}$ .

# Armature Reaction of Alternator at Unity Power Factor

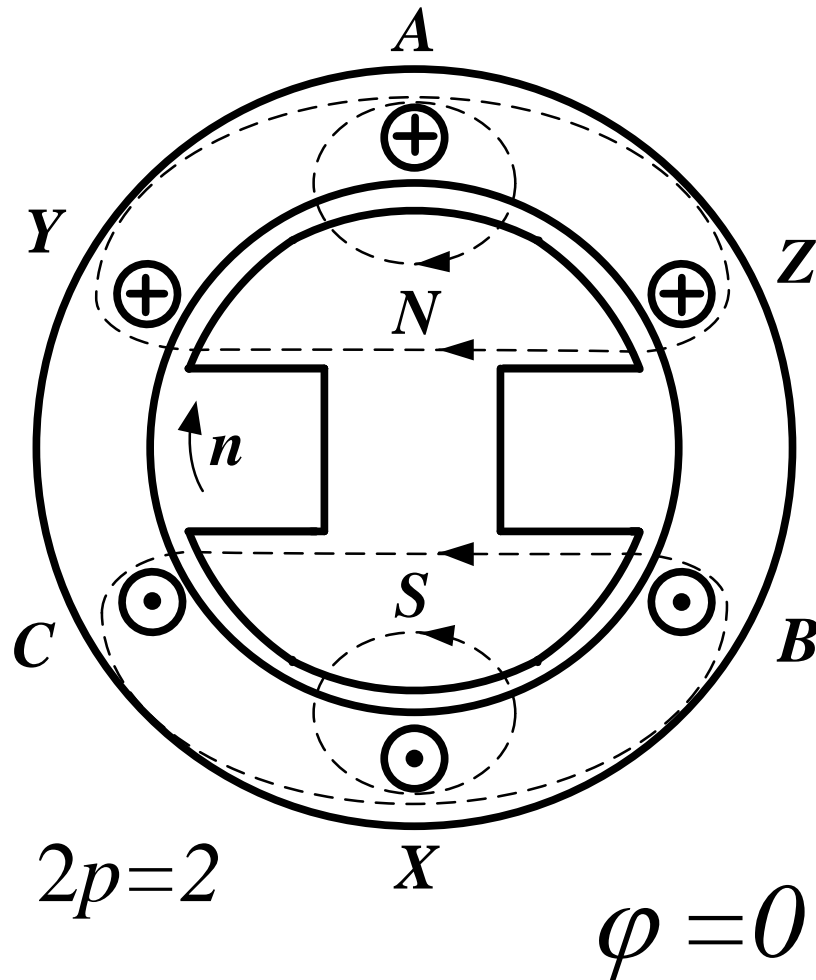

$$i_A = I_{max}$$
$$i_B = i_C = 0,5I_{max}$$

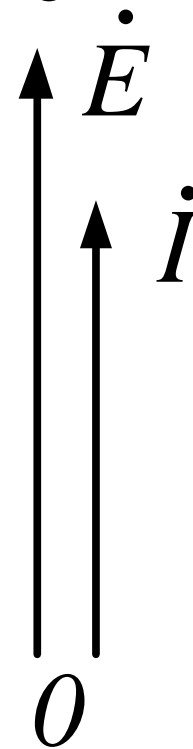

# Armature Reaction of Alternator at Unity Power Factor

- The armature reaction of alternator at unity power factor is purely distorting or **cross-magnetizing type** and have only quadrature-axis components of armature reaction.

# Armature Reaction of Alternator at Lagging Zero Power Factor

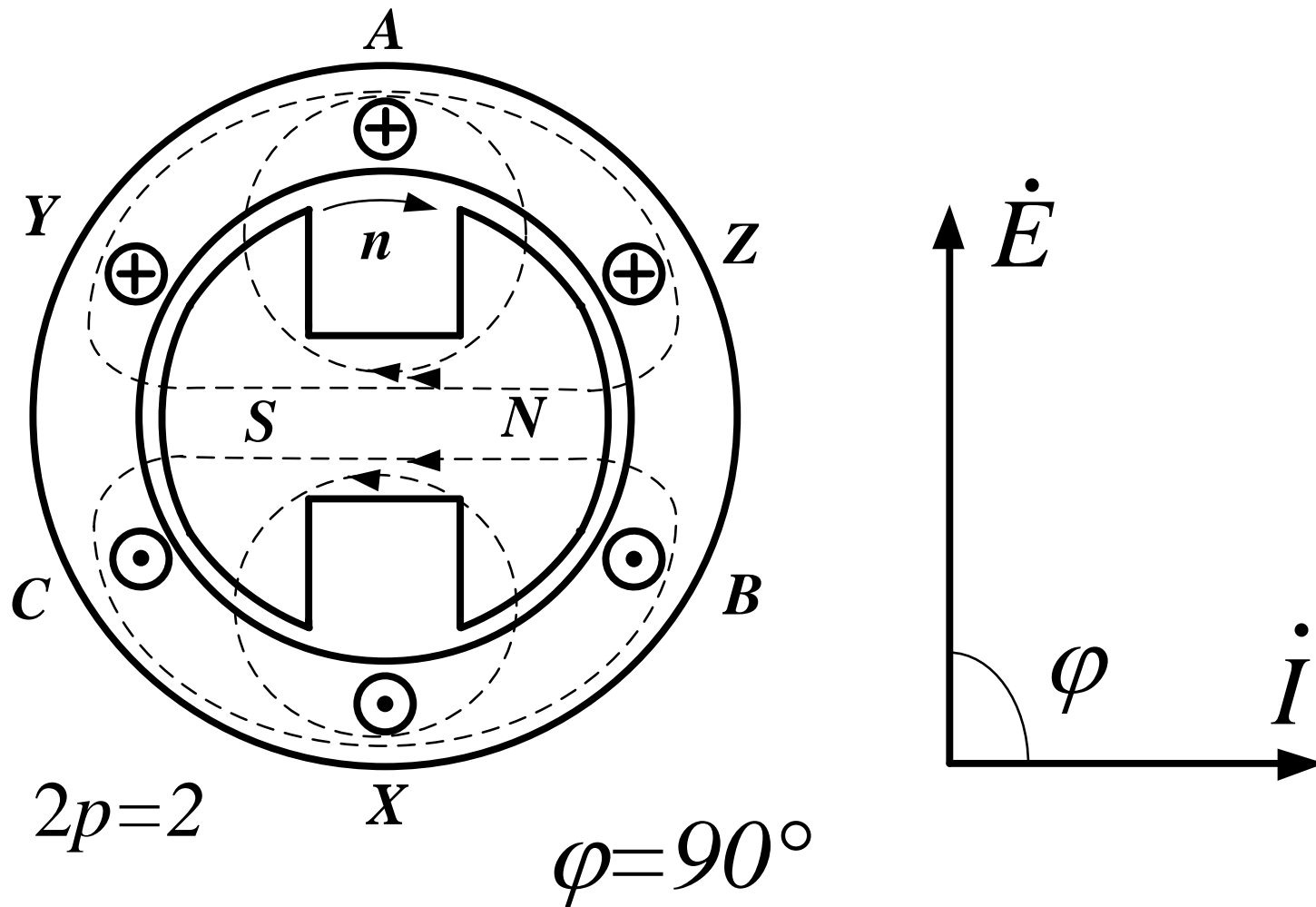



# Armature Reaction of Alternator at Lagging Zero Power Factor

- Armature reaction of alternator at lagging zero power factor is purely **demagnetizing type**. That means, armature flux directly weakens main field flux. Armature reaction has only direct-axis components that weakens main field.

# Armature Reaction of Alternator at Leading Power Factor

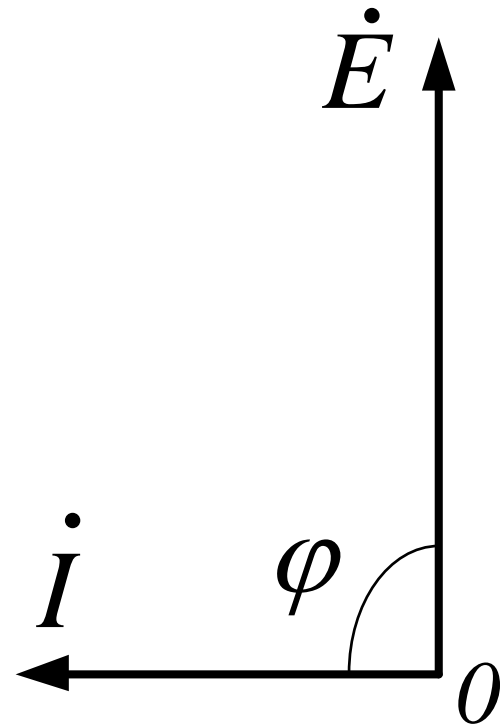
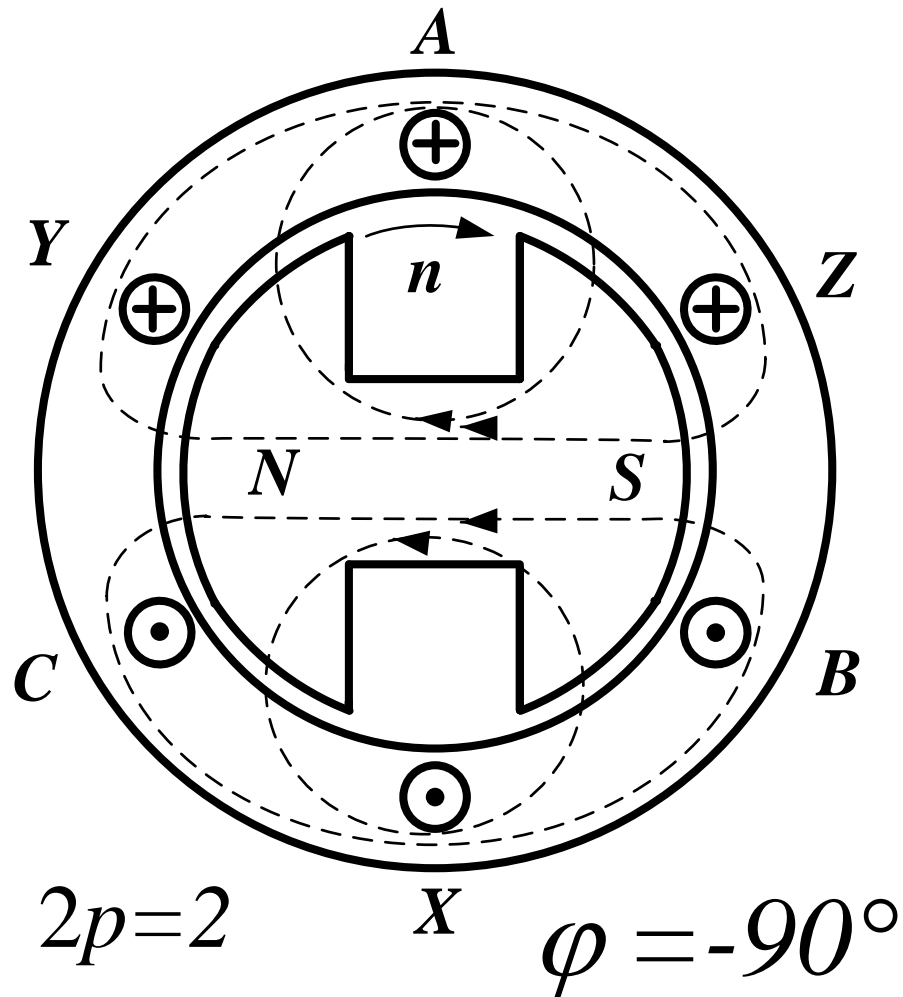

# Armature Reaction of Alternator at Leading Power Factor

- Armature reaction of alternator due to a purely leading electrical power factor is totally **magnetizing type**. Armature reaction has only direct-axis components that magnetizes main field.

# Armature reaction in synchronous generator in case of combined load

- In the case of combined load  $0 < \varphi < 90^\circ$  and armature current could be partitioned into direct-axis component of armature current  $I_d$  and quadrature-axis component of armature current  $I_q$ :

$$I_d = I \sin \varphi, \quad I_q = I \cos \varphi,$$

these components create the direct-axis and quadrature-axis components of armature reaction.

The angle  $\varphi$  has positive value if armature current  $I$  lags the induced EMF  $E$ .

# Armature reaction in synchronous generator in case of combined load

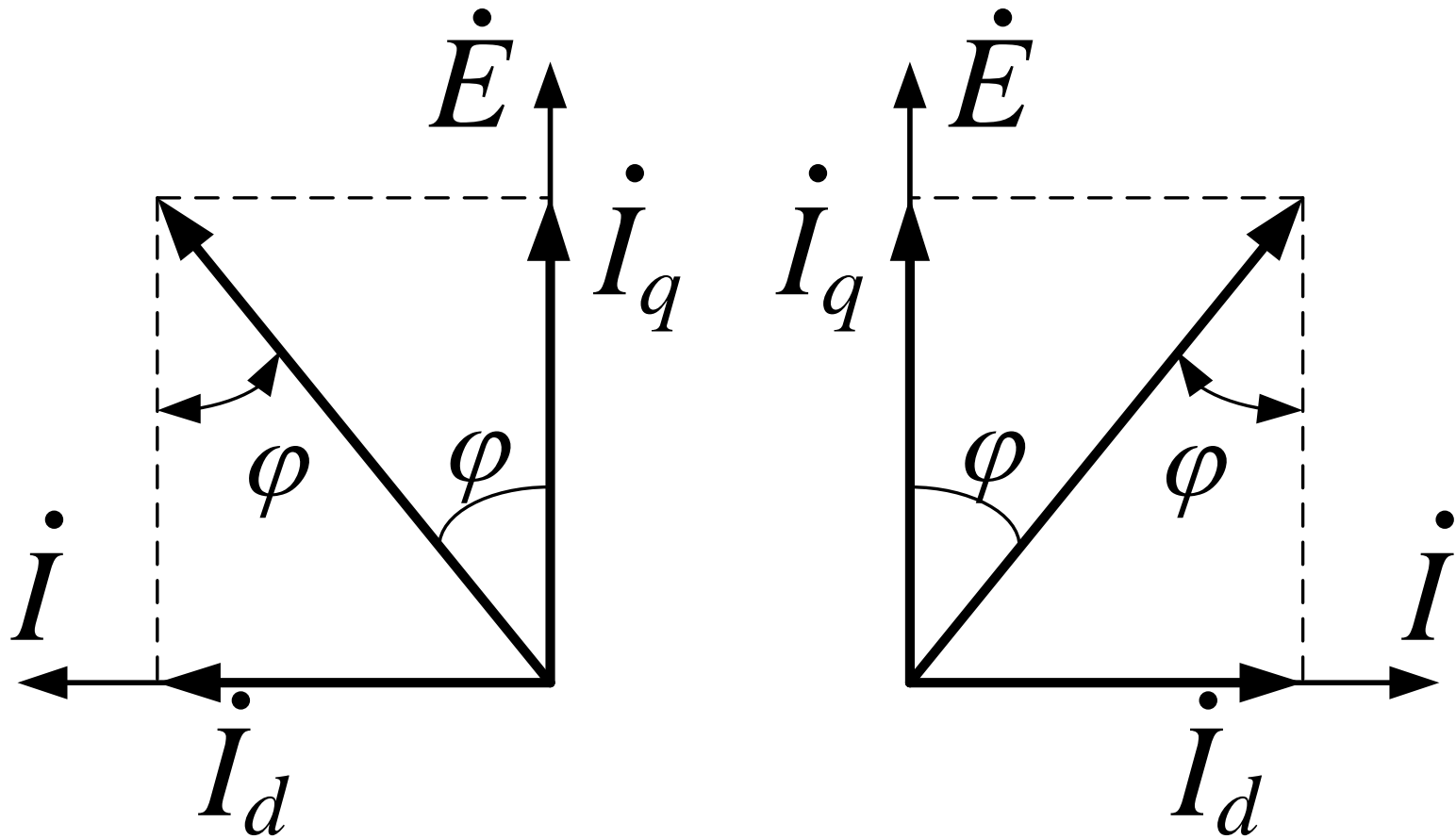

# Armature reaction

- The first harmonic magnitudes of direct-axis and quadrature-axis components of MMF of armature reaction are:

$$F_{ad} = \frac{m \cdot \sqrt{2}}{\pi} \cdot \frac{w_a \cdot k_{wa}}{p} \cdot I_d,$$

$$F_{aq} = \frac{m \cdot \sqrt{2}}{\pi} \cdot \frac{w_a \cdot k_{wa}}{p} \cdot I_q,$$

- where  $m$  – number of phases in armature winding,
- $w_a$  – number of turns in armature winding,
- $k_{wa}$  – winding factor of armature winding,
- $p$  – number of poles.

# Armature reaction

- As:

$$F_a = \frac{m \cdot \sqrt{2}}{\pi} \cdot \frac{w_a \cdot k_{wa}}{p} \cdot I,$$

- then:

$$F_{ad} = I \cdot \sin \varphi, \quad F_{aq} = I \cdot \cos \varphi.$$

The maximum value of MMF  $F_{ad}$  lies along the direct-axis of synchronous generator and  $F_{aq}$  lies in quadrature-axis of machine (curves 1), in the case of even air gap  $\delta = \delta_m$  MMFs  $F_{ad}$  and  $F_{aq}$  develop sinusoidal curves of flux density – curves 2. But in real salient pole synchronous generators air gap between stator and rotor is uneven  $\delta \neq \delta_m$ , thus flux density curves are as shown in fig. 18 (curves 3). Curve 4 is the first harmonics of armature reaction flux density with magnitudes  $B_{adm1}$  and  $B_{aqm1}$ .

# Armature reaction

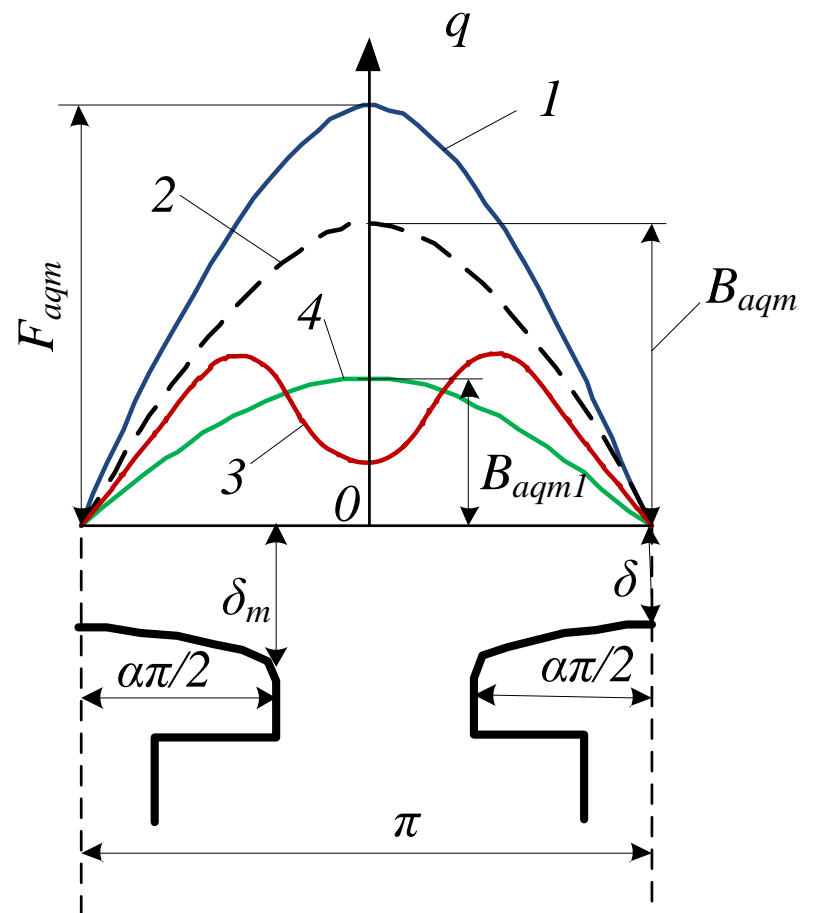
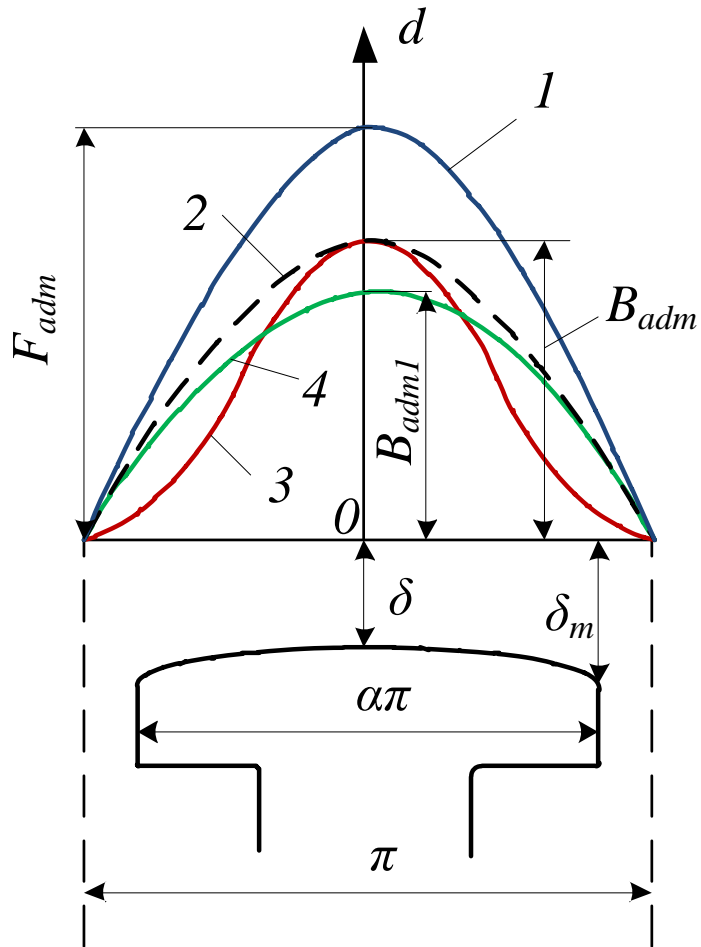



# SYNCHRONOUS MACHINES 3

---

# Open circuit characteristic of synchronous generator

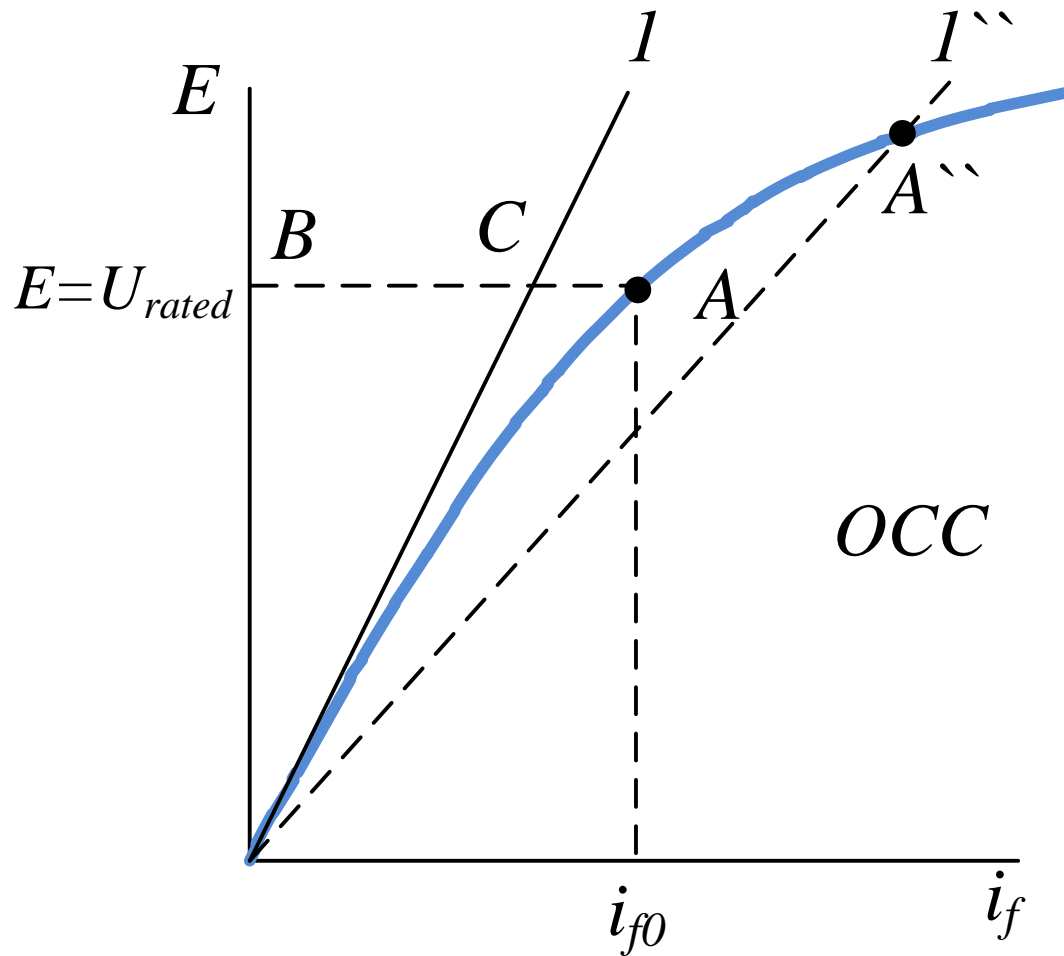

# Open circuit characteristic of synchronous generator

- Saturation ratio is the ratio between overall MMF of generator (A-B) to air gap MMF (B-C), so in most synchronous generators:

$$k_{\mu} = \frac{AB}{BC} = 1,1 \dots 1,2.$$

# The terminal or external characteristics of synchronous generators

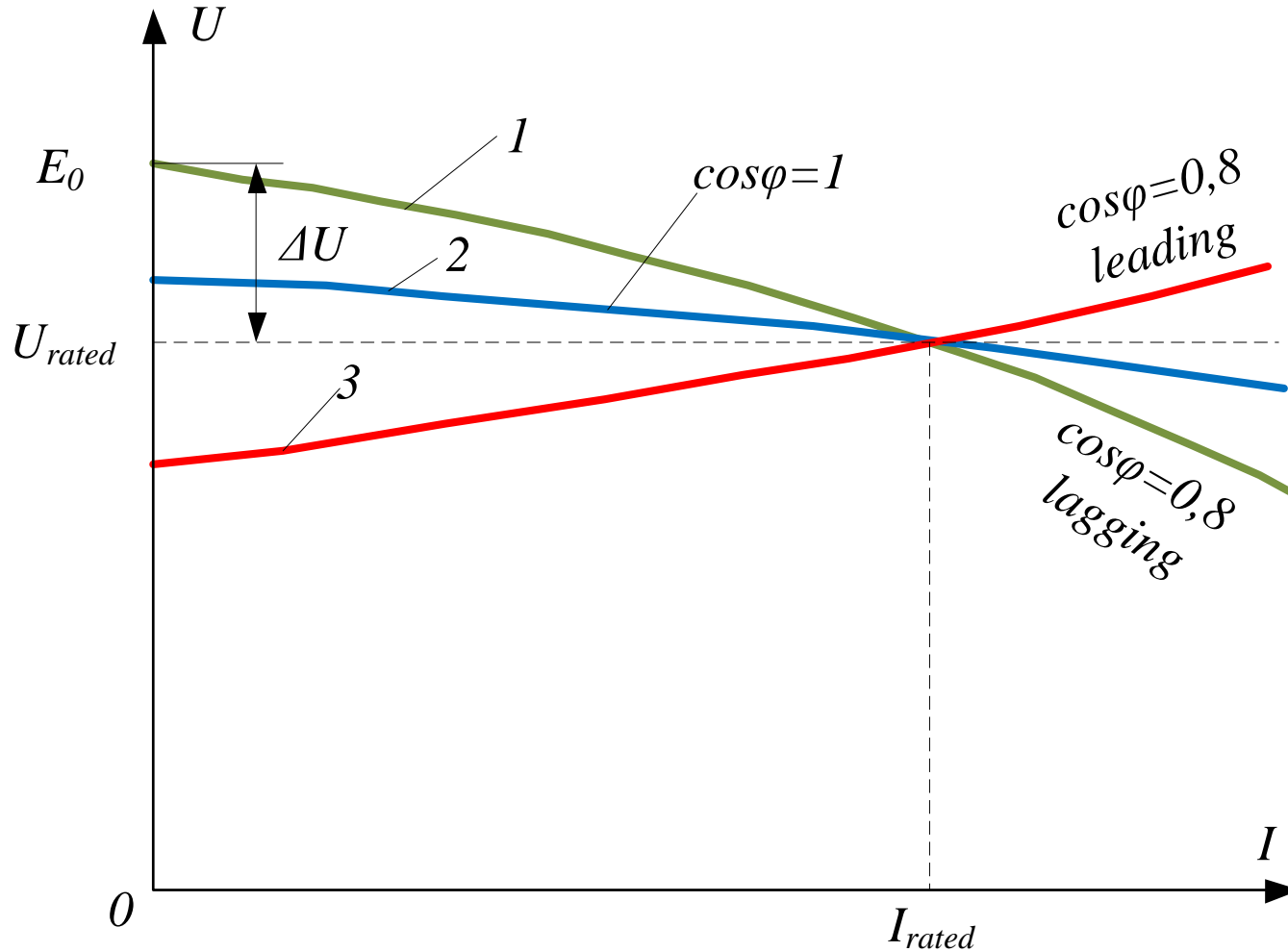

# The terminal or external characteristics of synchronous generators

- Voltage regulation is defined by:

$$\Delta U = \frac{E_0 - U_{rated}}{U_{rated}} \cdot 100\%.$$

- The most generators are lagging loaded so the voltage regulation will be 25...35 %.

# Control characteristic of synchronous generator

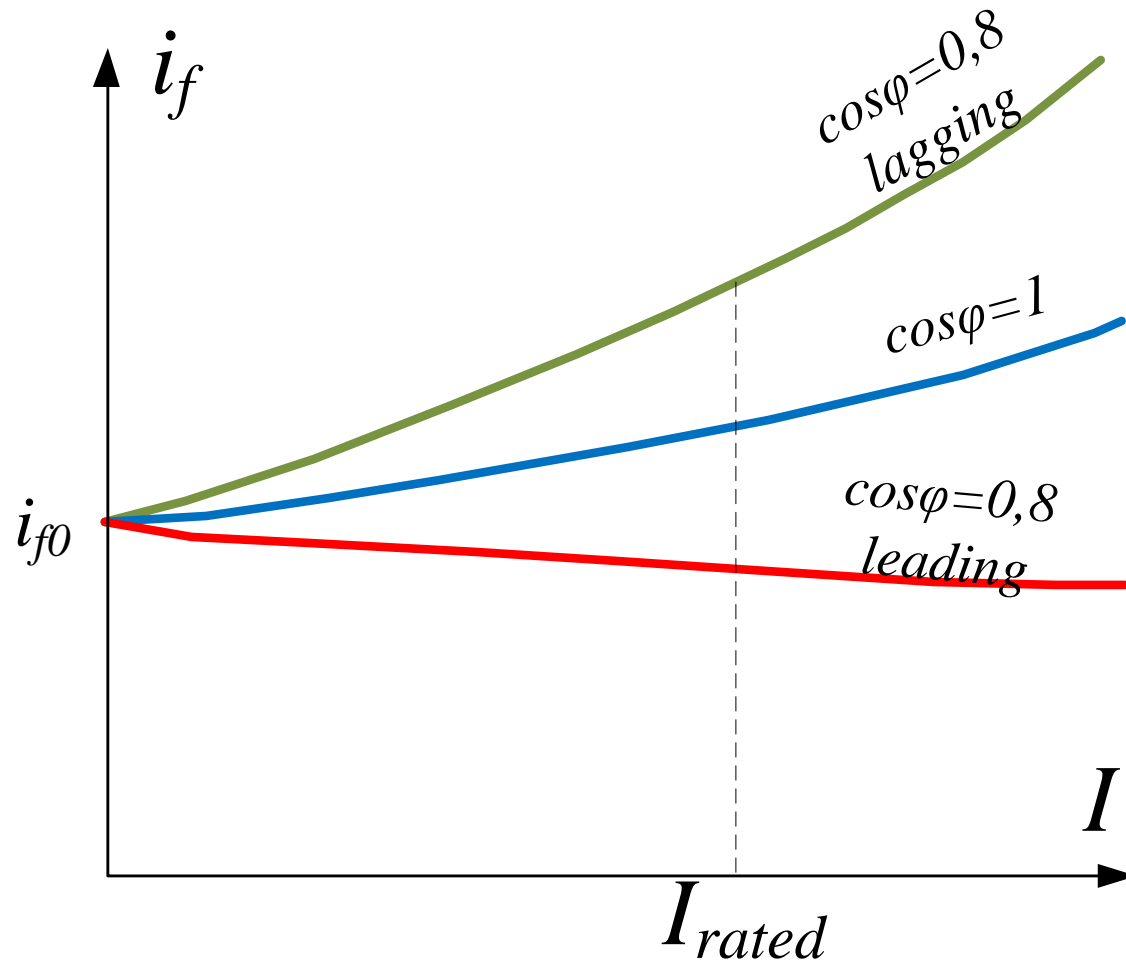

# Load characteristics of synchronous generator

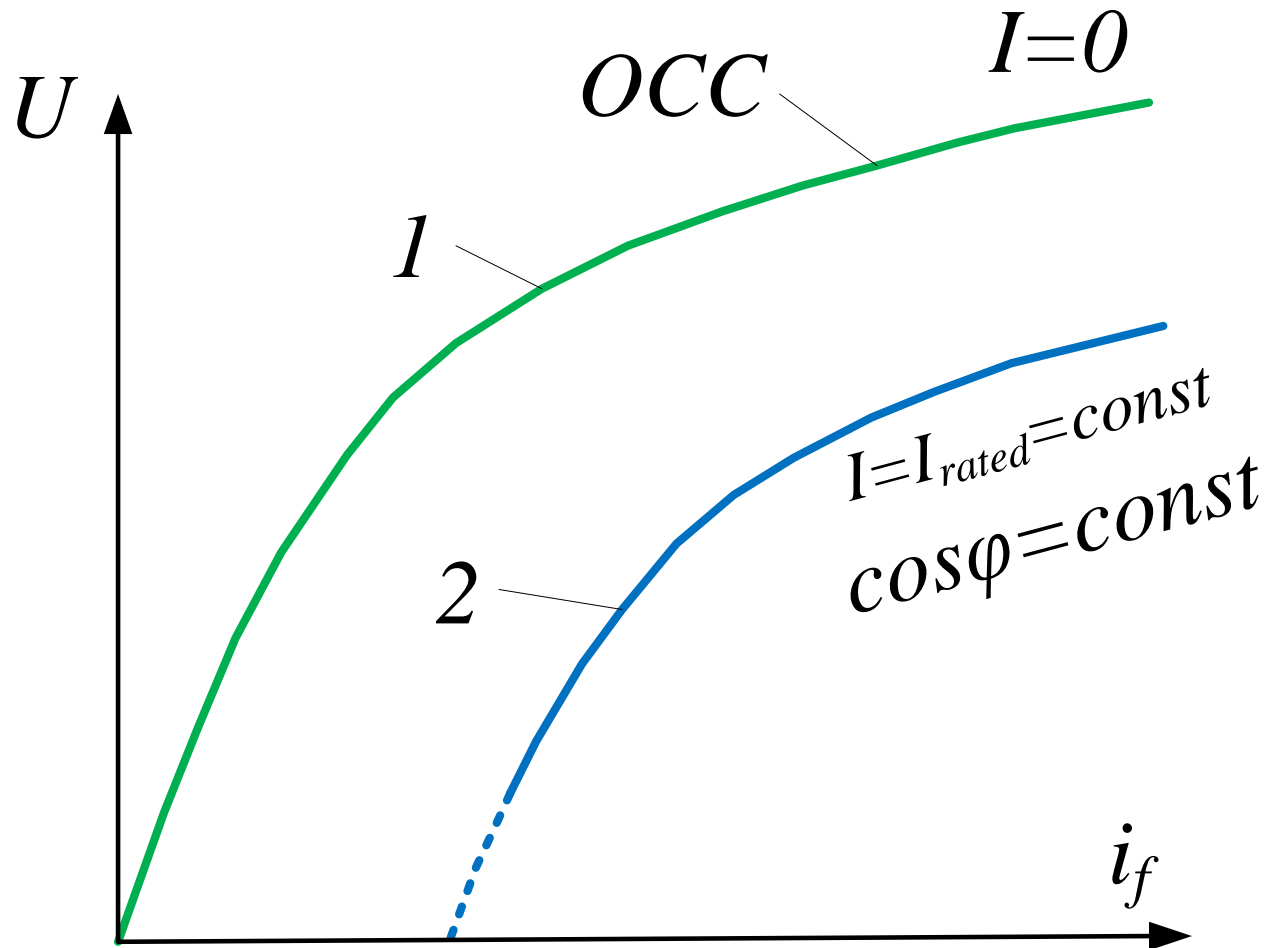

# Short circuit characteristics of synchronous generators

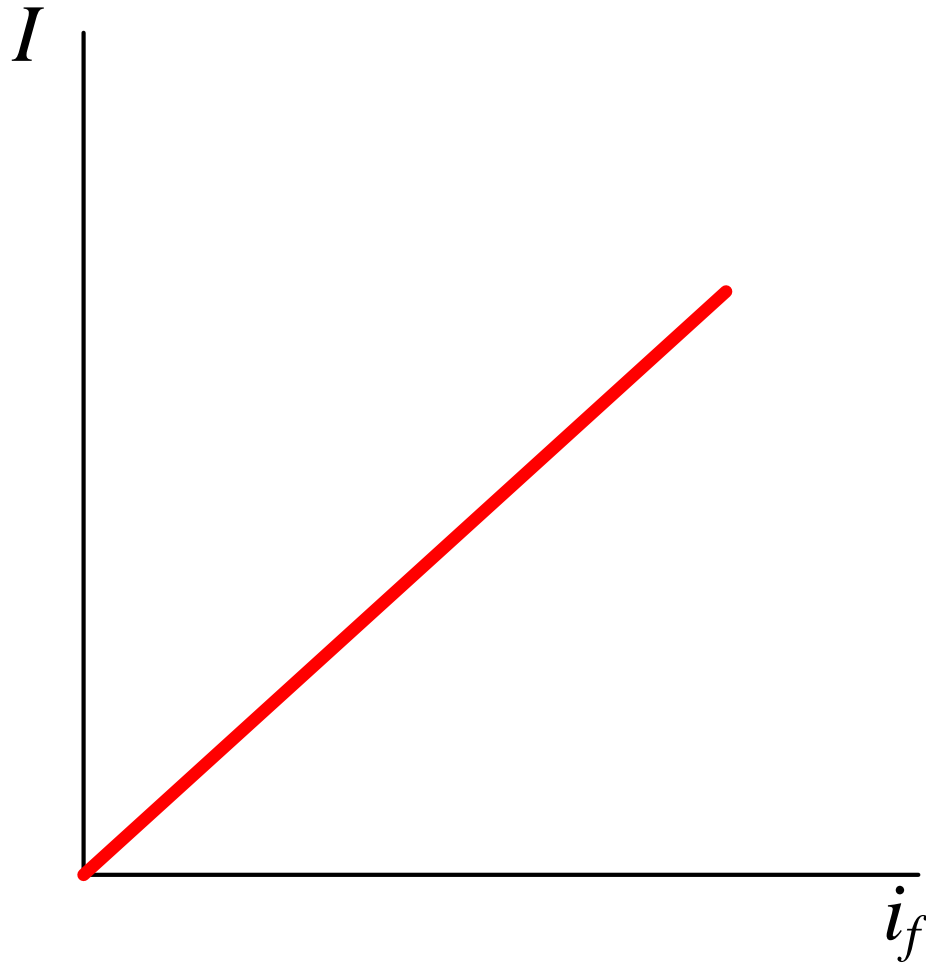



# Short circuit ratio

- Short circuit ratio or SCR is the measure of the generator stability characteristics. It is the ratio of field current  $I_{f0}$  required to produce rated armature voltage  $U_{\text{rated}}$  at open circuit to the field current  $I_{\text{fsc}}$  required to produce the rated armature current  $I_{\text{rated}}$  at short circuit:

$$\text{SCR} = \frac{I_{f0}}{I_{\text{fsc}}} = \frac{I_{\text{fsc0}}}{I_{\text{rated}}}$$

For salient pole generator  $\text{SCR} = 0,8 \dots 1,8$ ,

for cylindrical rotor generators  $\text{SCR} = 0,5 \dots 1,0$ .

SCR value is higher in generators with higher value of air gap between stator and rotor.

# Short circuit ratio

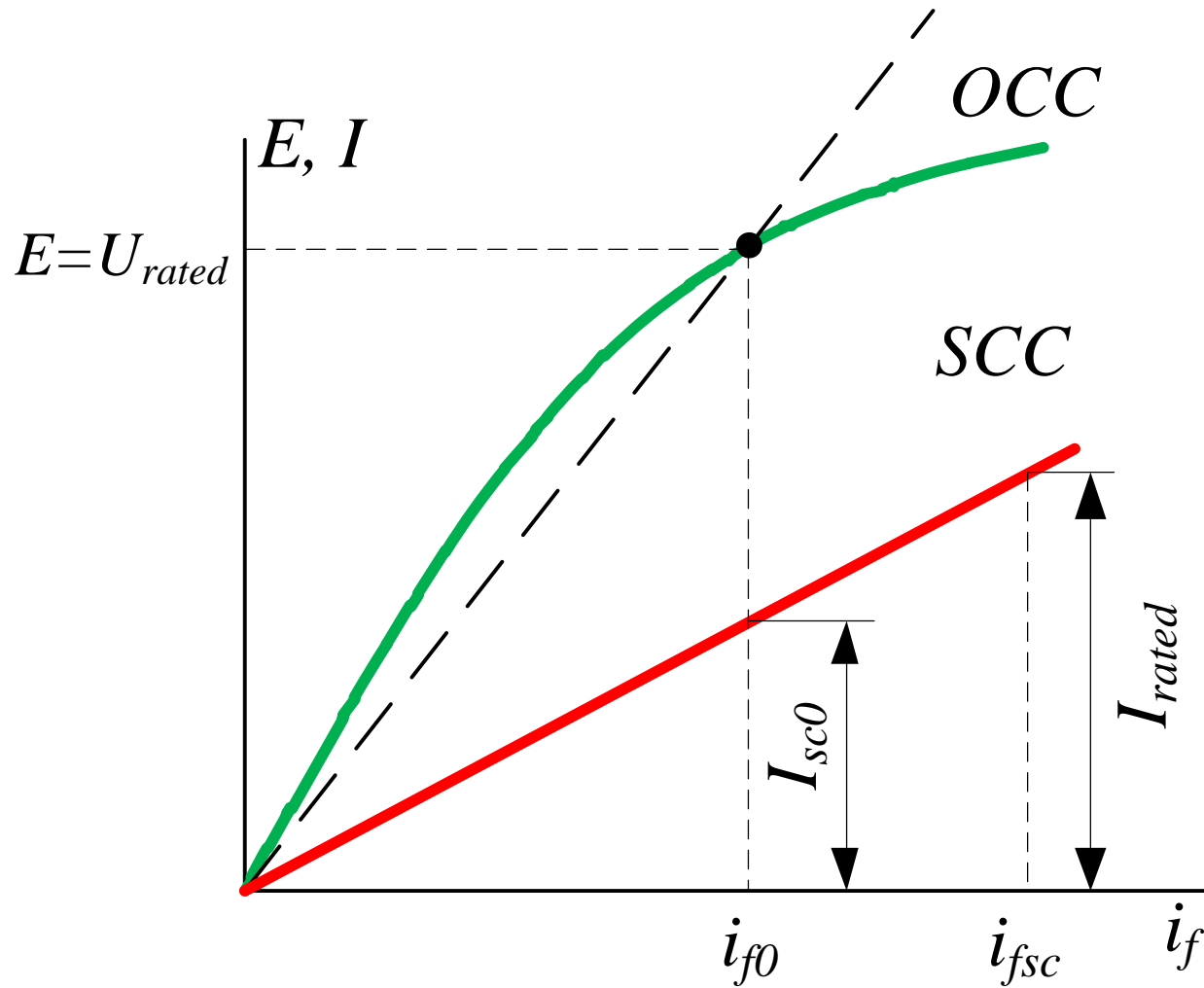

# Power angle characteristics of synchronous generator

- The per-phase armature-winding resistance of a synchronous generator is usually very small and can be neglected in comparison with its synchronous reactance. Thus power output of the generator is:

$$P = m \cdot U \cdot I \cdot \cos\varphi = m \cdot U \cdot (I_q \cdot \cos\delta + I_d \cdot \sin\delta),$$

- where  $m$  - number of phases,  $U$  – terminal voltage of generator,  $I$  – armature current,  $\cos\varphi$  – power factor, so the values of armature currents along direct and quadrature axis are:

$$I_d = \frac{E - U \cdot \cos\delta}{x_d}, \quad I_q = \frac{U \cdot \sin\delta}{x_q},$$

- therefore output power equation transforms to:

$$P = \frac{m \cdot E \cdot U}{x_d} \cdot \sin\delta + \frac{m \cdot U^2}{2} \left( \frac{1}{x_q} - \frac{1}{x_d} \right) \cdot \sin 2\delta.$$

# Power angle characteristics of synchronous generator

a)

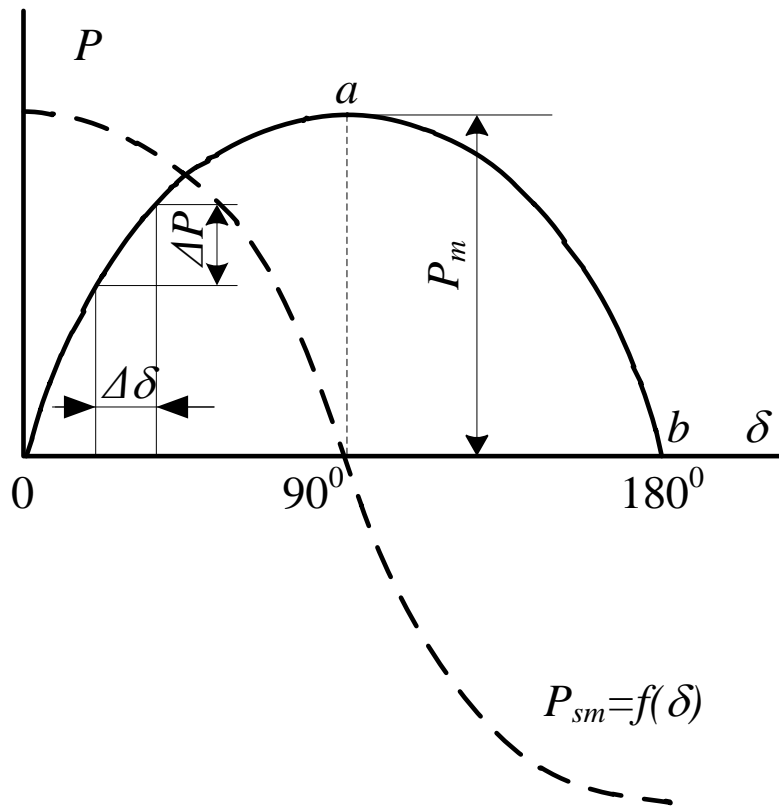

b)

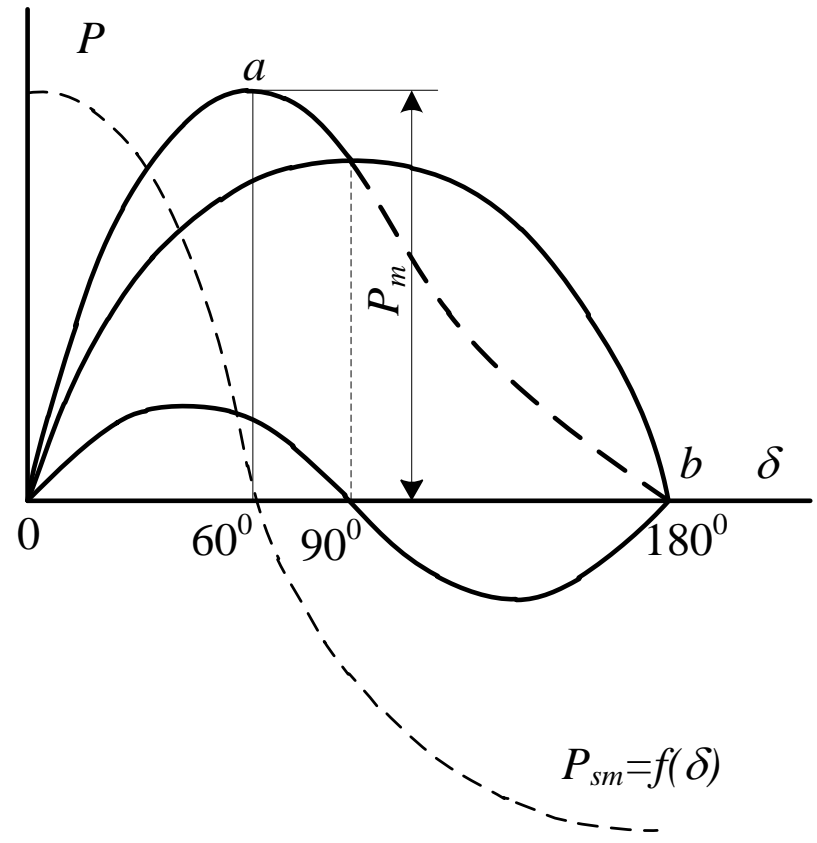

# SYNCHRONOUS MACHINES 4

---

# How does alternator works

Listen to the information provided in video fragment and fill the gaps.

# How does alternator works

- Alternators are the \_\_\_\_\_ of the power generation industry.
- It is capable to generate AC power at a \_\_\_\_\_.
- It is also called as \_\_\_\_\_ generator. Electricity is produced in alternators by \_\_\_\_\_.

# How does alternator works

- \_\_\_\_\_ and \_\_\_\_\_ coils are the two main parts of an alternator.
- This kind of rotor shown here is known as \_\_\_\_\_.
- Magnetic field produced around it would be a shown. The rotor is made to rotate by a \_\_\_\_\_.



# How does alternator works

- For this four pole system when the rotor turns \_\_\_\_\_, induced EMF takes \_\_\_\_\_.
- It is clear here that, frequency electricity produced is \_\_\_\_\_ with mechanical \_\_\_\_\_.
- Generally one end of these three coils are \_\_\_\_\_, and three phase electricity is drawn from the other ends.

# How does alternator works

- Pole core is used to \_\_\_\_\_ the magnetic flux, and they're made with fairly thick steel lamina.
- DC current is supplied from an \_\_\_\_\_ or from a small DC generator which is fitted on the same prime mover.
- Such alternators are called \_\_\_\_\_.
- If the \_\_\_\_\_ is below the desired limit, AVR increases the \_\_\_\_\_, thus the field strength.

# How does alternator works

- **Alternators are the workhorse of the power generation industry.** It is capable to generate AC power at a specified frequency.
- It is also called as synchronous generator. Electricity is produced in alternators by Electromagnetic Induction. To generate electricity in a coil, either the coil should rotate with respect to magnetic field or a magnetic field should rotate with respect to the coil. In the case of alternator the latter approach is used. Rotor and armature coils are the two main parts of an alternator. The rotor produces a rotating magnetic flux. Armature coils are stationary and rotating magnetic flux associated with the rotor induces electricity in the armature coils. This kind of rotor shown here is known as salient pole rotor. For gaining better insight of its working let's consider a rotor with just four poles 'Rotor coils are excited with a DC power source.
- Magnetic field produced around it would be as shown. The rotor is made to rotate by a prime mover. This makes the rotor flux also rotate along with it at the same speed. Such a revolving magnetic flux now intersects armature coils, which is fitted around the rotor. This will generate an alternating EMF across the winding. Here is a slowed down version of the rotor stator interaction. For this four pole system when the rotor turns half revolution, induced EMF takes one complete cycle. It can be easily established that, frequency of induced EMF, rotor speed and number of poles are connected through following relationship: It is clear here that, frequency electricity produced is synchronized with mechanical rotational speed. For producing 3 phase AC current, two more such armature coils which are in 120 degree phase difference with the first is put in the stator winding.
- Generally one end of these three coils are Star connected, and three phase electricity is drawn from the other ends.
- It is clear from this equation that, in order to produce 60-hertz electricity a 4-pole rotor should run at following RPM. Such huge rpm will induce a tremendous centrifugal force on poles of the rotor, and it may fail mechanically over the time. So salient pole rotors are generally having 10 to 20 poles, which demands lower RPM.
- Or salient pole rotors are used when the prime mover rotates at relatively lower RPM. Pole core is used to effectively transfer the magnetic flux, and they're made with fairly thick steel lamina. Such insulated lamina reduce energy loss due to eddy current formation. Armature winding of three-phase, 12 pole system is shown here. A stator core is used to enhance the magnetic flux transfer. DC current is supplied to rotor via a pair of slip rings.
- DC current is supplied from an external source or from a small DC generator which is fitted on the same prime mover.
- Such alternators are called self excited. With variation of load, Generator terminal output voltage will vary. It is desired to keep the terminal voltage in a specified limit
- An automatic voltage regulator helps in achieving this. Voltage regulation can be easily achieved by controlling the field current. If the terminal voltage is below the desired limit, AVR increases the field current, thus the field strength. This will result in an increase in terminal voltage. If terminal voltage is high, the reverse is done. We hope you had a nice introduction on the working of alternators.
- Thank you !

# How does alternator works

- Alternators are the **workhorse** of the power generation industry.
- It is capable to generate AC power at a **specified frequency**.
- It is also called as **synchronous** generator. Electricity is produced in alternators by **Electromagnetic Induction**.
- **Rotor** and **armature** coils are the two main parts of an alternator.
- This kind of rotor shown here is known as **salient pole rotor**.
- Magnetic field produced around it would be a shown. The rotor is made to rotate by a **prime mover**.
- For this four pole system when the rotor turns **half revolution**, induced EMF takes **one complete cycle**.
- It is clear here that, frequency electricity produced is **synchronized** with mechanical **rotational speed**.
- Generally one end of these three coils are **Star connected**, and three phase electricity is drawn from the other ends.
- Pole core is used to **effectively transfer** the magnetic flux, and they're made with fairly thick steel lamina. DC current is supplied from an **external source** or from a small DC generator which is fitted on the same prime mover.
- Such alternators are called **self excited**.
- If the **terminal voltage** is below the desired limit, AVR increases the **field current**, thus the field strength.

# SYNCHRONOUS MACHINES 5

---

# Parallel Operation of Synchronous Generators

- There are several major advantages to such operation:
  1. Several generators can supply a bigger load than one machine by itself.
  2. Having many generators increases the reliability of the power system, since the failure of anyone of them does not cause a total power loss to the load.
  3. Having many generators operating in parallel allows one or more of them to be removed for shutdown and preventive maintenance.
  4. If only one generator is used and it is not operating at near full load, then it will be relatively inefficient. With several smaller machines in parallel, it is possible to operate only a fraction of them. The ones that do operate are operating near full load and thus more efficiently.

# Parallel Operation of Synchronous Generators

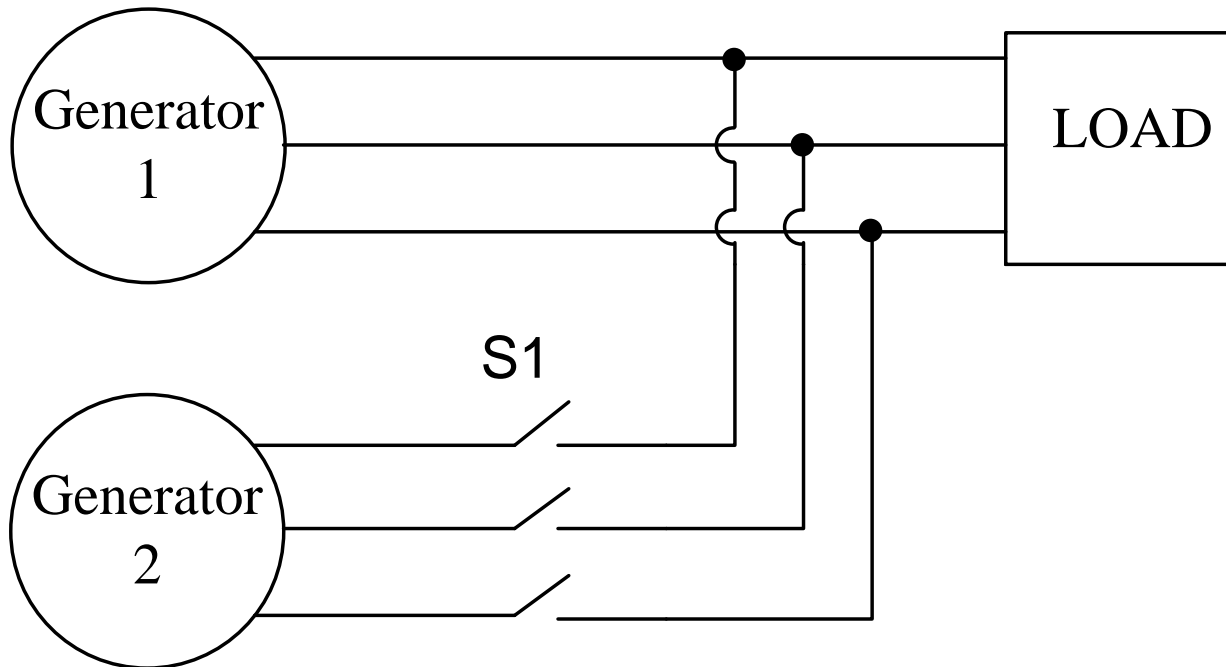

# Parallel Operation of Synchronous Generators

To achieve this match, the following paralleling conditions must be met:

- 1. The RMS line voltages of the two generators must be equal.
- 2. The two generators must have the same phase sequence.
- 3. The phase angles of the two a phases must be equal.
- 4. The frequency of the new generator, called the oncoming generator, must be slightly higher than the frequency of the running system.



# The U-curves of synchronous generators

- The power developed by the synchronous generator is:

$$P = \frac{m \cdot E \cdot U}{x_s} \cdot \sin\delta,$$

- where  $x_s$  – synchronous reactance of generator.

# The U-curves of synchronous generators

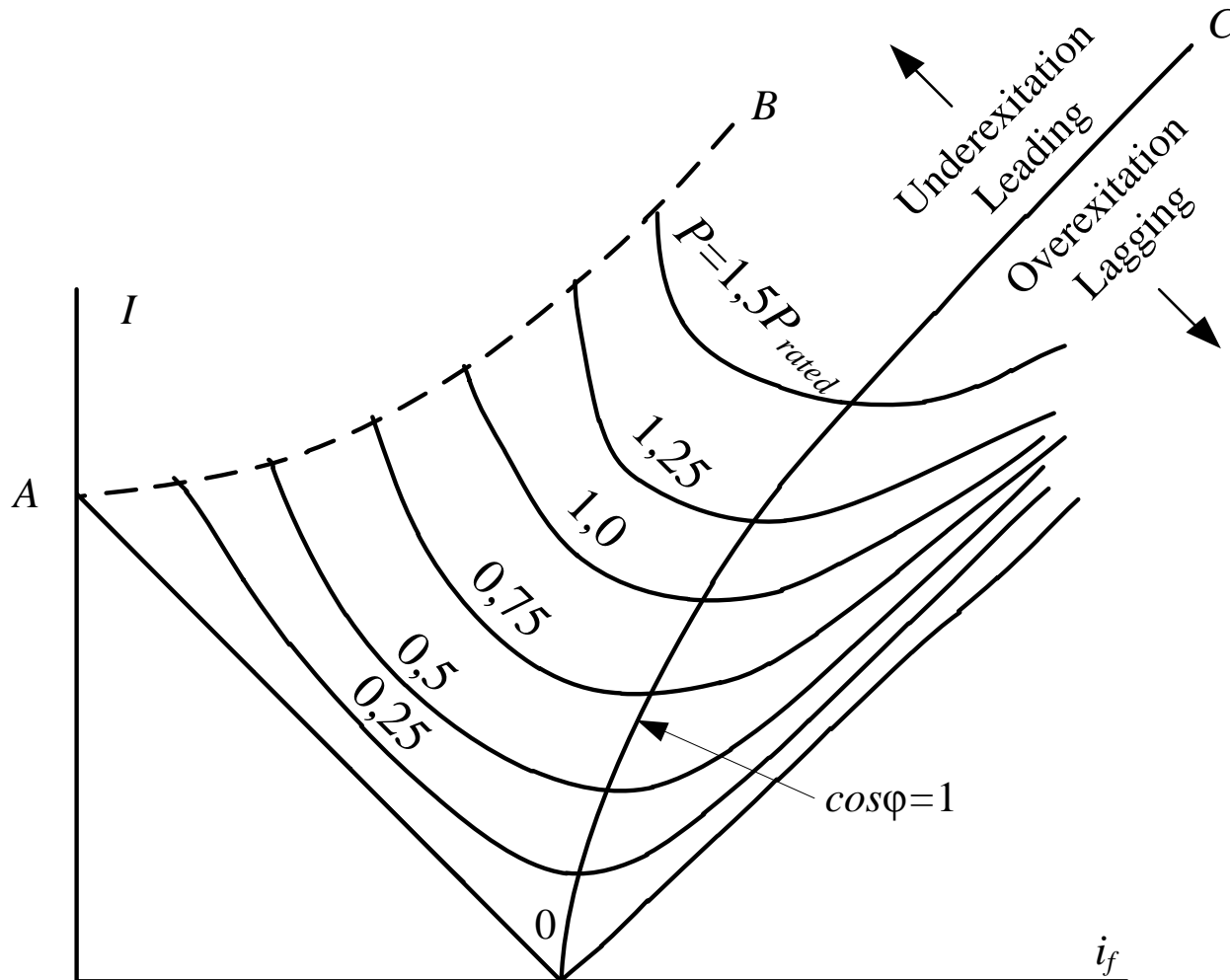

# SYNCHRONOUS MACHINES 6

---

# Synchronous Motor

- In general principal advantages of the synchronous motor are:
  1. The ease with which the power factor can be controlled.
  2. The speed is constant and independent of the load.

# Synchronous Motor

- The principal disadvantages are:
  - 1 . The cost per kilowatt is generally higher than that of an induction motor.
  - 2. A DC supply is necessary for the rotor excitation. This is usually provided by a small DC shunt generator carried on an extension of the shaft.
  - 3. Some arrangement must be provided for starting and synchronizing the motor.

# Methods of Starting of Synchronous Motor

- Basically there are three methods that are used to start a synchronous motor:
  1. To reduce the speed of the rotating magnetic field of the stator to a low enough value that the rotor can easily accelerate and lock in with it during one half-cycle of the rotating magnetic field's rotation.
  2. Synchronous motors are mechanically coupled with another motor.
  3. Damper winding.

# Methods of Starting of Synchronous Motor



- Synchronous motor coupled with induction motor

# Methods of Starting of Synchronous Motor

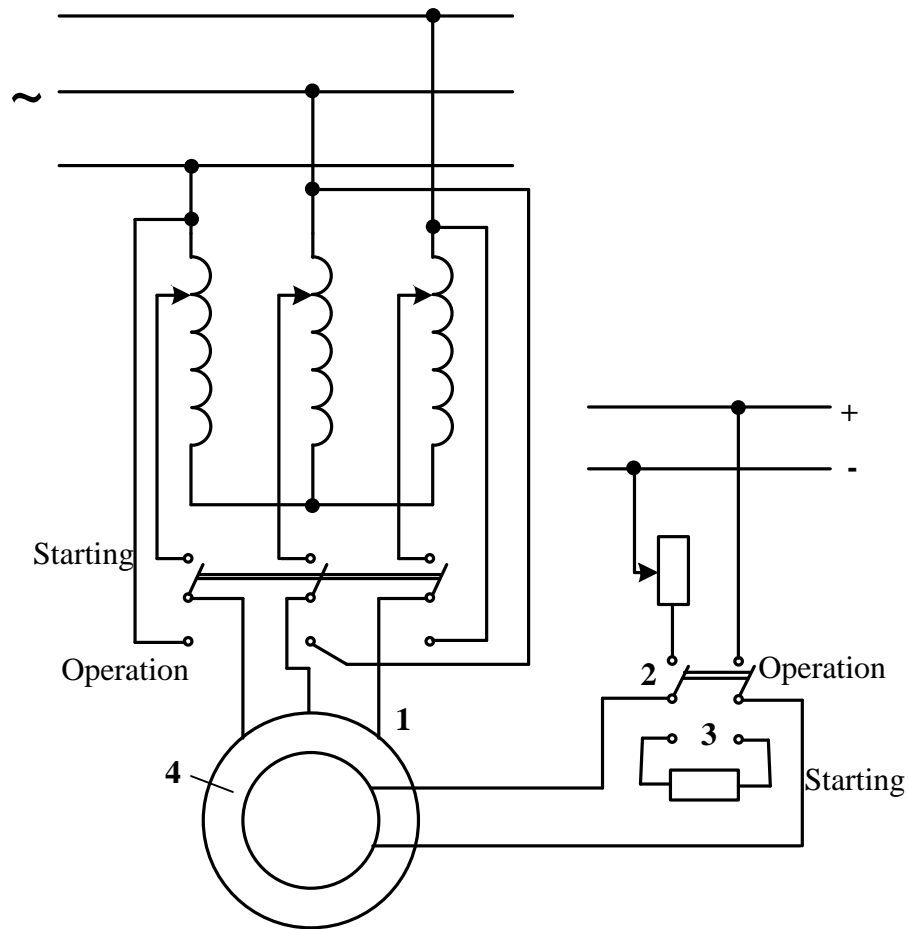

- Starting method with damper winding



# U Curves of Synchronous Motor

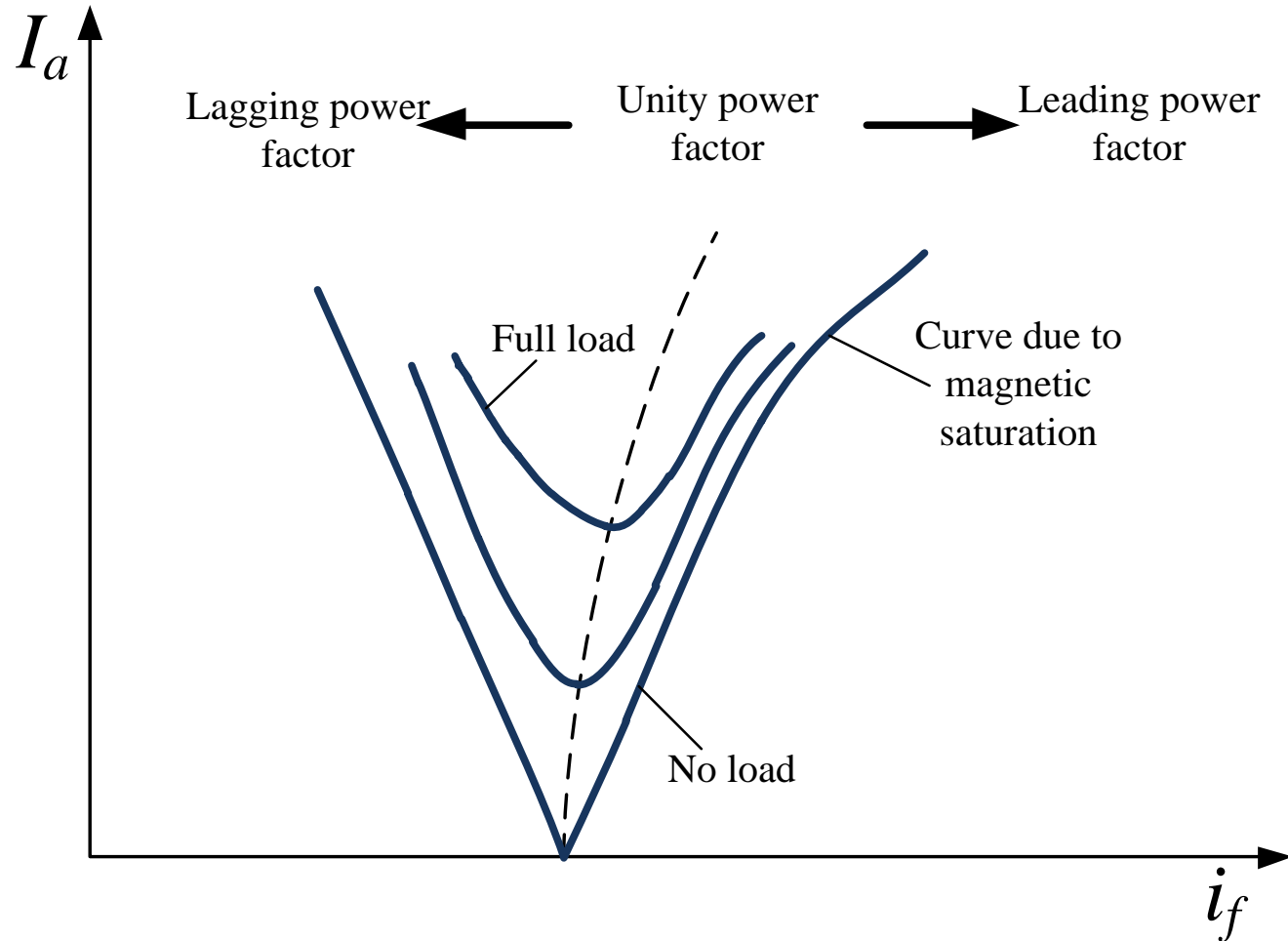

# Hunting in Synchronous Motor

- The word hunting is used because after sudden application of load the rotor has to search or hunt for its new equilibrium position. That phenomena is referred as hunting in synchronous motor. Now let us know what is the condition of equilibrium in synchronous motor.
- A steady state operation of synchronous motor is a condition of equilibrium in which the electromagnetic torque is equal and opposite to load torque. In steady state, rotor runs at synchronous speed there by maintaining constant value of torque angle ( $\delta$ ).

# Causes of Hunting in Synchronous Motor

- Sudden change in load.
- Sudden change in field current.
- A load containing harmonic torque.
- Fault in supply system.

# Effects of Hunting in Synchronous Motor

- It may lead to loss of synchronism.
- Produces mechanical stresses.
- Increases machine losses and cause temperature rise.
- Cause greater surges in electric current and power flow.

# Reduction of Hunting in Synchronous Motor

Two techniques should be used to reduce hunting. These are:

- **Use of Damper Winding.** It consists of low electrical resistance copper or aluminium brush embedded in slots of pole faces in salient pole machine. Damper winding damps out hunting by producing torque opposite to slip of rotor.
- **Use of Flywheels.** The prime mover is provided with a large and heavy flywheel. This increases the inertia of prime mover and helps in maintaining the rotor speed constant.

# Reduction of Hunting by Damper Winding

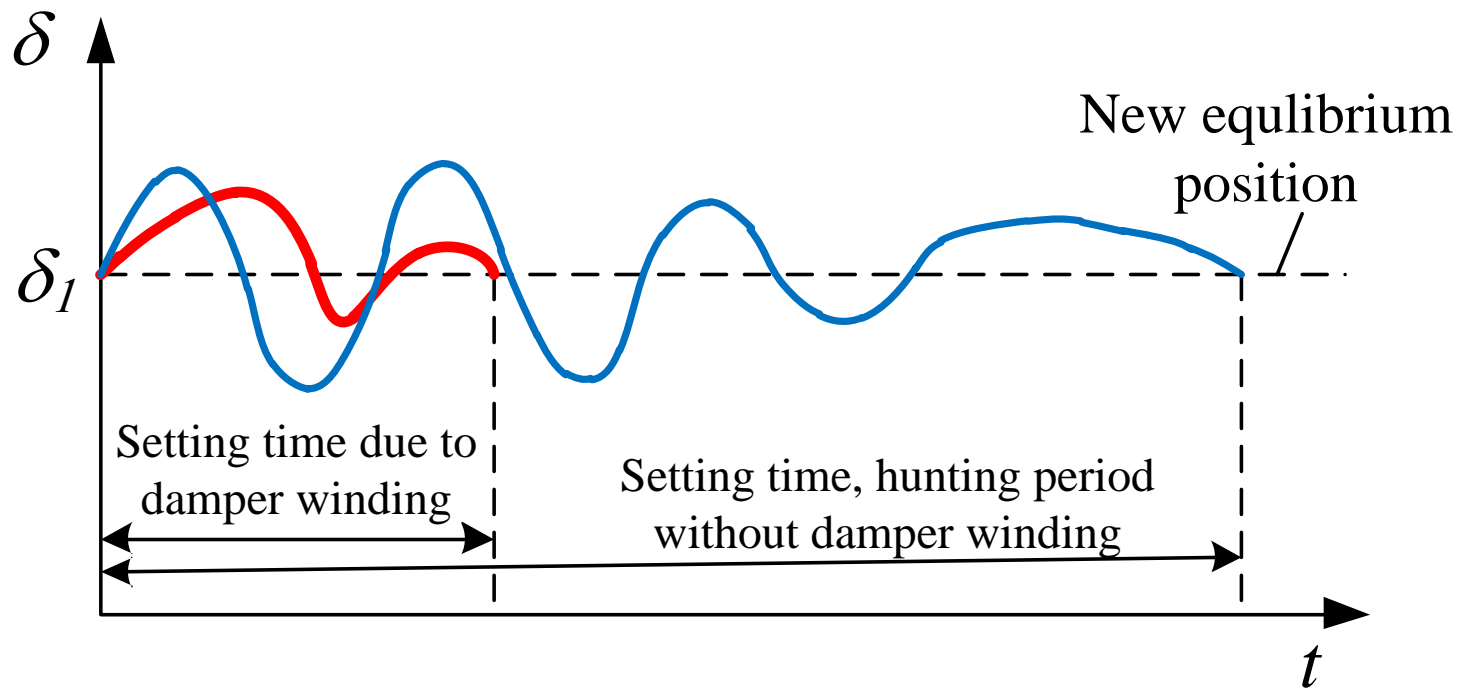

# Operating performance curves of synchronous motors

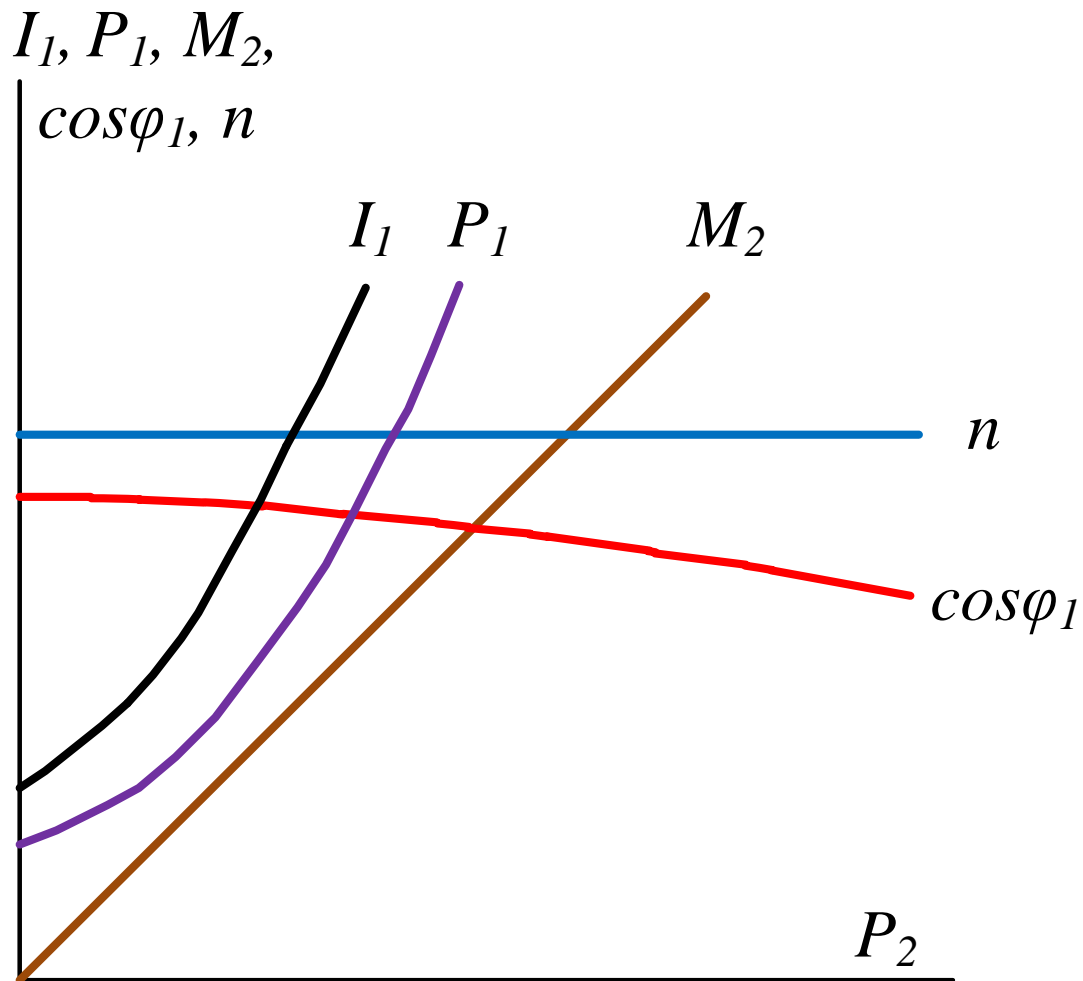

# SYNCHRONOUS MACHINES 7

---



# TESTING OF THREE PHASE SYNCHRONOUS GENERATOR

- **Purpose of laboratory session**
- The purpose of the given work is to study construction and working principle of the synchronous generator, to carry out experiments and obtain magnetization curve, external and short circuit characteristics of the synchronous generator.

# Operating program

- To examine the working principle of the synchronous generator and to classify the construction of alternative current machines.
- To define the laboratory unit.
- To start the synchronous generator.
- To make experiment of open circuit of synchronous generator and obtain magnetization curve.
- To provide load test of synchronous generator and to build external characteristics of synchronous generator.
- To calculate voltage regulation of synchronous generator.
- To provide short circuit test of synchronous generator and to build short circuit characteristics of synchronous generator.
- To analyze the generator characteristics and make conclusions.

# Self-instruction

# Self-instruction

- Synchronous generator – *(give the definition)* \_\_\_\_\_

---

---

---

---

---

---

---

---

- The synchronous generator consists of following main components *(write title, purpose and material)*:

- 1. \_\_\_\_\_
- 2. \_\_\_\_\_
- 3. \_\_\_\_\_
- 4. \_\_\_\_\_



# Self-instruction

- Draw the salient pole and non-salient pole rotors construction and make all necessary notes.

# Self-instruction

- The voltage equations of salient pole synchronous generator:

- $\underline{V}_d = \underline{E}_d - \omega \underline{\lambda}_d - R_a \underline{i}_d$

- $\underline{V}_q = \underline{E}_q - \omega \underline{\lambda}_q - R_a \underline{i}_q$

- where  $\underline{E}_d = -\omega \underline{\lambda}_d$

- $\underline{E}_q = \omega \underline{\lambda}_q$

- $\underline{\lambda}_d = L_d \underline{i}_d + \underline{\lambda}_{fd}$

- $\underline{\lambda}_q = L_q \underline{i}_q$

- $\underline{\lambda}_{fd} = L_{fd} \underline{i}_{fd}$

# Self-instruction

- The voltage equations of non-salient pole synchronous generator:

- $$V_t = E_a - I_a R_a - I_q X_q \sin \delta - I_d X_d \cos \delta$$

- $$0 = E_a \sin \delta - I_q X_q \cos \delta - I_d X_d \sin \delta$$

- where 
$$E_a = K \omega_f \Phi$$

- $$I_d = I_a \cos \delta$$

- $$I_q = I_a \sin \delta$$

- $$X_d = \omega L_d$$

- $$X_q = \omega L_q$$



# Self-instruction

- Non-salient pole synchronous generator field of application:

- ---

---

---

---

---

---

- Salient pole synchronous generator field of application:

- ---

---

---

---

---

---

# Self-instruction

- Armature reaction in synchronous generator is:

- ---

---

---

---

---

- ---

---

---

---

---

- Armature reaction of alternator at unity power factor

- ---

---

- ---

---

---

---

---

# Self-instruction

- Armature reaction of alternator at lagging zero power factor

- ---

---

- ---

---

---

---

---

- Armature reaction of alternator at leading zero power factor

- ---

---

- ---

---

---

---

---

# Self-instruction

- The open circuit mode of synchronous generator is \_  
\_\_\_\_\_
- To open circuit mode losses could be included following  
\_\_\_\_\_

# Self-instruction

- The short circuit test of synchronous generator is \_\_\_\_\_  
\_\_\_\_\_
- To short circuit losses could be included following \_\_\_\_\_  
\_\_\_\_\_

# Self-instruction

- The load test of synchronous generator is \_\_\_\_\_  
\_\_\_\_\_
- Conditions for parallel operation of synchronous generators:
  - \_\_\_\_\_
- Starting methods of synchronous motors:
  - \_\_\_\_\_